



National Technical University of Athens
School of Electrical and Computer Engineering
Electric Energy Systems Lab

Contribution of doubly fed wind generators on power systems oscillation damping

Yorgos Tsourakis

Contents



1. Model of wind farm with DFAGs (aka DFIG) for stability studies: WECC “generic DFAG model”, based on manufacturer data, implemented in PSS/E
2. Modes introduced by DFAGs (OMIB system)
3. Effect of DFAGs on small-signal stability of a small interconnected system
4. Wind PSS
5. Hellenic system case study

Generator/Converter 'algebraic' model

⌘ Active and reactive current source representation

$$P = VI_P$$

$$Q = V \frac{E_q'' - V}{X_{eq}}$$

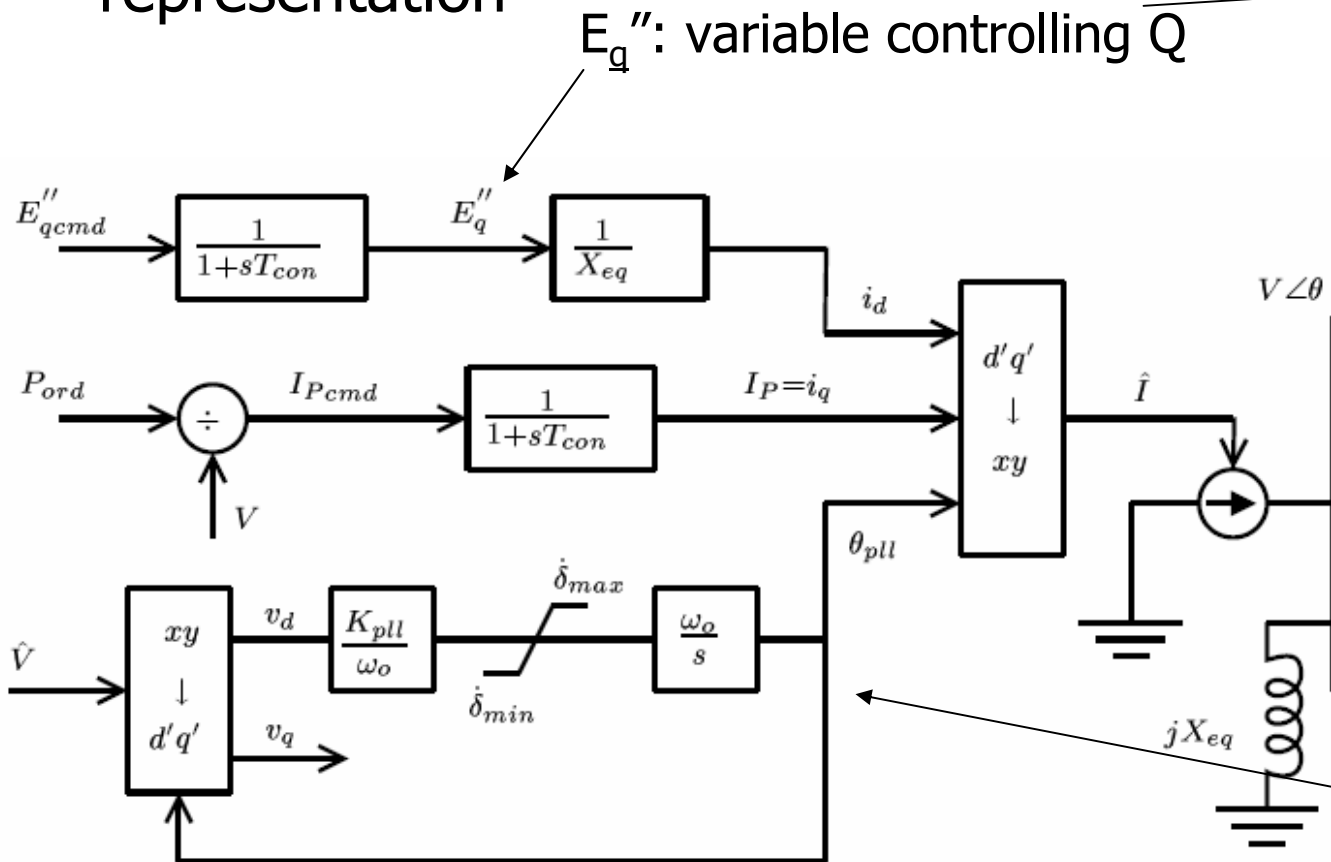

Phase Locked Loop

Two-mass model

⌘ Shaft torsional mode of oscillation

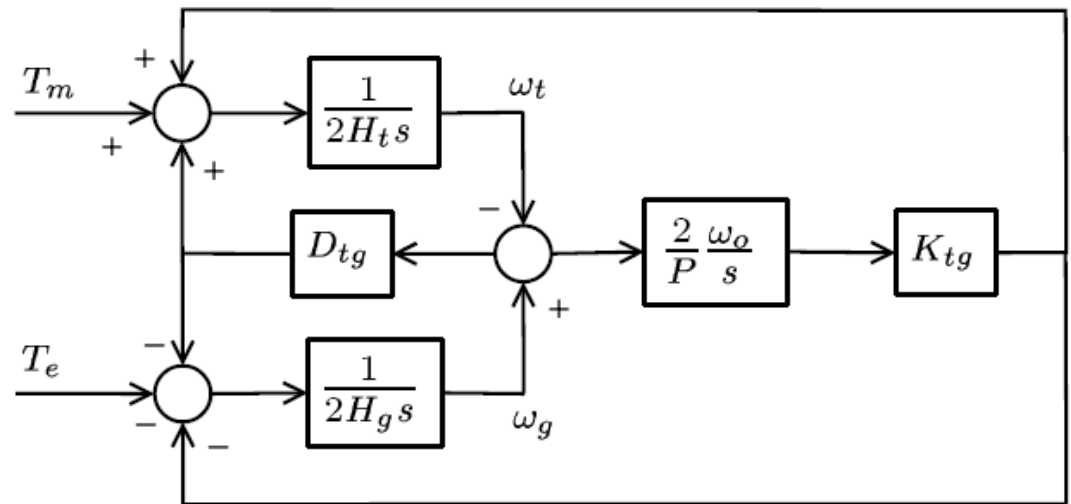

Active power control

⌘ Speed control

⌘ Pitch control / pitch compensation

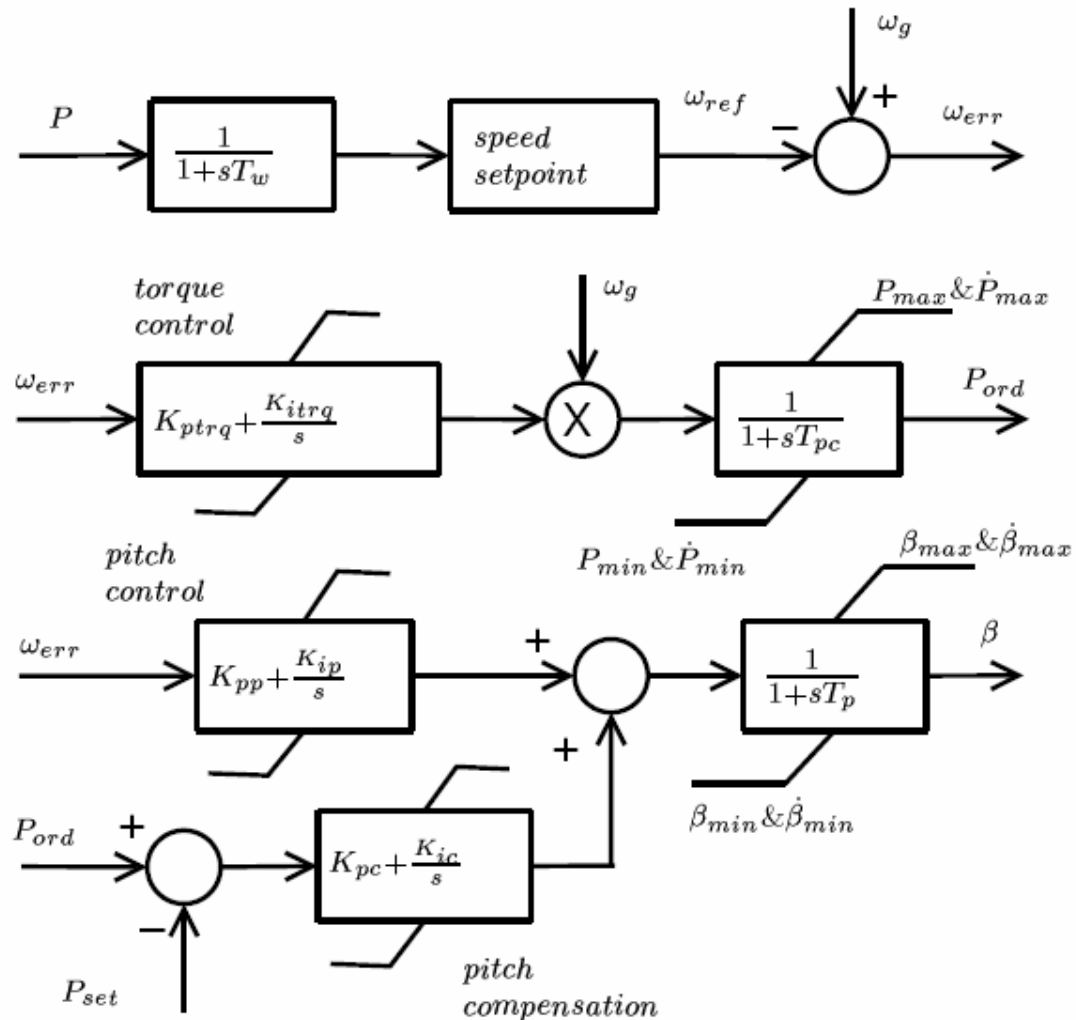

Reactive power control

Two control modes:

Power factor (PF) control

Voltage Control (VC)

Point of common coupling

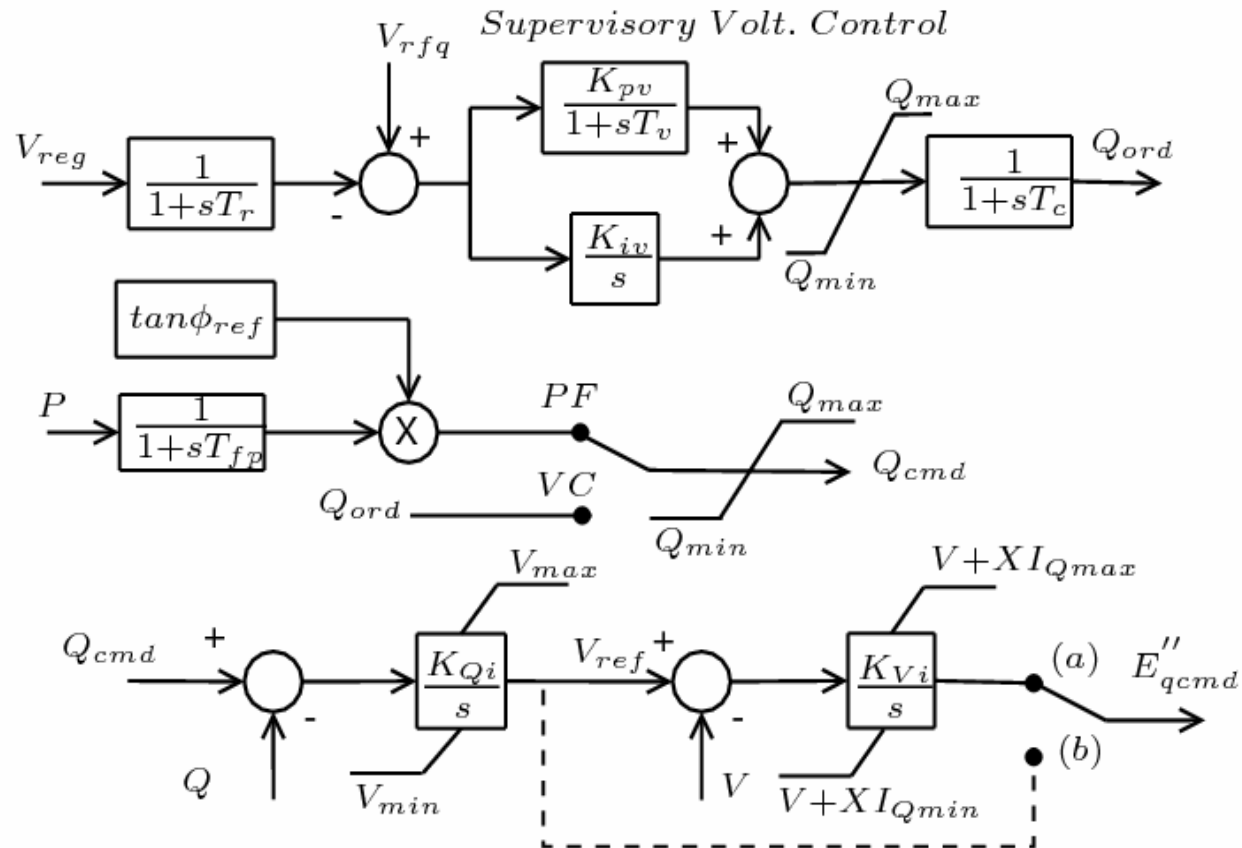

Terminal voltage control (TVC)

VAR control oscillation mode

Modes introduced by DFAG

- ⌘ Model implemented in Matlab/Simulink
- ⌘ Fault response and eigenvalues (3-bus system)
- ⌘ Model validation by comparing with PSS/E program
- ⌘ Examined case: PF control with TVC

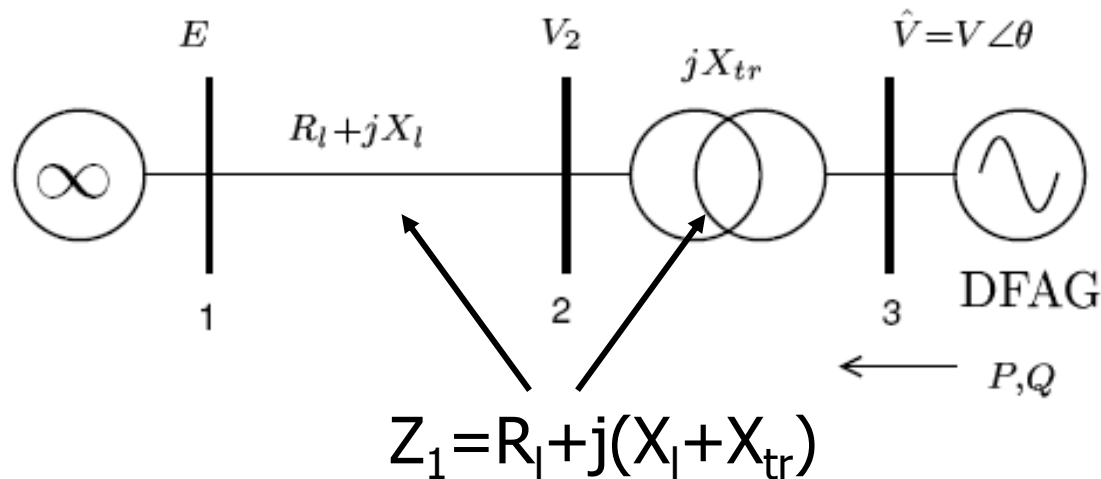

OMIB system: fault response

⌘ DFAG terminal voltage

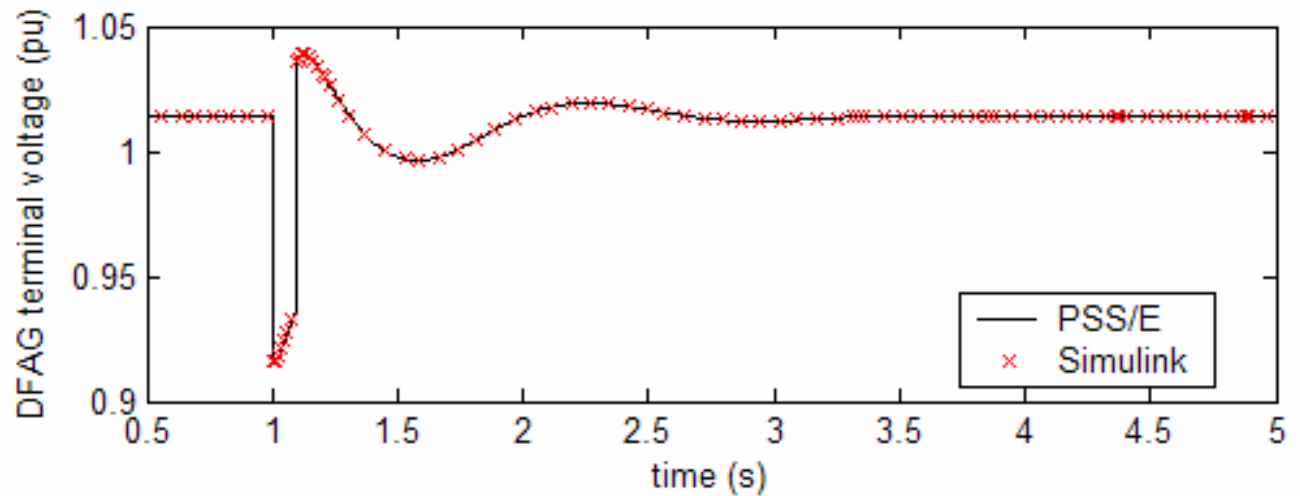

⌘ DFAG rotor speed

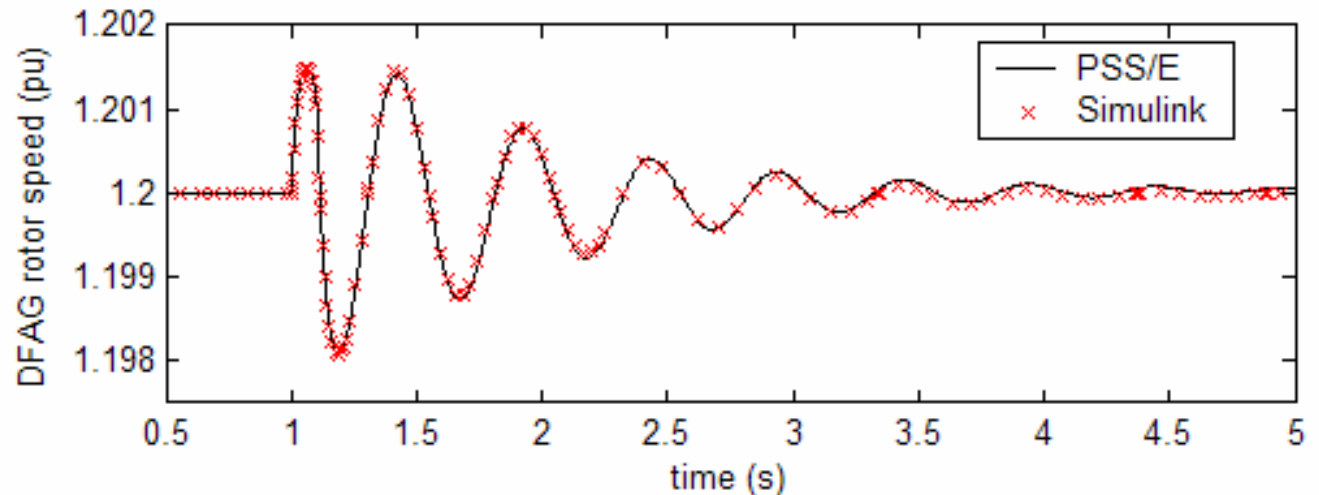

OMIB system: eigenvalues

PSS/E		Simulink		Response mode
Real	Imag.	Real	Imag.	
-1.124	12.50	-1.127	12.50	Shaft
-1.696	4.64	-1.690	4.64	VAR controller
-0.165	0.23	-0.189	0.19	Speed control
-51.084		-51.084		I_p time constant
-47.348		-47.356		E'_q time constant
-27.966		-27.976		PLL
-17.219		-17.224		P_{ord} actuator
-0.200		-0.200		T_w filter
-3.322	0.01	-3.324		Pitch delay & P filter, T_p
-0.035				Pitch compensation
0.000				Pitch control

Small-signal stability of interconnected power system with high DFAG-based wind power production

- ⌘ System with one (equivalent) local synchronous generator in Simulink ($P_{gen} = 378$ MW)
- ⌘ Gradual increase of wind power together with equal increase of system load \rightarrow SG operating point remains constant

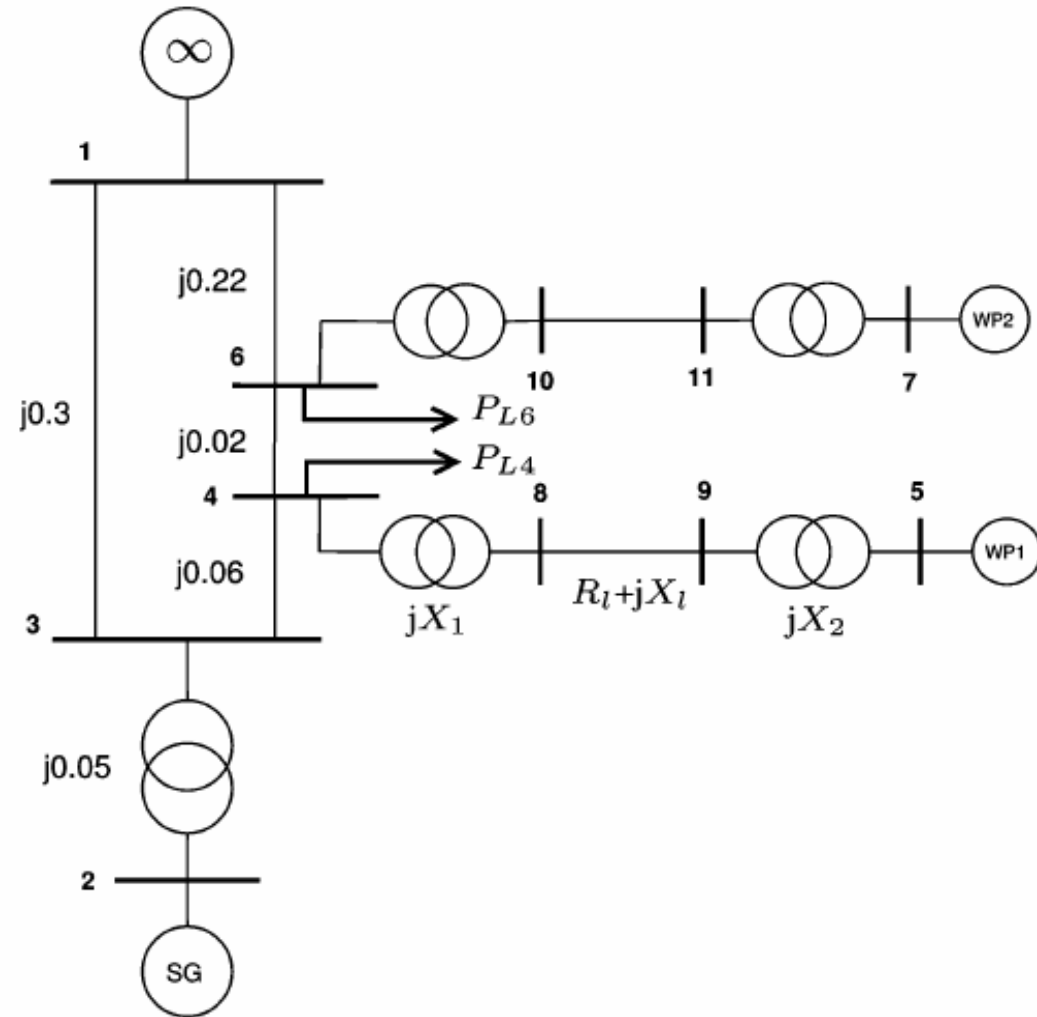

Locus of electromechanical eigenvalues with wind power production increase

- ⌘ 0 – 380 MW of wind power
- ⌘ 4 DFAG model configurations:
 - ⊞ With or without terminal voltage control (TVC)
 - ⊞ Power factor (PF) control or voltage control (VC)
- ⌘ Base case: lightly damped ($\zeta=1\%$)

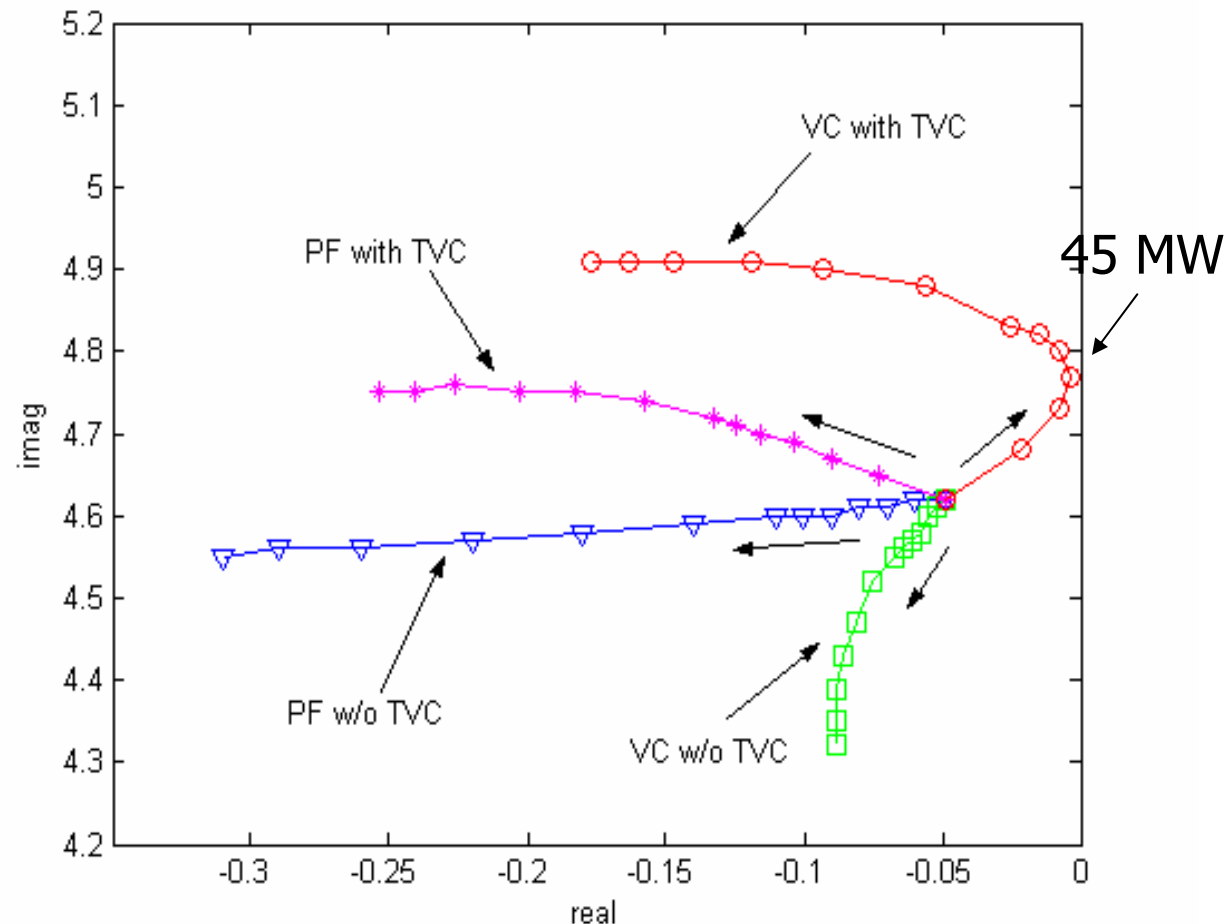

Dominant eigenvalues locus as wind power increases. DFAG in voltage control mode with TVC

⌘ VAR control
oscillation mode
frequency close to
electromechanical
one → adverse
interaction is
possible

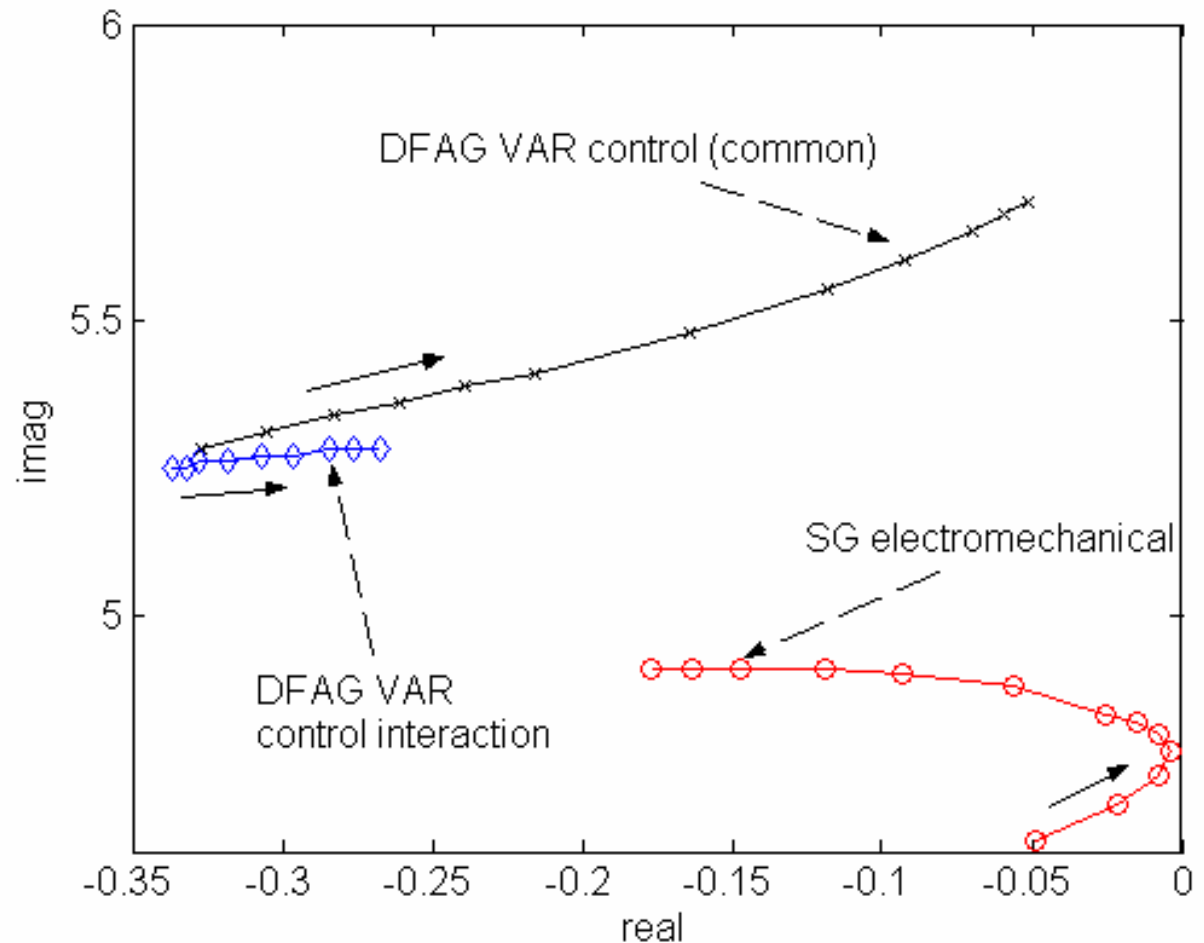

Tuning of VAR control mode

- ⌘ Decrease K_{Qi} → Avoid interaction
- ⌘ Damping almost unchanged for 45 MW of wind
- ⌘ VAR control mode:
 - $-0.283 + j*5.34$,
 $\zeta = 0.053$
($K_{Qi} = 0.5$)
 - $-1.796 + j*2.09$,
 $\zeta = 0.653$
($K_{Qi} = 0.1$)

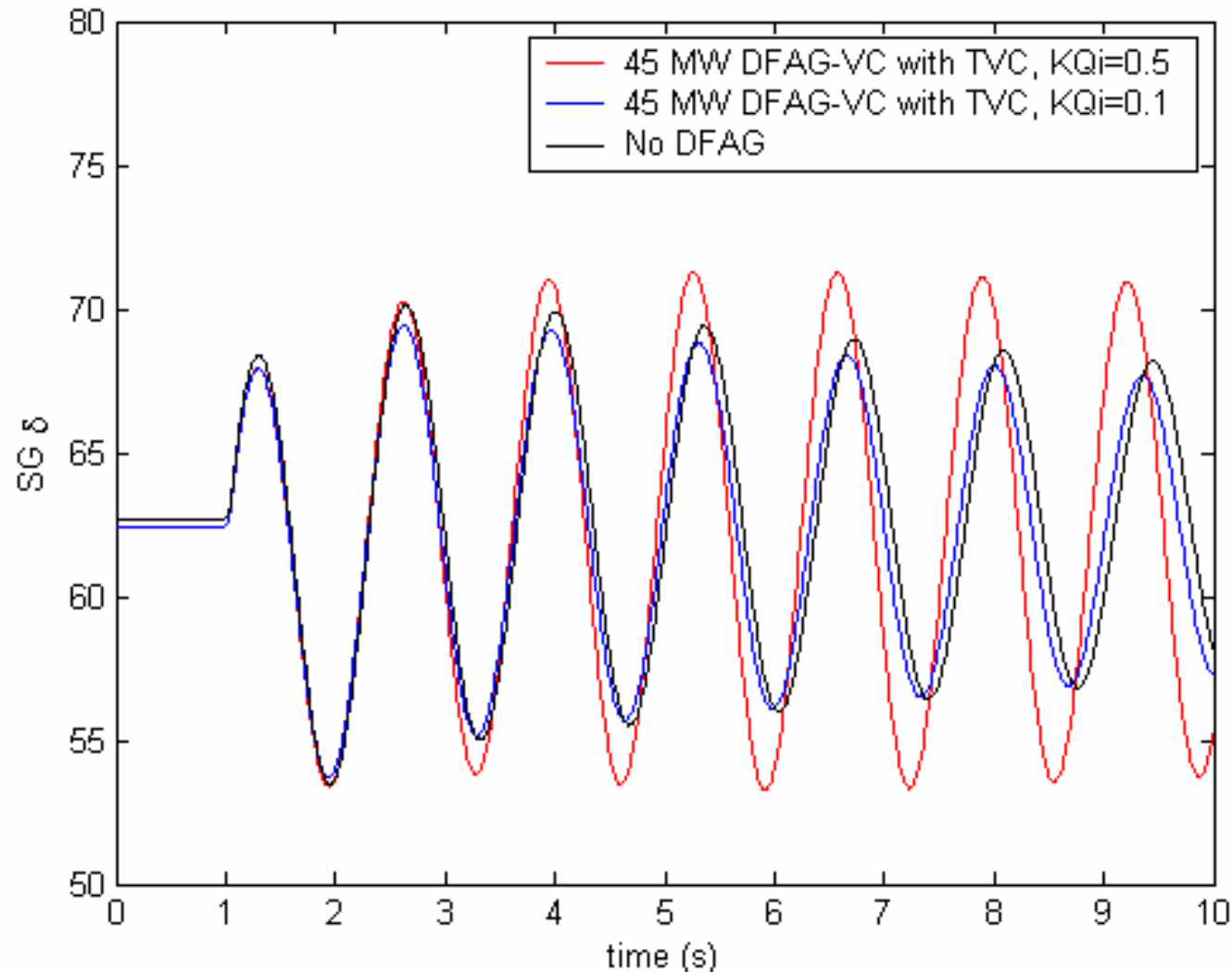

Wind PSS (1)

⌘ Auxiliary signal proportional to frequency deviation, subtracted from Pref

⌘ $\Delta f > 0 \rightarrow$
 P_{DFAG} decrease \rightarrow
 P_{SG} increase \rightarrow
 SG rotor decelerates

⌘ Wash-out filter

⌘ Also adds inertia

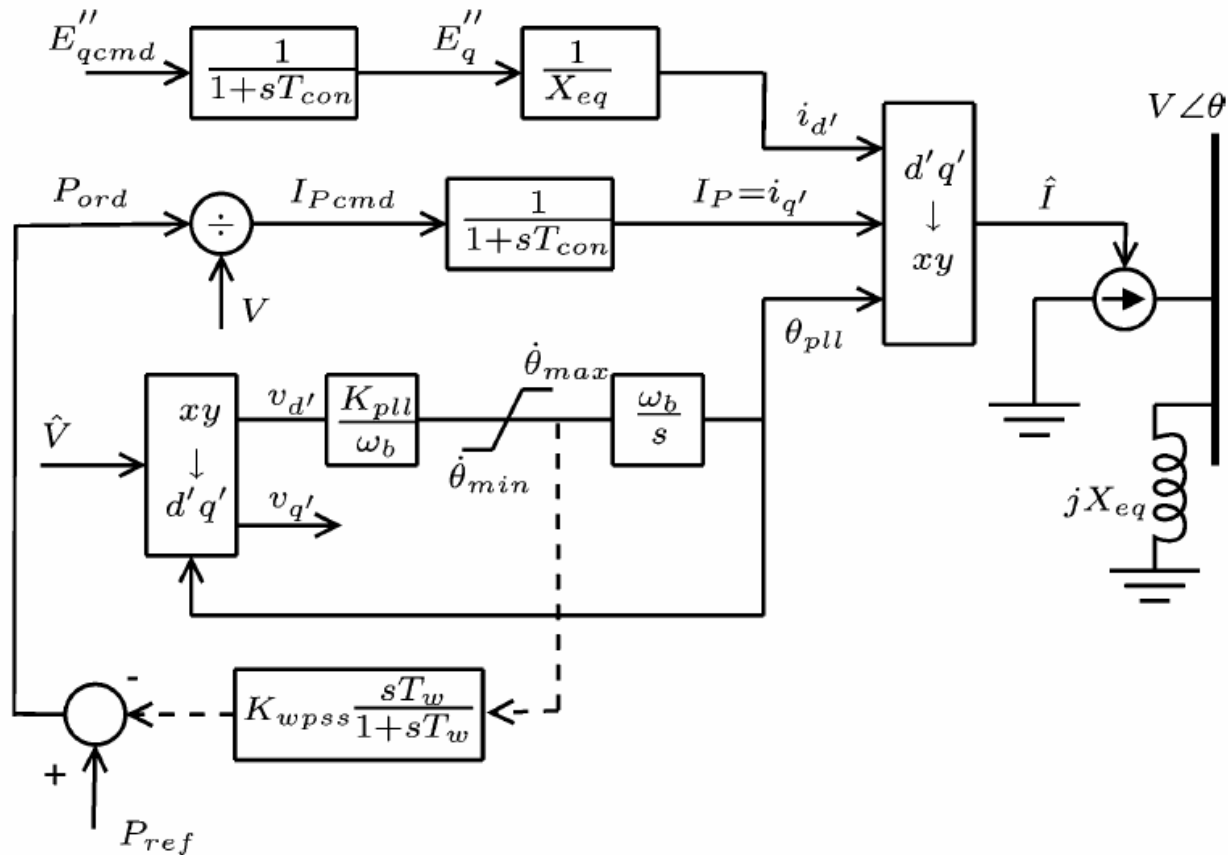

Wind PSS (2)

- ⌘ Case of 45 MW, DFAG in voltage control mode with TVC
- ⌘ Root locus for WPSS gain values 0-1
- ⌘ Interarea oscillation damping increase
- ⌘ Shaft mode damping decrease

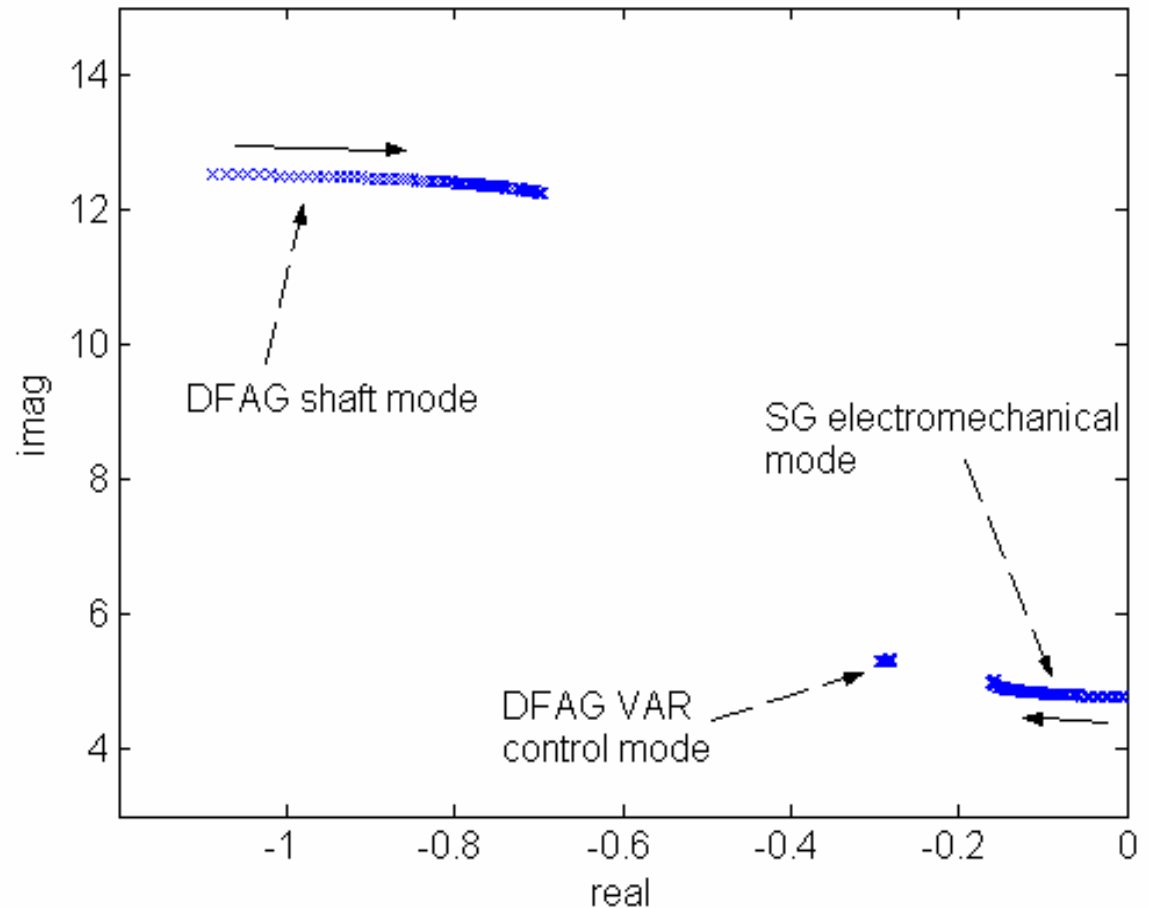

Wind PSS (3)

⌘ Fault simulation with and without Wind PSS (45 MW of wind)

⌘ $\zeta > 3\%$

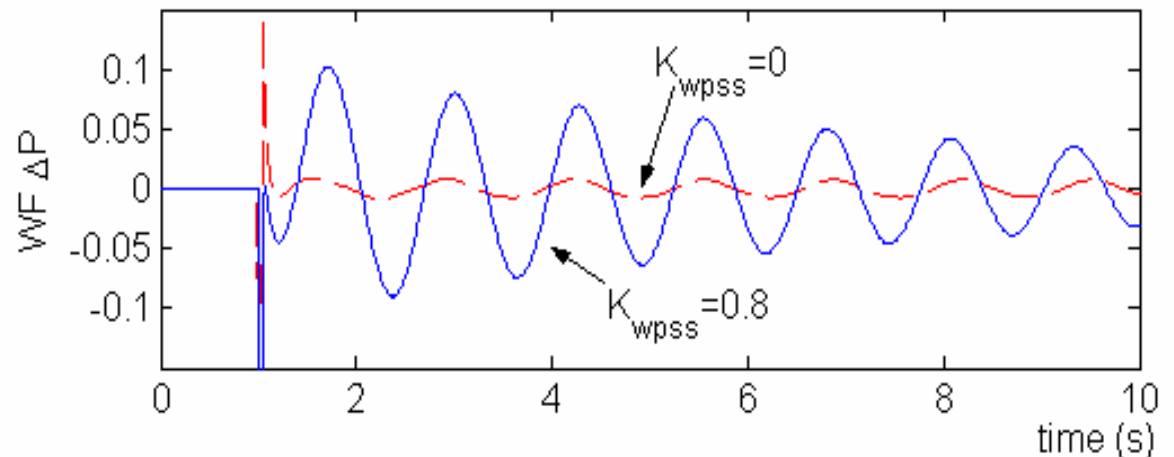
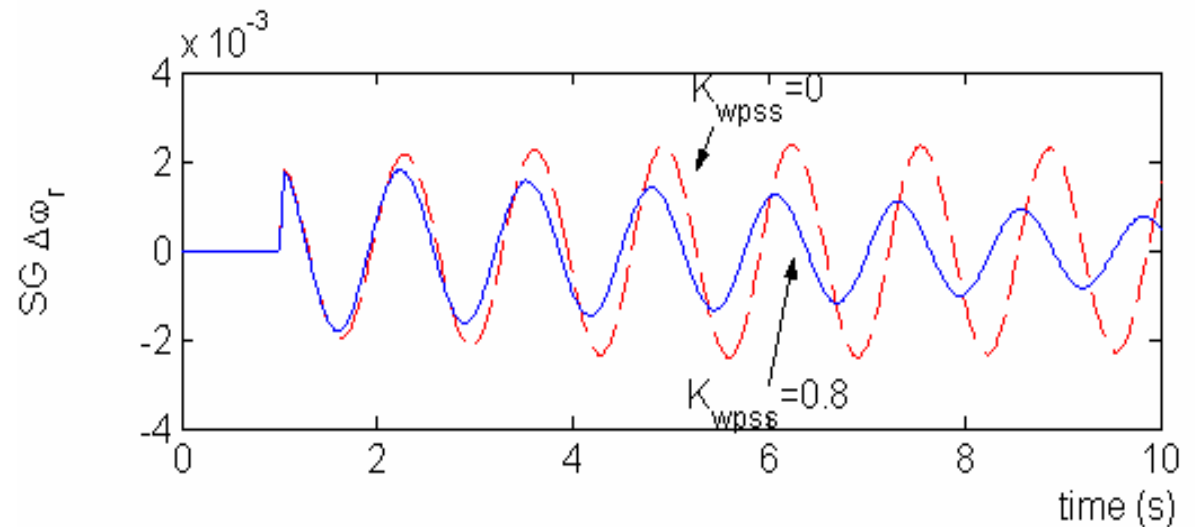

Hellenic system case study (1): system model

- ⌘ Model of HV and EHV system of Greece & EHV system of rest of South-Eastern part of UCTE interconnection (Balkan peninsula) in PSS/E (research project with HTSO)
- ⌘ Total load of Hellenic (Greek) system: 12 GW (2012 peak estimation)
- ⌘ 2500 MW from wind power, 1890 MW of DFAGs (GR)

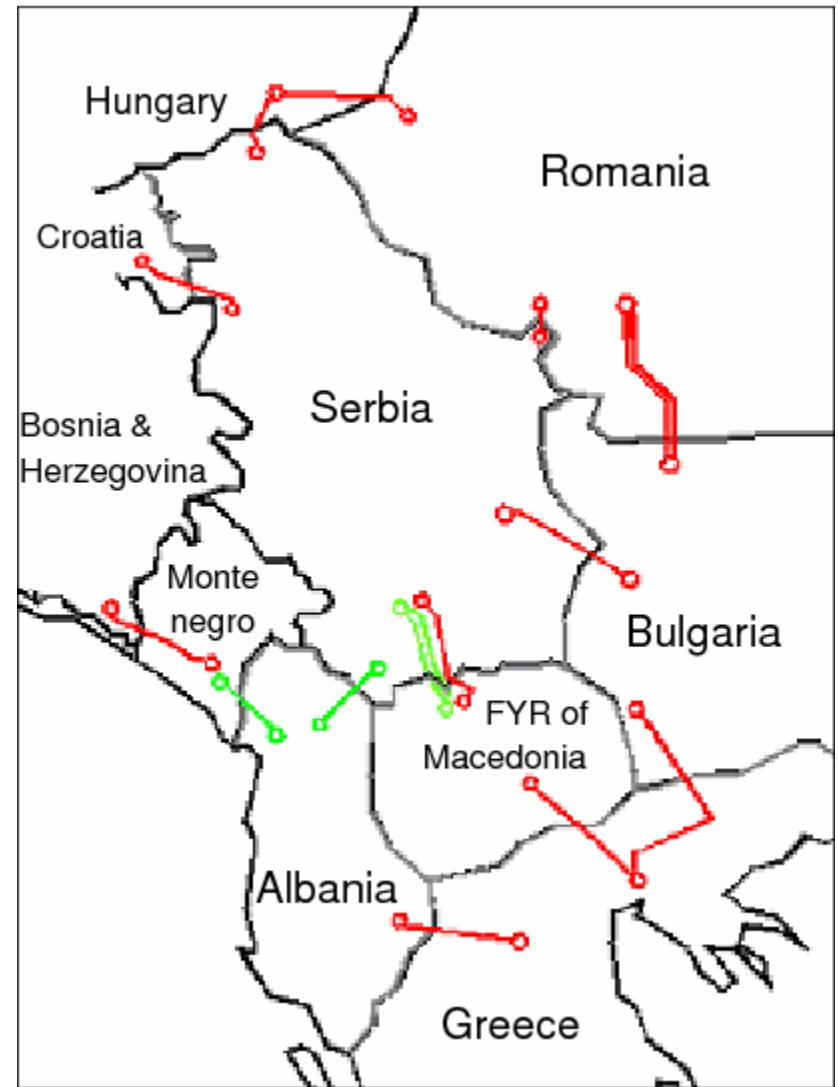

Hellenic system case study (2): base case

- ⌘ Base case: DFAGs modeled as constant admittances (approx. cancels out with part of the load)
- ⌘ Base case oscillation modes with light damping:

No.	eigenvalues	ζ	Hz	Mode
1	$-0.391 \pm j9.53$	0.041	1.52	Local VHSES1K
2	$-0.415 \pm j7.86$	0.053	1.25	Local JHBBAS G1-G2
	$-0.415 \pm j7.86$	0.053	1.25	Local JHBBAS G3-G4
3	$-0.397 \pm j7.78$	0.051	1.24	Local JHBBAS G12-G34
4	$-0.408 \pm j7.69$	0.053	1.22	Intra-GR POLUF-ALOUM
5	$-0.359 \pm j6.18$	0.058	0.98	Intra-GR KOM-MEG
6	$-0.403 \pm j5.38$	0.075	0.86	Intra-area AL-GR
7	$-0.423 \pm j3.45$	0.122	0.55	Interarea GR
8	$-0.329 \pm j1.29$	0.248	0.20	Interarea UCTE

Hellenic system case study (3): effect of DFAG modeling on GR interarea mode

DFAG Modeling	Linearization		Prony	
	f (Hz)	ζ	f (Hz)	ζ
GB	0.55	0.122	0.55	0.133
DFAG-PF with TVC	0.54	0.134	0.55	0.145
DFAG-PF w/o TVC	0.55	0.146	0.55	0.156
DFAG-VC with TVC	0.55	0.140	0.55	0.150
DFAG-VC with TVC, $K_{Qi} = 0.1$	0.54	0.141	0.54	0.155
DFAG-VC w/o TVC	0.55	0.151	0.55	0.165

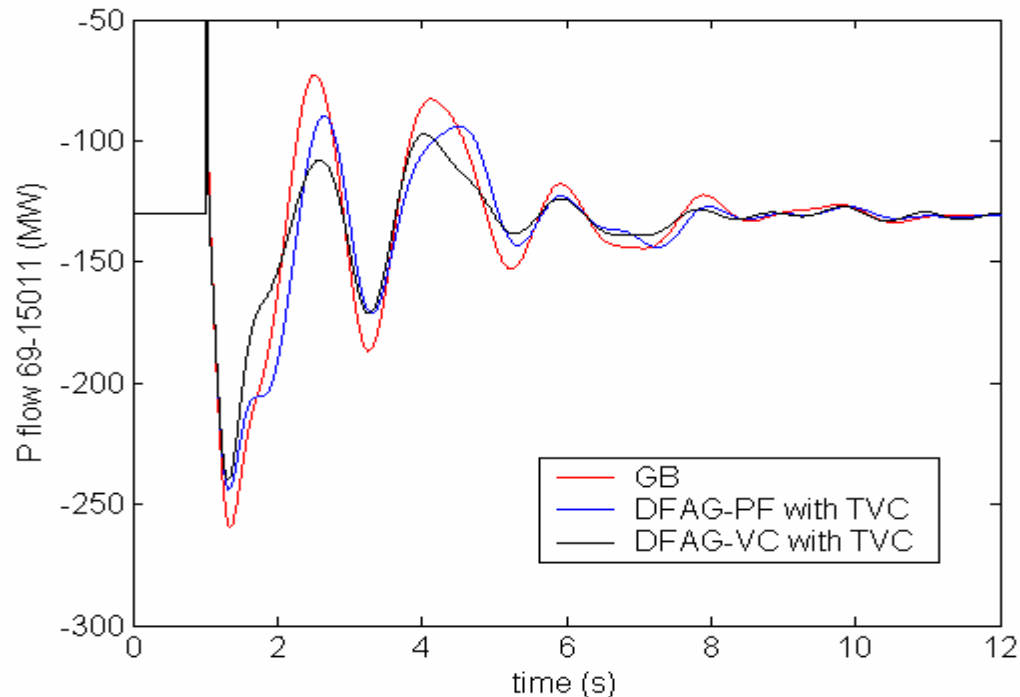

Hellenic system case study (4): tuning of DFAG reactive power control

- ⌘ Case of DFAG in voltage control mode with TVC
- ⌘ Some of the VAR control oscillation modes appear with low damping
- ⌘ Tuning by reduction of gain K_{Qi}

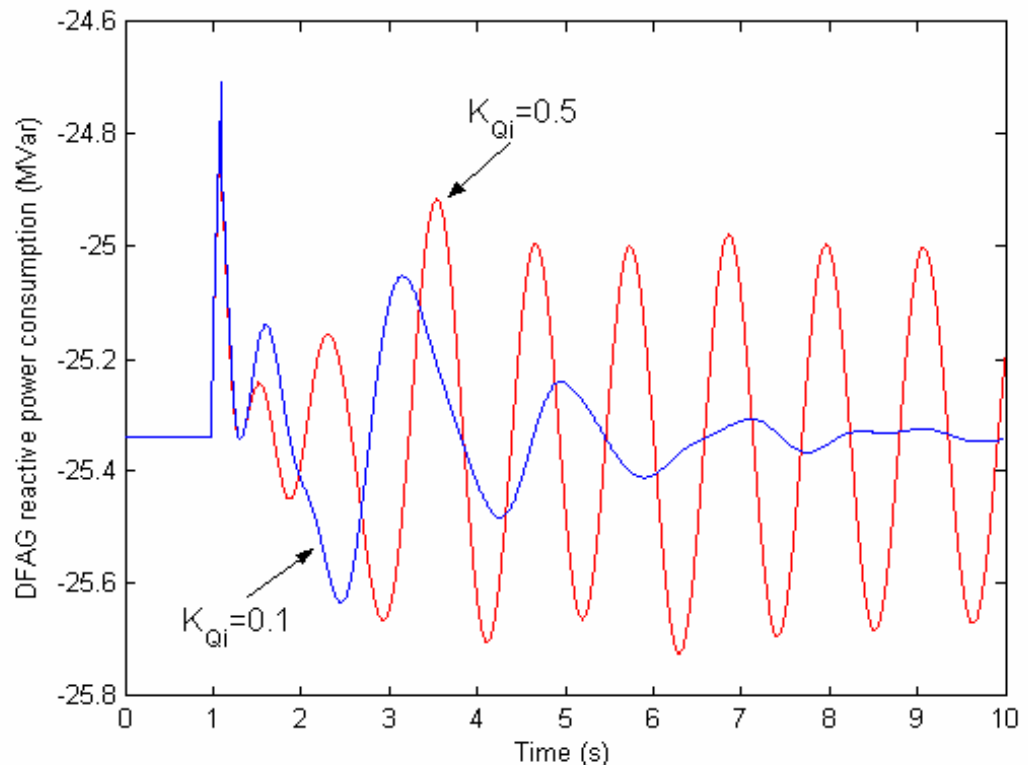

Conclusions



1. Wind power generally improves oscillation damping
2. Care should be taken for appropriate tuning of control loops
3. Wind PSS:
 1. Simple (no special design of lead/lag compensators),
 2. Also adds inertia,
 3. Needs to be implemented in every machine