

# DER inverter testing

**Dominik Geibel**

**Fraunhofer Institute for Wind  
Energy and Energy System  
Technology  
(IWES)**



**Omar Perego**

**Ricerca Sistema Energetico  
(RSE)**



**2011-10-06  
Kassel**

**DERlab**

- Introduction
- PV inverter testing according to grid codes (D. Geibel / IWES)
- PV inverter round robin tests (O. Perego / RSE)

# Content

- Testing possibilities of DERlab
- European grid codes and test procedures
- Confirmation of electrical properties according to grid codes
- Development of test procedures
  - Example: PV-specific test procedure for Fault-Ride-Through capability



# DERlab Inverter Testing - Introduction



- DERlab provides a great variety of testing facilities in terms of
  - power ranges,
  - generation technologies,
  - network assets
- Focus of testing capabilities ranges from pure academic to commercial



- Power range from small residential to industrial range (several MVA)
- Laboratories complement each other
- Between DERlab laboratories exchange of test results and personal e.g. in frame of round robin test take place



- Steady state requirements:
  - Limitation of power-quality characteristic parameters (voltage change, harmonics, flicker)
  - Active power control (reduction)
  - Reactive power control
  - Protection functions
- Transient behaviour:
  - Fault-ride-through (FRT) capability during voltage dips
  - No change of active power
  - Feed-in of reactive current during the fault
  - Limitation of short-circuit current

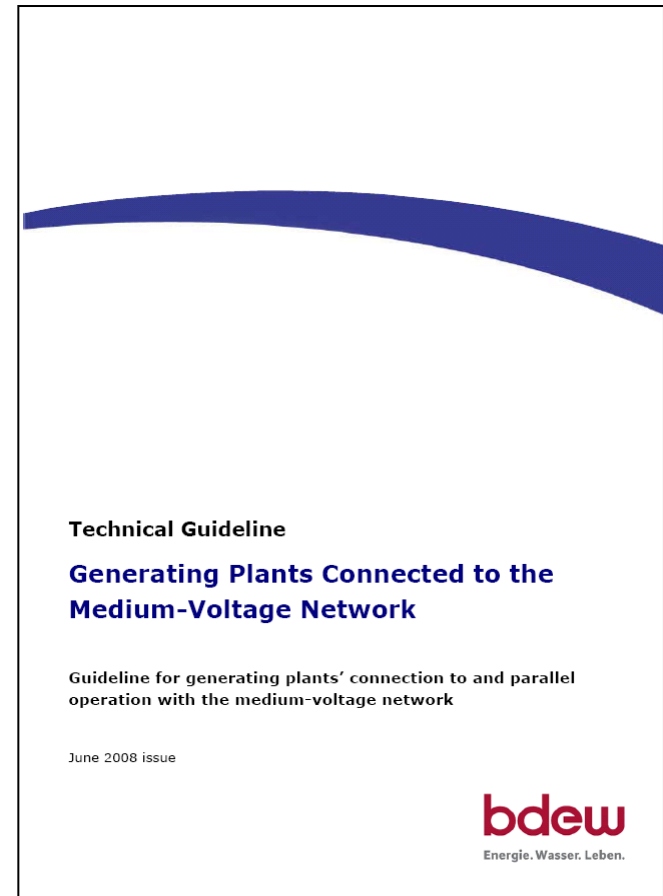

# European Grid Codes

- Country-specific grid codes
- Introduction of certification process
  - Confirmation of electrical properties by measurements
  - Validation of simulation models
  - Same functionalities have to be tested in every country
- European test procedures
  - Comprehensive and validated test procedures
  - CLC/FprTS 50549-1 and -2

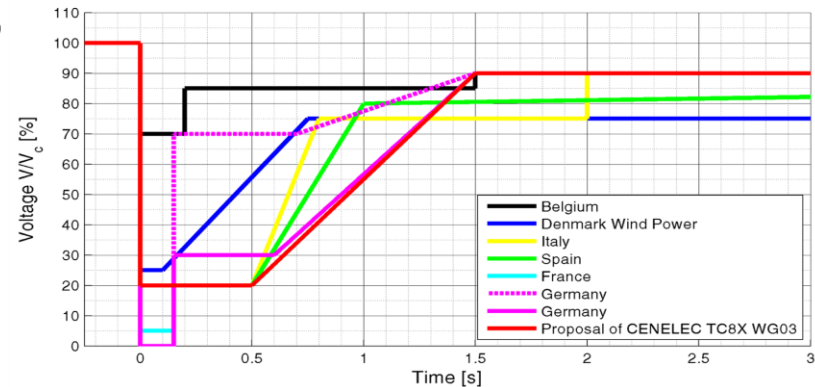
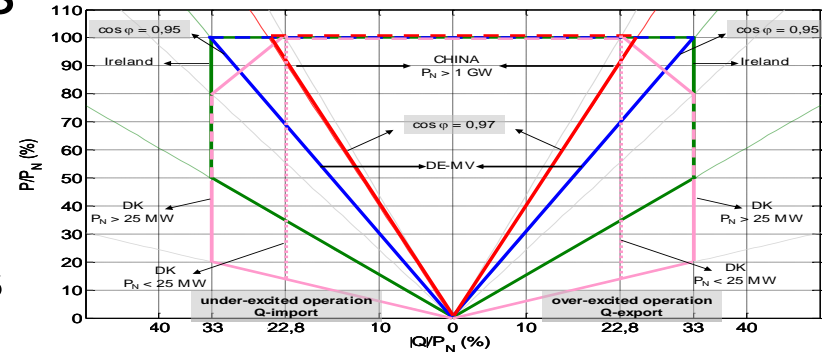

# Test procedures for DER units

- Existing test procedures
  - Wind turbines IEC 61400-21
  - Not suitable e.g. for PV systems
- Adaptation process
  - All kinds of DER units have to be respected
    - Wind, photovoltaic and biomass
  - Primary energy source
    - Influence on behaviour of DER unit has to be considered
  - Widely varying power ratings of DER units have to be covered
    - Some few kW up to several MW
- Process carried out during last 2-3 years in Germany



# Test procedures for DER units

- FGW TR3
  - Measurement methods and test procedures for approval of the grid behaviour of DER units according to the MV-Distribution Code (valid: Rev.22, 01.07.2011)
- Modifications for PV systems
  - Solar module independent testing
    - either on-site but also inside a lab with „appropriate“ simulators
    - DC-Source (PV-simulator) characteristic is described
  - Procedure for testing of network faults also at LV level
    - Originally only test procedure for test at MV-level



# General measurement setup

- Power acquisition
  - Voltages and currents on DC and AC part of PV-inverter
- Set-point signal acquisition
  - Synchronous measurement of power and set-point signals
- Generation of set-point signals
  - RS 485 signals from PC to the PV inverter
  - Generation of set-point signals for digital and analogue interfaces with PLC

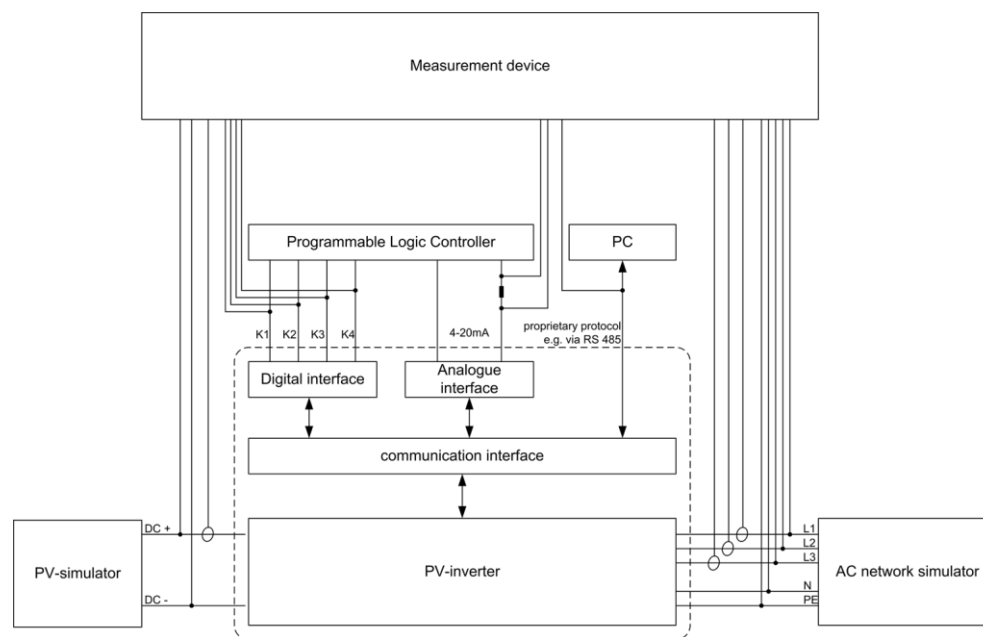

- Behaviour depends on:
  - Depths of voltage dip
  - Fault duration
- Test infrastructure
  - FRT-containers
  - mainly known from wind turbine testing
- Tests for certification
  - balanced/unbalanced
  - different voltage dips and times
  - different k-factors
  - different active power

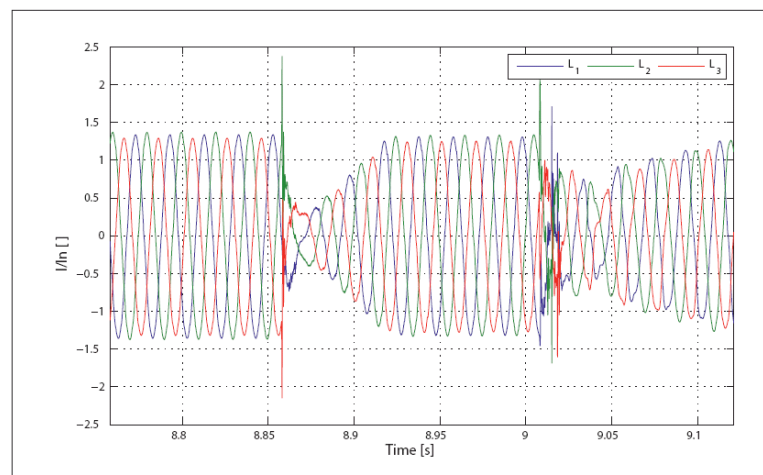
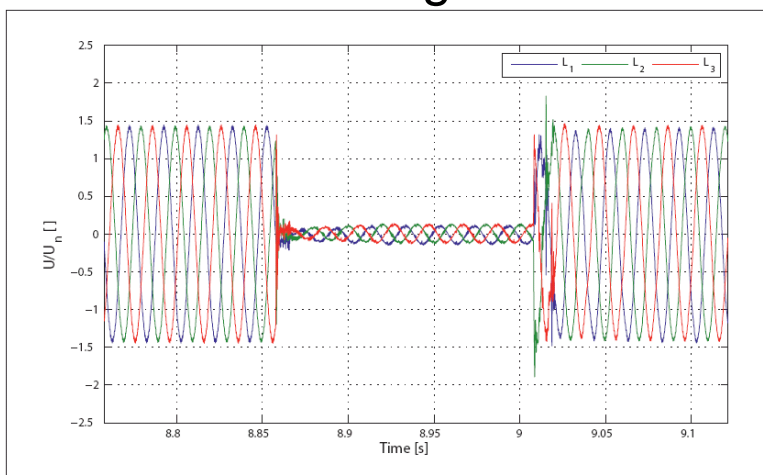

# PV-specific test procedures – FRT

- Nominal network voltage
  - 10 / 20 kV
- Rated power of the EUT
  - 0.25 to 6 MVA
- $S_k$  at the PCC
  - 80 to 350 MVA
- Housing
  - 40-foot Maritime High Cube container

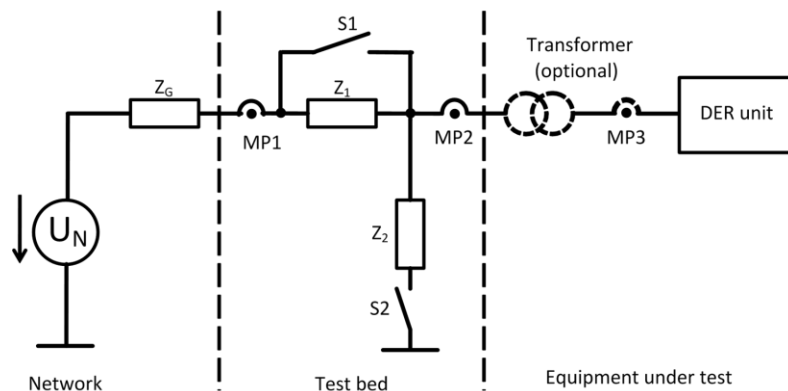

# PV-specific test procedures – FRT

- Challenges
  - Power ratings of string inverters are in general too low for usage of common FRT containers (>100-250 kVA)

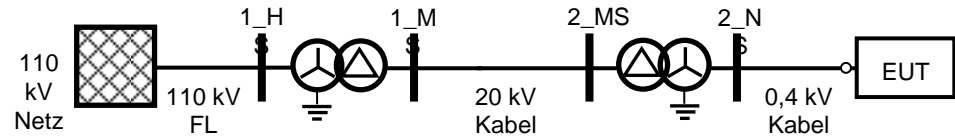

- Enhancement of test procedure
  - Test at LV level is allowed if the faults have the same behaviour as if they were generated at the MV level
  - The vector group of the MV/LV transformer has to be considered, especially for unbalanced faults.

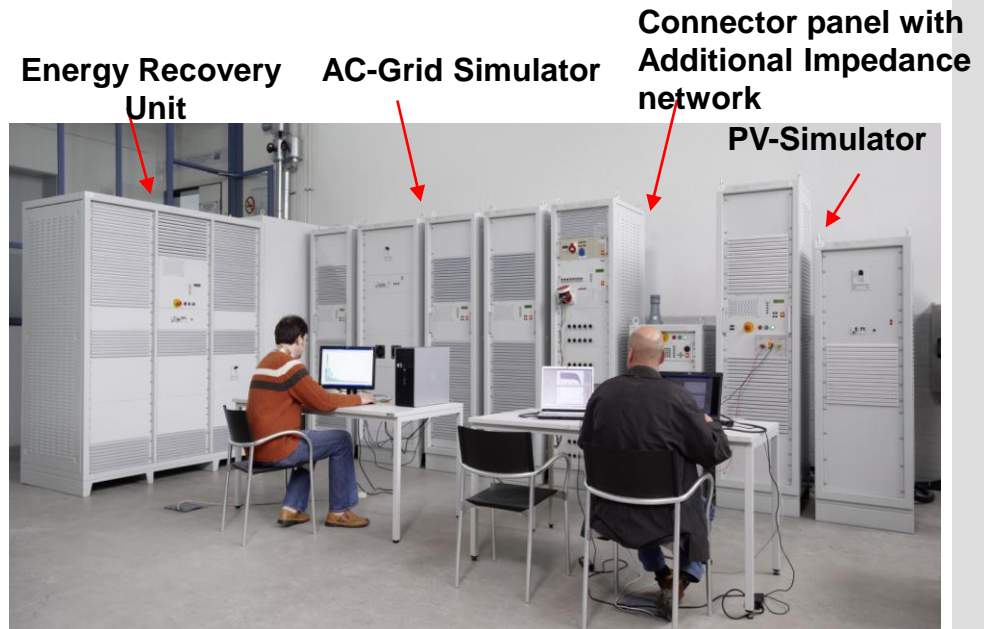

- FRT tests with LV network simulator
  - Real reproduction of voltage curves with low ohmic programmable AC sources
  - Real emulation of network impedance by adjustable R-L-network
  - Consideration of MV/LV transformer and park cabling
- Requirements for LV network simulator
  - Independent control of voltage amplitude and phase angle of each line
  - High slew rates
  - Adjustment of short-circuit power and network impedance angle

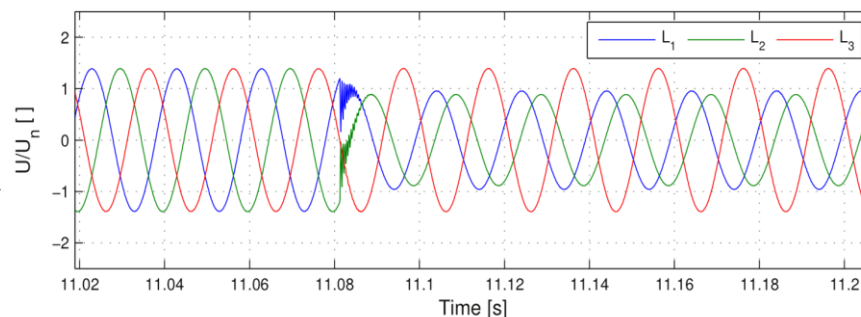
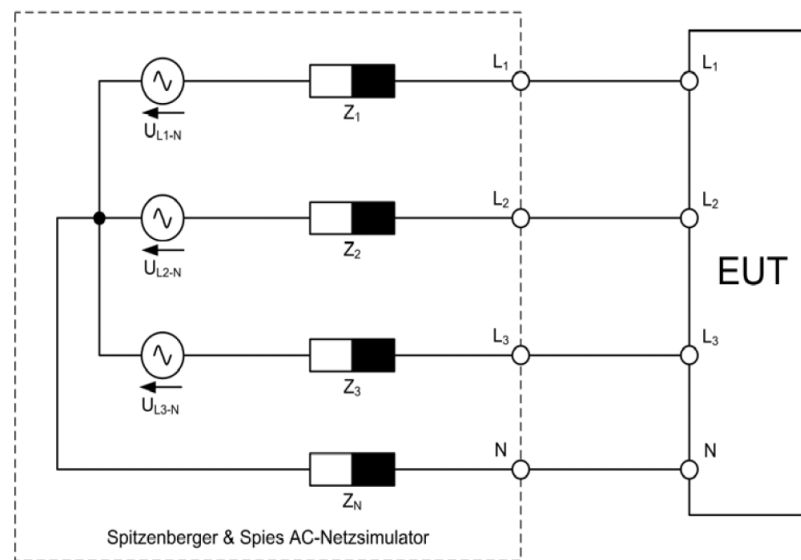

## Conclusion



- Certification process of DER units became an import task in order to verify functionalities requested by national grid codes
- Common European test procedures for harmonised European grid codes had been introduced and have to be further developed
- DERlab supported these tasks by developing and validating new test procedures



**DER-lab workshop Kassel  
6<sup>th</sup> October, 2011**

**DER Testing procedures  
PV Inverter Round Robin test  
Omar Perego**

# Photovoltaic Inverter **ROUND ROBIN** test

## Agenda

- Purposes of this work on Electrical Interconnection of DER
- Method of this work:
  - Definition of Photovoltaic Inverter testing procedures;
  - Validation Method: Round Robin test of 2 PV inverters in 9 European laboratories (DERlab consortium)  
(Tests on single-phase inverters, connected to PV field, up to 6 kVA of rated power, for functioning in parallel to the grid).
- Description of some results
  - i.e. MPPT accuracy when a PV shadowing occur
- Conclusions

## Purposes of this work:

As most of DER electrical systems are connected to the grid through **inverters**, we decided to pay a particular attention to the testing procedures for this kind of devices.

The aim of this work is

- to assess the behavior of PV inverters functioning in parallel to the grid and
- to measure the performances and characteristics of the PV inverters in different operative conditions.

The objectives are:

- to check the real use of inverter test procedures in different Laboratories
- to identify the gaps in the standardization of testing procedures
- to give suggestions to standards committees, in order to fill the gaps, to harmonize, to clarify etc.

Method of this work:

Why a Round Robin?



A team of experts from DER-lab partners has elaborated a document with the “**PV inverter testing procedures**”, related to performances, grid interface and safety.

This document couldn't be considered a “standard”, it is not produced by standard committees. It defines some steps that each lab has to follow to test PV inverter characteristics.

2 PV inverters have been tested in 9 European laboratories (within DERlab consortium)

Each lab has highlighted problems and difficulties occurred during these tests.

The main purpose of a “**Round Robin**” is to face these problems in order to **collect suggestions** from different experts and transfer this experience to standard committees.

ITALIAN  
GRID CODE

## Tests

The tests performed, divided into [M]andatory and [O]ptional:

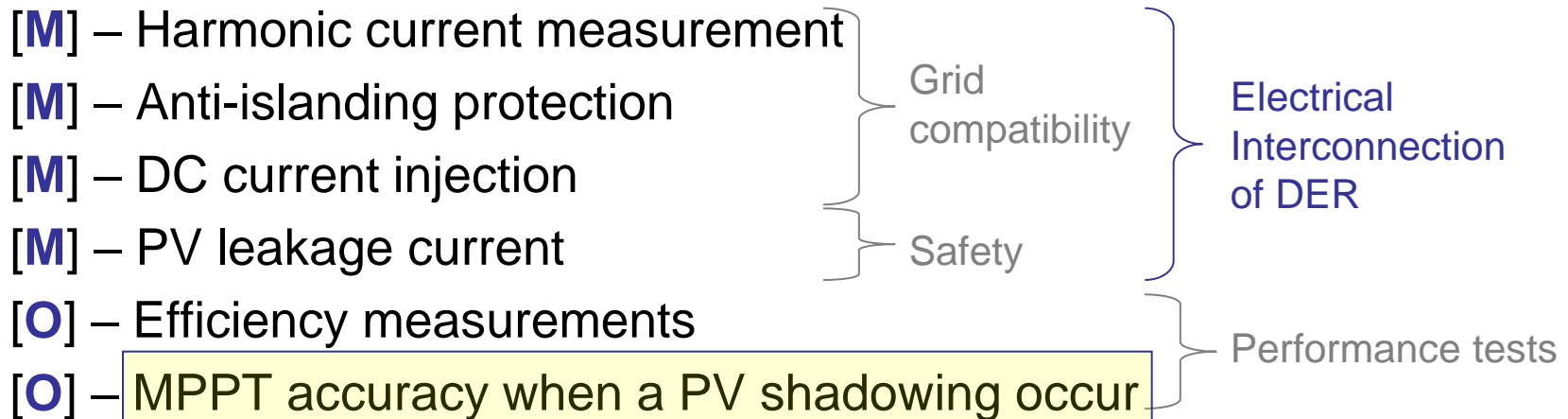

For each test, the necessary instruments and devices have been provided.

# I-V curve when PV shadowing occurs

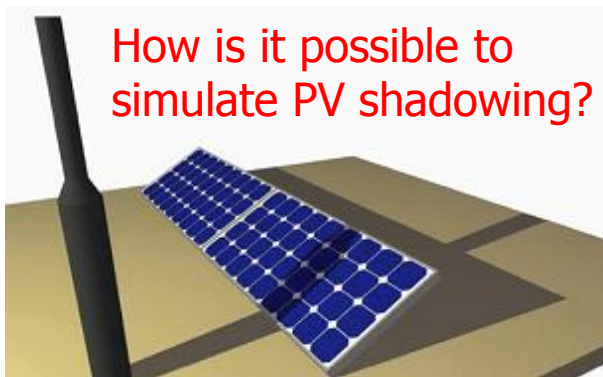
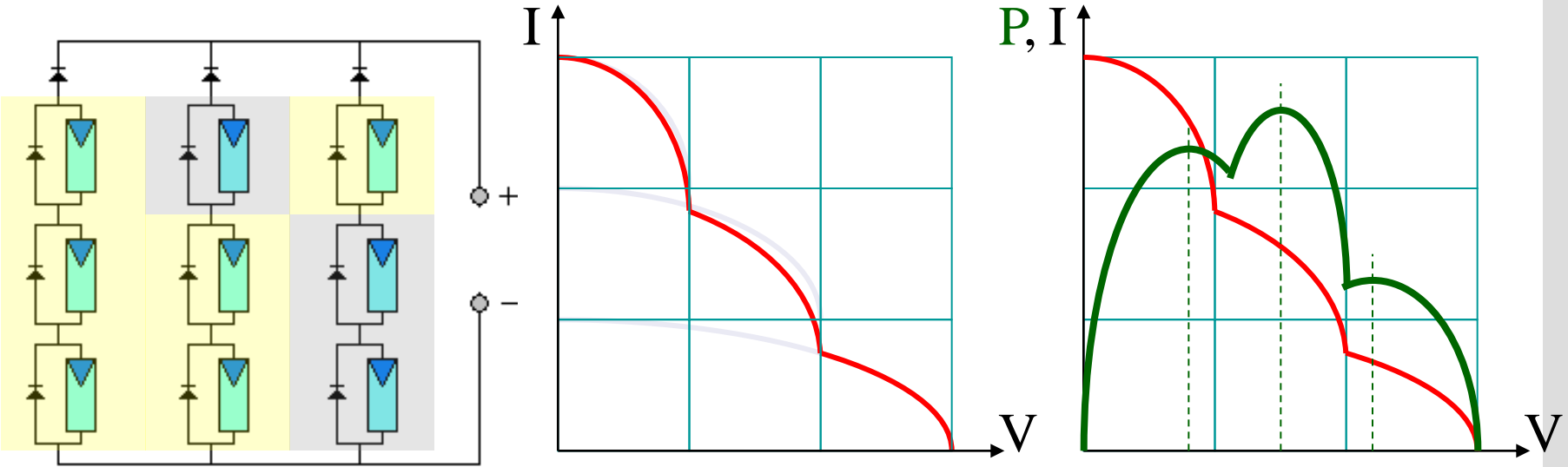

If one or more strings of a PV field have I-V curves different from other strings, the PV strings envelope produces a I-V curve with more “hills”.

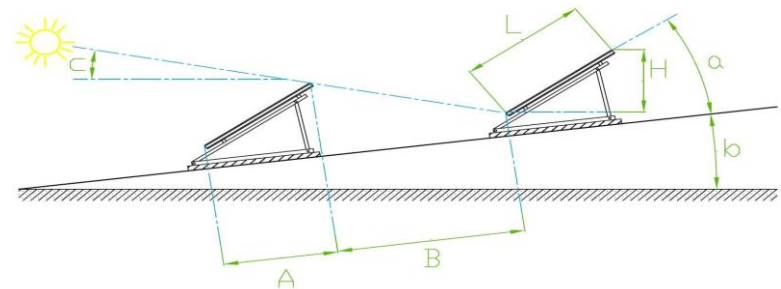

# MPPT accuracy when PV shadowing occurs

“performance” measurement

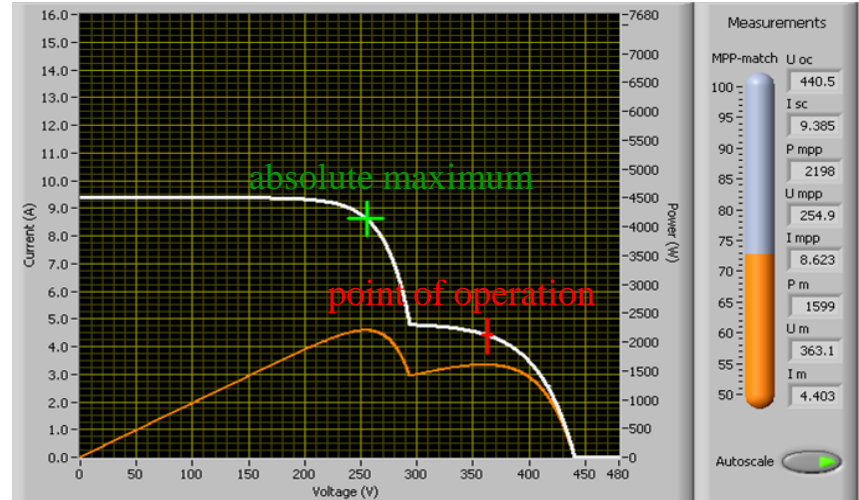
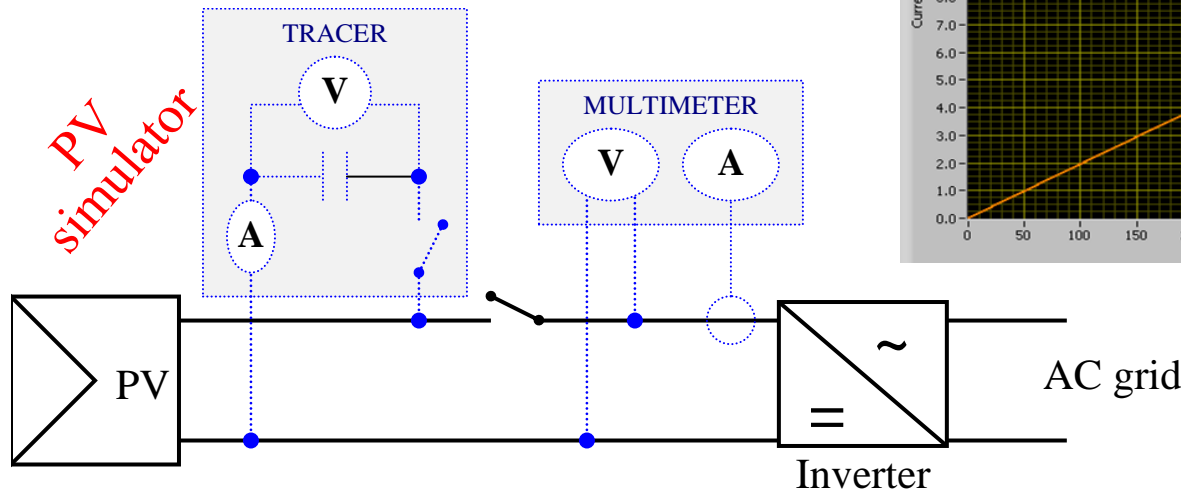

- Inverter has 2 channels with independent MPPT: test on one channel;
- 2 measurements:
  - ✓ Inverter tracking accuracy at operating in the maximum peak power (MPP) when PV shadowing occurs (test repeated);
  - ✓ Verification that the MPP found is the absolute maximum (TRACER)

## General RESULTS:

General problems occurred during tests and gaps in the procedures ...

- The testing procedures mainly depend from each **COUNTRY GRID CODE**. A grid code at EU level should be subscribed by member states, responding at different specific country requests. Eventually the EU grid code could be integrated by “specific test cases”.
- Unlike bigger inverters, a small scale inverter doesn't need advanced control algorithms (i.e. MPPT for shadowing); it is more important a work well performed by an installer. Test procedures must be improved in order to define the accuracy of advanced control algorithms.
- **DC-sources**: (PV-simulator, real PV-module, conventional DC-source?) to assure stability for the tests, most tests requires a [PV simulator](#) able to simulate radiation, temperature, configuration of the modules, etc. A [multi-string](#) inverter requires more than 1 DC-source.
- **AC-sources**: (AC-simulator, real grid?) to assure not disturbances on the measures and to get comparable results, an [AC-simulator](#) is preferred. The “Anti-islanding protection test” requires an AC-simulator in order to change grid parameters.

## Conclusions

The Round Robin test has been conducted, following the defined test procedures, with the **same inverters** under the **same test set up**, according with the **same standards** (with the Italian inverters parameters), but with **different devices, instruments and environment**.

A common understanding of the differences and remarks collected during the Round Robin has produced in the analytic phase:

- the **refinement of the testing procedures**
- the **elaboration of suggestions to standard committees**

**TC82** for PV, **TC64** for electrical safety, **TC8X** for grid interconnection, etc. **EMC?**

The work performed under Round Robin has been automatically forwarded to the relevant active standardisation groups, where the engineers involved on Round Robin are also directly involved in assessing and writing International and National Standards: the Round Robin has been used to assess, verify and modify existing and proposed test procedures.

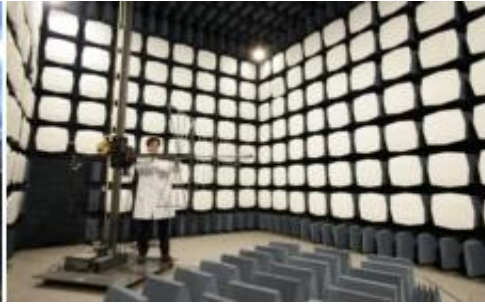

# DERlab

## Thank you!

**Dominik Geibel**

Fraunhofer Institute for Wind  
Energy and Energy System  
Technology  
(IWES)



**Omar Perego**

Ricerca Sistema Energetico  
(RSE)

