



Network of Excellence co-funded by the European Commission under the 6th Framework Programme within the thematic programme "Sustainable Energy Systems"



Contract No. SES6-CT-518299
NoE DERlab

Network of DER Laboratories and Pre-Standardisation

Project Deliverable 2.8: DER inverter white book

Due date of deliverable	2009-04	Actual Submission date	2009-09
start date of project	2005-11-01	duration	72 month
project coordinator name	Dr. Thomas Degner	project coordinator organisation name	Fraunhofer IWES Königstor 59 34119 Kassel/Germany
Organisation name of lead contractor for this deliverable:	Fraunhofer IWES	Organisation name(s) of co-contractor(s) for this deliverable:	Fraunhofer IWES

author(s):	Dr. Philipp Strauss (editor)
company:	Fraunhofer IWES
address:	Königstor 59, 34119 Kassel Germany
phone:	+49 561 7294 243
fax:	+49 561 7294 400
email:	bereich-a@iset.uni-kassel.de
further authors:	See chapter sections
reviewer:	Wolfram Heckmann
approver:	Dr. Thomas Degner

Document Information

document name:	DERlab_D2.8_whitebook_static_converters_rev0.doc
revision:	0 (Final)
date:	2009-09-20
dissemination level:	public

INTERNATIONAL WHITE BOOK ON THE GRID INTEGRATION OF STATIC CONVERTERS

Philipp Strauss (Editor)

[European Distributed Energy Resources Laboratories](#) (DERlab) e.V.

c/o Fraunhofer IWES

Koenigstor 59, 34119 Kassel, Germany

Phone: 49(561)7294243, Email: info@der-lab.net

ABSTRACT

Power electronic converters are the key elements to support the massive integration of distributed renewable energy resources (DER) into electricity grids. This white book deals with the future requirements for static converters that can contribute actively to a smart operation of the power systems considering in particular ancillary services, disturbed network conditions, and control and communication requirements. The aim of this paper is to collect first ideas for pre-standardisation needs concerning the behaviour and control capabilities of a huge amount of converters in the electricity grid. This working paper was initiated by the DERlab European Network of Excellence and is a result of a first series of workshops that was open to experts in the field.

ACKNOWLEDGEMENT

This work was co-financed by the European Commission within the NoE DERlab (SES6-CT-2005-518299). The authors are solely responsible for the content of this publication. It does not represent the opinion of the European Community. The European Community is not responsible for any use that might be made of data appearing therein.

Revision Number	Revision Date	Revision Comment
0	2009-09-15	First full public draft

Table of contents:

Chapter 1: Ancillary services_____	5
Chapter 2: Behaviour under fault conditions_____	29
Chapter 3: Control and Communication for operation of inverters in future power systems_____	75

INTRODUCTION

Facing the enormous growth of decentralised generation (DG) connected to the distribution systems, the coming years will bring fundamental changes for new generators to be connected by static converters. While in the past, generators connected to the distribution system were commonly not permitted to take over an active role and had to disconnect at “the first sign of trouble”, new grid codes now require the units to actively support the grid during normal as well as during disturbed conditions - a step that is commonly seen as being absolutely necessary to guarantee reliability and quality of supply on the mid and long-term.

On this background the “European Network of Excellence of Distributed Energy Resources (DER) Laboratories –DERlab”(1) has started to prepare the “International White Book on the Grid Integration of Static Converters”. It aims at describing medium to long-term harmonisation needs for the behaviour and technical interfaces of grid connected static converters. It should support the preparation of international standards that describe controllable power units for:

- grid operators to assure grid compatibility of power devices that might contribute with ancillary grid services
- manufacturers to produce products that are applicable in different countries as well as
- operators to have devices available that are of well defined quality/compatibility and that can be used efficiently.

For developing and discussing the draft DERlab has held a series of workshops for international DER experts to discuss these new requirements and find a common vision for the grid inverters of the future. The first outcomes of these workshops are documented in this white book. The main findings of the chapters “Ancillary services”, “Behaviour under fault conditions”, and “Control and Communication for operation of inverters in future power systems” are presented here. Up-to-date information on the white book and the workshops can be found at <http://www.der-lab.net/workshops> .

CHAPTER 1: GRID INVERTER ANCILLARY SERVICES

Authors:

- Aitor AMEZUA* *Grupo Ormazabal, Barrio Basauntz, 2, E-48140 Igorre, Bizkaia (SPAIN)*
Phone +34 946 305 113, Fax +34 946 305 112, ama@ormazabal.com
- Grzegorz BENYSEK* G.Benysek@iee.uz.zgora.pl
- Martin BRAUN* *Fraunhofer IWES, mbraun@iset.uni-kassel.de*
- Stephen FINNEY* s.finney@eee.strath.ac.uk
- Zbigniew HANZELKA* *AGH-University of Science and Technology*
Faculty of Electrical Engineering, Automatics, Computer Science and
Electronics
Al. Mickiewicza 30, 30-059 Kraków, POLAND
Phone: (48) 12 617 28 78; 12 617 2801, hanzel@agh.edu.pl
- Ryszard KLEMPKA* *AGH-University of Science and Technology*
Faculty of Electrical Engineering, Automatics, Computer Science and
Electronics
Al. Mickiewicza 30, 30-059 Kraków, POLAND,
r_klempka@pwszstar.edu.pl
- Tom LOIX* tom.loix@esat.kuleuven.be
- Joseph MUTALE* *University of Manchester*
j.mutale@manchester.ac.uk
- Ryszard PAWEŁEK* *Technical University of Lodz, Institute of Electrical Power Engineering*
Ul. Stefanowskiego 18/22, 90924 Lodz, POLAND
Phone: (+48 42) 631 25 96; 636 11 93, rpawelek@p.lodz.pl
- Jose Emilio RODRIGUEZ* *LABEIN-Tecnalia, Parque Tecnológico, 700*
48 160 Deria, Bizkaia, SPAIN, emilio@labein.es
- Gabrio SUPERTI FURGA* gabrio.supertifurga@polimi.it
- Paul VAN TICHELEN* paul.vantichelen@vito.be
- Irena WASIAK* *Technical University of Lodz, Institute of Electrical Power Engineering*
Ul. Stefanowskiego 18/22, 90924 Lodz, POLAND
Phone: (+48 42) 631 25 96; 636 11 93, irawas@p.lodz.pl
- Eduardo ZABALA* *LABEIN-Tecnalia, Parque Tecnológico, 700*
48 160 Deria, Bizkaia, SPAIN, ezabala@labein.es

ABSTRACT – This report concerns ancillary services accomplished by power electronic converter connecting Distributed Energy Resources (DER) with supply network. The meaning of the term "ancillary services" applies to all additional functions of converters beyond their basic task, i.e. transferring active power/energy in the form suitable to be converted into other forms of energy, adequate for intended purposes.

No limits have been set on the converter power (from kW to MW), or on the voltage level at which they are connected to the supply network, both the single-phase and three-phase. The only condition is their co-operation with AC distribution power networks.

For the purposes of this report the converter is considered to be a black box connected to the power system. The objective is to define: (a) new tasks, resulting from the needs of energy sources, systems operators and end users that designers of converter can/should undertake and (b) the standardization gap with respect to the converters that perform ancillary services.

Keywords: ancillary services, distributed energy resources (DER), power quality, active and reactive power control, power system, inverters

CONTENTS

1. INTRODUCTION
 - 1.1. Ancillary services
 - 1.2. Present provision of ancillary services by DER
 - 1.3. Future provision of ancillary services by DER
 2. STATIC POWER CONVERTERS
 - 2.1. General converter requirements for ancillary service
 3. ENERGY PRODUCERS
 4. SUPPLY NETWORK
 - 4.1. Dispatching
 - 4.2. Voltage regulation and P-Q control
 - 4.3. Potentiality of grid-connected inverters in power supply conditioning
 - 4.4. Power quality distributed control system
 5. END USERS
 6. EXPECTATIONS FOR STANDARDS
 - 6.1. Emission standards
 - 6.1.1. Harmonics
 - 6.1.2. Unbalance
 - 6.1.3. Rapid voltage changes
 - 6.1.4. Voltage fluctuations (flicker)
 - 6.1.5. DC Injection
 - 6.2. Immunity standards
 - 6.3. Type testing
 7. CONCLUSIONS
- ACKNOWLEDGEMENTS
- BIBLIOGRAPHY

1. INTRODUCTION

The two main energy policy objectives in the European Union are to ensure sustainability and security of energy supplies. In practical terms, this requires, among other things, a reduction in greenhouse gas emissions and minimising the dependency on imported fossil fuels. The use of local Distributed Energy Resources (DER) can contribute to the attainment of these objectives.

In some countries, incentive systems have been instituted to boost investments in DER. The main objective in many of these countries is for the DER to supply maximum active power. However, in the future the need for DER units to actively support network operation will increase. With a high proportion of DERs in power generation, these units should also cover a similar range of control tasks as conventional power plants in order to maintain or even increase the efficiency, quality and security of the power supply system. The small size Distributed Generation (DG) and DG with variable power generation can be aggregated, e.g. in virtual power plants, in order to be able to provide the required services efficiently and substitute conventional power plants effectively. Providing the required ancillary services, aggregation of highly flexible small DER units has the potential to become a key part of the overall EU network infrastructure reinforcement and replacement strategy.

DER could provide a range of ancillary services on distribution level. The provision of these services will be influenced by primary plant operating regimes and characteristics, equipment control capabilities and information infrastructure. The overall value of these services is driven by the costs of traditional solutions such as conventional generators and network reinforcements. As penetration of DER increases displacing central generation, the competitiveness of ancillary services from DER is expected to rise because the cost of ancillary services from conventional generating plant whose primary purpose will be to provide ancillary services, will become prohibitive.

Higher penetration of power electronics can be expected as use of renewable grows. It will necessitate the need for energy storage systems (ESS) which also involves power electronics

1.1. Ancillary services

According to the International Electrotechnical Vocabulary (IEV) "ancillary services" are the tasks to be performed by system operators and customers/users, necessary for the operation of transmission or distribution system that involve participation in voltage and frequency regulation, reactive power regulation, active power reservation, etc.

In this report the meaning of the term "ancillary services" has been modified. In its present form this term applies to all additional functions of converters, connected to the distribution supply network, beyond their basic task, i.e. transferring active power/energy in the form suitable to be converted into other forms of energy, adequate for intended purposes. Energy conversion with improved efficiency has also

been categorised into the "ancillary services" in a broad sense. No ancillary services on the transmission level and under island operation are considered.

This approach allows concluding that converters, apart from the increasing of the reliability of electric power supply, can be employed for the following general purposes:

- Essential for energy producers:
 - effective energy generation
 - increasing of "hosting capacity" i.e. the highest amount of DG that can be integrated without the grid performance limit being violated [2].
- Essential for the power supply network operator¹:
 - increasing the functionality and efficiency of electric energy conversion and transfer (control of active and reactive power flows, power losses reduction, etc.)
 - improvement of voltage quality at the power system level (e.g.: voltage magnitude, voltage distortion and unbalance, voltage disturbances — dips, swells and short interruptions).
 - control of a large number of sources centrally
 - deferring distribution system upgrade.
- Essential for end-users²:
 - power factor improvement
 - power supply conditioning (sinusoidal, balanced voltage without voltage events)
 - reduction of electromagnetic disturbances emission from the users' equipment. From the perspective of the electric power supplier the user can be perceived as a linear, balanced load of resistive character.
 - increased effectiveness of energy consumption.

The aim of this report is mainly an attempt to answer the following questions:

- what problems, currently occurring in a power system, resulting from the needs of energy sources producers, distribution systems operators and end-users that designers of converter can/should undertake, can be solved by means of power electronic equipment:
 - new equipment not yet available on the market (to be designed and developed over the current decade), or
 - the existing power electronic equipment that by means of improvements will fulfil the present needs more adequately, on a larger scale, etc.

¹ To create the new supply power systems according to smart grid concept is not possible without the application of power electronic converters with more and more sophisticated control systems.

² Uninterruptible power supply systems are dealt with in Chapter 3.

- what new expectations have the energy producers, power supply systems operators and end-users, that would be met by newly designed power electronic equipment in the future?
- what new methods, e.g. for converter control, capable of fulfilling new tasks/needs, or those already known only in a better way, can be employed?
- what kind of constraints and obstacles affect the development of ancillary services delivered by converters?
- how does inverter rating and the type of energy source to which it is connected influence its controllability for accomplishing different functions?

The above questions are of technical character, it is however, unavoidable to put questions concerning the economic aspects of ancillary services performed that way. Would it be economically justified to provide the DER-inverter with additional functionalities instead to apply specialized converters? The answer for this question is outside the scope of this report.

A separate issue, discussed in the second part, is an attempt to fill the standardization gap with respect to the converters that perform ancillary services, i.e. to answer the question: what new standards or guides concerning DER power electronic equipment that perform ancillary services, should be implemented?

The above formulation of the problem implies that this report becomes a result of discussion of mainly two groups of experts:

- power electronic experts — within the scope of assessing new possibilities of power electronic equipment,
- electric power engineering experts — within the scope of formulating new needs arising from the operation of energy sources and supply networks.

1.2. Present provision of ancillary services by DER

Requirements for DER to provide ancillary services differ from country to country within the EU. In some countries DER must be able to control active power on the distribution system level by the network operator, who can activate it in the situations of congestions and other situations that endanger secure network operation.

Moreover, the participation in balancing markets is also possible for fossil-fuelled power plants in the size of some MW.

Grid codes in some countries already require a contribution of DER to voltage control by reactive power management. From an economic perspective two main cost categories have to be distinguished with regard to reactive power supply: investment costs and variable operational costs. Operational costs of reactive power supply are caused mainly by additional losses in the grid-coupling converter. Investment costs occur, if the grid-coupling converter has to be oversized in order to guarantee a certain reactive power capacity in all operational situations. The result of the costs-benefit analysis is that it is economically attractive to use distributed generators for reactive power supply in many situations. Most important for net-

work operation is the enhancement in reactive power reserves required to control and maintain network voltages within prescribed limits.

1.3. Future provision of ancillary services by DER

Assuming high increase in DER, say 50% of energy produced by DER, it would become necessary to rely on provision of ancillary services from DG. Thermal generating plants burning fossil fuels will continue to provide the balance of the capacity and ancillary services. However, these plants will be subject to a carbon tax or will operate under an effective and efficient “cap and trade” mechanism for emissions trading. This will ensure that their operating costs are higher than the cost of producing energy using generation that does not produce greenhouse gases therefore higher reliance on DG for provision of those services will not only be desirable but necessary as well.

It is clear that for the EU to fulfil its political objectives of ensuring sustainable and secure electricity supplies, it will be essential to provide an appropriate policy framework supporting system operation in the near future. If DER only displaces the energy produced by central generation but not the associated flexibility and capacity, the overall cost of operating the entire system will rise. In addition, the provision of ancillary services by DER will improve the viability of the DG projects.

The provision of ancillary services can, for example, be made compulsory by law (e.g. fault ride through requirements), and the services can be paid for on the basis of available capacity or by use (e.g. congestion management), or the services could be market-based and paid for at market prices (e.g. balancing services). Different approaches (payments by the distribution system operator to the providers for recovering the costs when the services are mandatory, negotiated or auctioned contracts, open market with bidding, etc.) can be explored in the search for an optimum solution, taking into account that, in general, it would be very difficult, if not impossible, to develop business cases for investing in DG solely on the basis of ancillary service income.

There is potential for distribution network ancillary service markets in parallel with the increase in electricity generation from DER and it is worth reiterating the importance of anticipating future ancillary services in the specification of requirements for grid inverters.

2. STATIC POWER CONVERTERS

The purpose of an electric power converter, which is only one element of interconnection system, is to provide an interface between the non-synchronous DER output and the supply network so that the two may be properly interconnected. Two broad categories of electric power converters can be used:

- DC-AC power converter (inverter). In this case, the input voltage to the device is generally a non-regulated DC voltage (fuel cells, photovoltaic devices, storage batteries, or AC generator through a rectifier). The output of

the device is at the AC voltage of appropriate frequency and magnitude as specified by the local utility. This is the dominant means of small and renewable DER interconnection.

- AC-AC electric power converter (direct or indirect). In this case, the input frequency and voltage magnitude to the device, or both, are not at levels that meet the network requirements (synchronous generator running at non-synchronous speed or an asynchronous generator). The output of the converter device is at the appropriate frequency and voltage magnitude as specified by the local utility.

DER can provide ancillary services, if they will be equipped with suitable static converter systems and become the object of adequate control. Of course, it may not be prudent to require that all inverters comply with requirements to supply all services. Rather a system of inverter classes could be conceived where the top class inverter provides fully flexible operation and lower class inverters could provide a limited range of important basic capabilities.

There is a trend toward the use of more integrated power electronics technology and to develop a modular universal interconnection technology – understood as a complex system connecting the energy source with the supply network. This idea would define a standard architecture for functions to be included in the interconnection system. These functions could include power conversion, power conditioning and quality, protection functions, DER (both generation and storage) and load controls, ancillary services, communications, and metering. The standard architecture would allow both DER manufacturers and end-users to easily integrate their power systems with the area EPS (Electric Power Systems).

For the purposes of this report the converter is considered to be a black box connected to the power system. The topology and structural features of power electronic systems are outside the scope of this consideration.

No limits have been set on the converter power (from kW to MWs), or on the voltage level at which they are connected to the supply network, both the single-phase and three-phase. The only condition is their co-operation with AC distribution power networks.

2.1. General converter requirements for ancillary service

The following requirements concern practically all converters that perform ancillary services, regardless of their function, topology, voltage, etc.:

- considering the field of application, there will always be the tendency towards increasing individual power of equipment. There is thus a constant demand for new semiconductor devices with increasing ratings — voltage, current and switching frequency³. The alternative solution is the modular

³ In electric drives, power throughput of matured single power converter has reached 10 MW. These high power converters switch at approximate frequency of 1 kHz. They operate at medium voltage 3.3 - 6.9 kV.

design of converters, as the large-power units are, as a principle, built from smaller modules - up to 30-100 MW which covers majority of renewable interface.

- For the above reasons (large powers) there will always be trend towards increasing the efficiency of energy conversion resulting from the necessity for both: the reduction of losses and elimination of forced cooling.
- A 3-phase 4-wire inverter would be most useful for LV applications, because it allows controlling in each phase independently (neutral balance capability). This also concerns four-wire output converter structure such, as not to convey the load unbalance to the side of local generators and therefore protect them from zero sequence and negative sequence components of currents and fluxes.
- In many applications (e.g. mitigation of voltage fluctuation, active filtering, reduction of the number of voltage events, etc.) a short time of converter response to a disturbance is needed.
- Historical trends in the preceding development of converter technology for low-power applications, and the recent impressive progress of power semiconductor technology, suggest that the new generation of power converter technology will employ the technique of pulse-width-modulation (PWM) as the basic method for output waveform synthesis together with the use of modular circuit structures to neutralize the resulting high frequency carrier component in the output and thereby eliminate or significantly reduce filtering requirements.
- The high switching frequency of semiconductor devices used in the converter structure enables more precise reproduction of the voltage and current reference signals and therefore improve the quality of an ancillary service being provided. High switching frequency allows the control bandwidth of the inverter to be raised giving improved response under non-ideal conditions.

Inverter connection requires the use of passive filters to attenuate switching frequency harmonics. Increased switching frequency ensures a greater frequency gap between the power and carrier harmonic frequencies, reducing component value and physical size of the passive filter.

Whilst raised switching frequency gives benefits it will have efficiency and cost penalties for the design (switching losses) particularly for high power systems). Simultaneously the high switching frequency is often the cause of higher order harmonics emission.

- Industrial and domestic applications require very often the DG/ES connection interface to generate high-quality electrical power, possibly close to the perfect sinusoid. This requires the invention of new power electronics topologies and hardware to provide solutions for low harmonic content and minimum EMI. It is proposed that while existing matrix and multilevel converter techniques are used as the baseline, novel topologies and controls must be developed to address specific system requirements within a DG,

and characteristics of the DG sources these converters use. Matrix converter techniques offer the ability to convert directly from AC to AC without the intermediate DC stage. The particular advantage of this approach is the elimination of the DC link capacitor.

Because of high generator output frequency integral pulse operation may be possible, leading to a significant reduction in losses. Multilevel converters offer, among other significant advantages, reduced harmonic distortion and EMI. Other advantages inherent in the topology are reduced switching losses and the possibility of using lower rate power devices. Lower device ratings imply faster switching speeds and lower losses. Special attention is paid to cascaded multilevel converters, with several separate DC sources. This arrangement should be the perfect DG/ES interface, because several batteries, fuel cells, solar cells, wind turbines, and micro-turbines can be connected through a multilevel converter to feed a load or the AC grid without voltage balancing problems.

- One of the expectations is certainly the reduction of converter price. Very often decisions are made to resign from very good converter solutions to passive ones (for example: resignation from active filtering to passive filters) that offer worse performance but are considerable cheaper. For the same reasons a purchaser often resigns from additional functionality, serving e.g. power quality improvement.
- As far as technology is concerned, the trend is toward an invisible (i.e., a plug-and-play) interconnection. Larger DER units typically have more stringent utility interconnection requirements as well as greater sitting complexity. Thus, there may eventually be two distinct DER markets: one for type-tested, plug-and-play, residential and small commercial units and one for larger site-specific DER.

3. ENERGY PRODUCERS

Renewable energy sources are characterized by strong variability of generated power. As a result of this instability the conditions in which maximum power can be obtained are varying. The use of power electronic equipment converting the generator energy enables optimization of the system operating point and ensures both: the maximum efficiency of energy generation and maximum energy output.

In the system with rotating sources of electric energy both the frequency and amplitude of the output voltage are independent from the generator speed. Therefore, the prime mover speed can be selected to ensure generator operation with maximum energy efficiency. At the same time the generator, usually designed for a higher frequency, will have smaller dimensions. Operation at high turbine speed may eliminate the need for mechanical transmission.

For an unintentional island in which the DER and a portion of the Area EPS remain energized through the PCC, the DER should cease to energize the Area EPS within limited time of the formation of an island. In most cases, it is not desirable for a DER to island with any part of the Area EPS on an unplanned basis. In this case the

basic expectations concerning the converters and their controls, are: fast switching of the source between the loads and the supply network, and effective detection of island operation.

4. SUPPLY NETWORK

Ancillary services have always been part of the electric industry, but only in recent years and supported by liberalization, their relevance has been recognized and they have been considered to be traded on a market basis.

The main task for a distribution network is electricity supply to consumers with high power quality and reliability. The network operation is influenced by disturbances, sources of which may be loads, distributed energy sources and the supplying network as well. Such disturbances may cause different problems which need to be tackled.

Distributed energy resources and disturbing loads can affect the supplying network operation in a similar way. They may introduce disturbances deteriorating power quality, such as voltage changes and continues fluctuations, harmonics and asymmetry.

In conventional distribution networks of radial configuration the negative deviation of node voltage is usually observed, which is the result of voltage drop on network elements. In a network with distributed generation both negative and positive deviations appear, the latter one leading to voltage rise. Some studies indicate that high levels of distributed generation may give rise to unacceptable levels of voltage rise.

Voltage fluctuations connected with the operation of some disturbing loads or some types of sources, eg. wind turbines, are the cause of flicker, which may be noticeable by customers. Keeping up the node voltage in the required range may be a crucial problem for utility.

Despite efforts to control low frequency conducted emissions from grid connected devices, the low voltage network remains subject to high levels of current harmonics and accompanying voltage distortion. For high penetration of inverter connected distributed generation the situation may arise where the network is required to supply the non linear component of local loading while contributing little in the way of real power. Voltage distortion depends on the network short-circuit power at the point of common coupling. Thus, harmonic current propagation follows towards the low voltage distribution grid. Single-phase low voltage loads or energy units contribute to current and voltage unbalance.

The separate issue apply to reactive power. The distribution network is responsible for meeting the VAR requirement of the local loads.

The source of electromagnetic disturbances can also be a supplying network. Bad voltage quality can cause the improper operation or even disconnection of loads and energy sources. The latter possibility may happen particularly during fault conditions. Such disconnections can upset a balance between power generation and demand. Because of the relatively low power of energy sources and loads installed

in distribution network, such a case can result in the excessive changes of node voltage.

Table 1 summarize various possible problems that can occur in distribution systems in both: the steady and transient states, as well as common methods for their solution, indicating those employing power electronic equipment (not necessarily co-operating with DER).

Table 1. The power quality problems occurring in distribution networks and power electronic equipment most commonly used to solve them

Voltage disturbances		Converter systems used to fulfil the task
Variations	Voltage magnitude, slow changes in voltage magnitude	DVR, SVC (TSC, TCR, FC /TCR, TCR/TSC), DSTATCOM, UPFC STCSB, AC/AC Continuous Voltage Regulators
	Voltage fluctuations	SVC (TSC, FC/TCR, TCR/TSC) DSTATCOM
	Voltage and current unbalance	SVC, DSTATCOM, UPFC
	Voltage and current distortion	APF
Events	Fast voltage changes,	DVR, DSTATCOM
	Voltage dips and swells	DVR, STS
	Short interruptions	STS, ESS, DVR
	Long interruptions	ESS
Note:	APF - Active Power Filter DVR - Dynamic Voltage Restorer ESS - Energy Storage System FC - Fixed Capacitor STS - Static Transfer Switch DSTATCOM - Static Synchronous Compensator (applied in distribution systems) STCSB - Static Tap Changers Series Booster SVC - Static VAr Compensator TCR - Thyristor Controlled Reactor TSC - Thyristor Switched Capacitor UPFC - Unified Power Flow Controller	

4.1. Dispatching

Integrating DER/ESS into the Area EPS offers special challenges for system dispatchers. Interconnection systems can be configured to be remotely dispatch able so the system operators can start up and stop operation of the DER remotely on a real-time basis. These systems can be more extensively employed than they are currently used for some applications including peak shaving, some emergency/standby power applications and could offer relief to the regional bottleneck as well as voltage and VAr support.

Traditionally, grid operators have built sufficient delivery capacity to serve the peak load, assuming one major malfunction. At the distribution level, this forces implementation of extra ties to other feeders; thus the load can be switched to an alternate feeder when a fault occurs. As a result, in a substation there must be enough capacity to serve the normal load and the extra load expected during failure; this results in overcapacity when the grid is in its normal state.

According to the technical (e.g. minimization of energy flow losses) or economic (e.g. minimization of energy generation cost) criteria, the central control system decides — controlling individually the converters — on the distributed sources share in fulfilling comprehensively the users'.

4.2. Voltage regulation and P-Q control

DER can contribute to voltage regulation in power system in two ways: directly, attempting to regulate the node voltages or indirectly, offsetting the load current thus changing the voltage drop in the network.

Most types of DER generators and utility-interactive inverters strive to maintain an approximately constant power factor at any voltage within their rating; accordingly, the primary impact of DER on voltage regulation is the result of the DER offsetting the load current.

When the inverter is grid-connected and PQ-controlled, the inverter can adjust its internal voltage to be able to provide the set points of P and Q. In grid-tied operation a current is injected. One fundamental limit is the maximum current transfer of the inverter. As long as the absolute value of the current does not exceed the limit, the phase angle of the current vector can be arbitrarily controlled with response times in the order of milliseconds. It is possible to control active and reactive currents independently from each other.

Analogous to the current domain, the power domains can be also looked at. These are of direct interest with regard to ancillary services. Instead of a maximum current, a maximum apparent power can be considered, with the same flexibility of active and reactive power control.

In order to verify the inverter's capability to participate in the control of the grid voltage magnitude some tests must be run. In order to check the operation during grid-connected mode (P-Q control), the tests should point out whether the inverter is able to achieve a certain minimum loading capability chart (defined as a certain area in the P-Q domain) for all active power loading situations and for all extreme situations (minimum/maximum voltage magnitude...).

In order to test the inverter operation for a range of operating conditions, it might be necessary to provide a grid connection with controllable impedance, in order to allow the inverter to exert a significant influence on the local voltage and check whether the control algorithm operates satisfactorily.

4.3. Potentiality of grid-connected inverters in power supply conditioning

In most applications front – end converter of DG unit does not work with the rated power and its over sizing engraves less then proportionally to power increase over converter cost. The considerations above make natural the aspiration to charge front – end converter with power quality tasks.

It is clear that a converter directly connected to the grid is not able to significantly affect the grid voltage, unless it exchanges large currents. The most frequently task which may be accomplished by front – end converters (particularly on LV level) is that of active filter for possibly distorting load currents. In order to act as an active filter, converters have to know the waveform of the distorting load currents. In other words, as shown in figure 1, arrangement of current sensors in section A-A or B-B is mandatory.

This way, by the mean of oportune control algorithms, deleting harmonic components and/or inverse sequences and/or shifted components is possible and this turns out in a waveform that approximates the ideal one (only first harmonic component balanced and in-phase with voltage). At the same time voltage drop and distortion due to load current is minimized, but “natural” voltage drop and distortion is not reduced (“natural” means already present even if distorting or shifting loads are absent).

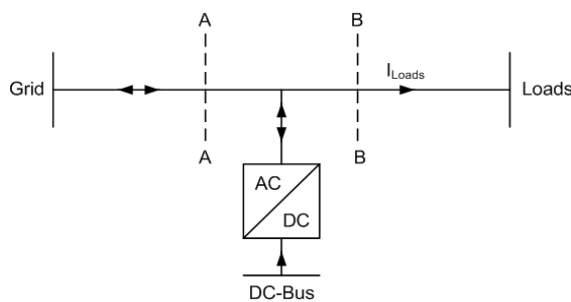

Fig. 1. The basic configuration of active power filter

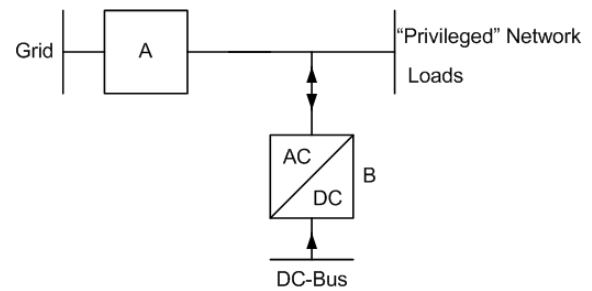

Fig. 2. Improvement of voltage quality by use of decoupling element (A)

In order to improve voltage quality, a decoupling element connected between the grid and the “privileged” network section is mandatory (figure 2). Decoupling element is tagged with A and front – end converter is tagged with B. In the most common solution decoupling element is an inductor and converter is controlled as a voltage source. That way all harmonic currents are absorbed by front – end converter, which also provide the “privileged” network with constant voltage.

It is clear that, should the grid voltage be smaller or larger than the value imposed to the “privileged” network section, a reactive current would be injected to the grid. Active component indispensable to supply loads or injected to the grid is regulated by the mean of the “privileged” network section voltage phase control respect to the grid voltage phase. This topology, improve the voltage quality in the “privileged” network section, but is not able to fix phase of the current exchanged with the grid at a zero value. On the other hand, if converter is well designed and provided with storage elements, this configuration is able to support voltage in the “privileged” network section even if micro-interruptions occur.

If constant voltage against micro-interruptions should be required, a fast switch (usually a static switch) is series-connected to the decoupling element allowing the islanding mode for the “privileged” network section.

One of the possible evolutions of figure 2 configuration consists in replacing the decoupling passive element with an electronic converter. The most common solution uses an inverter controlled as a current source (A) and an inverter controlled to provide the “privileged” network section with the required voltage waveform (B). Should renewable source power be inferior to power required by loads, converter A absorbs from the grid the difference of necessary power. The same reasoning can be carried out for surplus power. For the sake of the two converters well working, control should manage them at the same time; moreover series-connected converter DC-bus and parallel-connected converter DC-bus should be common and renewable sources must be connected to that bus. It is clear that it means the arrangement of a decoupling transformer between AC networks and DC-busses in one converter at least.

The dual case consists in a couple of converters, one of which (the series-connected converter) behaves as a voltage generator, while the parallel-connected converter acts as current generator.

Given that the “privileged” network section supply against grid voltage interruptions is required, configuration in which parallel converter acts as a voltage generator is preferred in applications for the sake of interdiction of control reconfiguration in this case.

From considerations above derives that interconnection of block A of figure 2 between the “privileged” network section and the grid allows on one hand current and voltage waveform improvement, but on the other hand can not engraves on the possible frequency disturbs in the grid.

Figure 3 shows a solution the allows that management of renewable generation together with a “privileged” network section completely independent from the grid. This configuration performs all the following characteristics:

- “privileged” network section stable for what concerns voltage, waveform and frequency;
- complete immunity of the “privileged” network section from micro and macro grid interruptions;
- management of renewable energy is allowed;
- converter connected between the DC-bus and the grid is able to manage sinusoidal current waveform in phase with grid voltage;
- being sensors in section A-A or B-B available, improvement of non-privileged load current is possible and unity power factor absorption is allowed.

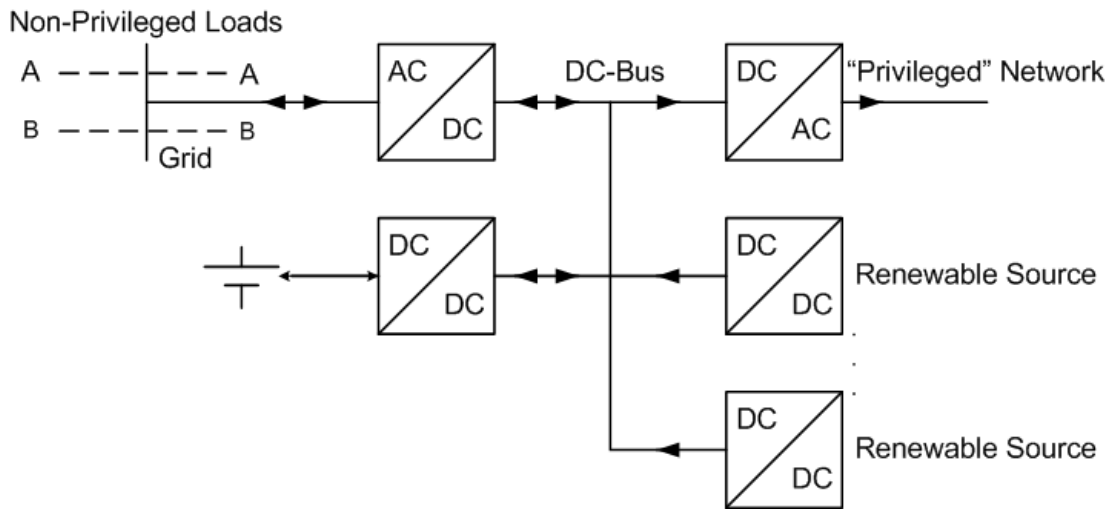

Fig. 3. Management of DR together with a “privileged” network section independent from the grid

As follows from considerations above, interconnection between renewable sources and storage elements by the mean of a DC-bus allows to perform significant economical improvements and an increasing in the efficiency of the whole system.

4.4. Power quality distributed control system

In distribution electrical power network there are various distributed consumers who negatively influence the power quality. In the same network there are many disturbance-sensitive loads.

For the whole system there are set limit values of power quality indices (compatibility levels) [6].

There are also various distributed controlled devices intended for improving power quality, i.e. controlled sources of reactive power (static compensators, idle synchronous motors (SM) with excitation current control), active power filters (APF) etc.

There are also other systems dedicated for specific use which, if designed for these purposes, may perform the functions of fundamental harmonic reactive power compensators, voltage stabilizers and high harmonics parallel active filters. A specific role can be played by AC adjustable speed drives (ASDs) which, as common loads in industrial installations, are of particular significance for the quality improvement. To such load can be applied a VSI inverter, which guarantees a sinusoidal input current in all modes of motor operation and which has an option of generating an additional sinusoidal input current (necessary to supply the motor with the active power required by mechanical part of load) - i.e. the current component according to the reference generated by a central control system (CCS) intended for compensation of other parallel disturbing loads (Fig. 4).

DERs connected into the network may influence power quality (PQ) in a way similar to disturbing loads, introducing disturbances such as voltage variations, harmonics, transients and asymmetry. On the other side they can be an effective mean for compensating such disturbances. It refers, particularly, to the sources of con-

trollable active and reactive power as well as storage systems connected with the supplying networks through inverters.

An effective utilization of DER units, available in the grids now and planned to be installed in the future, needs a management system which would assure suitable control and coordination of operation of individual devices. Developing such a system is one of the tasks necessary to facilitate expansion of electrical power micro grids in the future.

In many publications it has been proved how DER inverters can mitigate PQ disturbances [e.g. 1, 5, 12, 16, 17-19]. Also, the solution for the control system has been presented in [8, 17, 19].

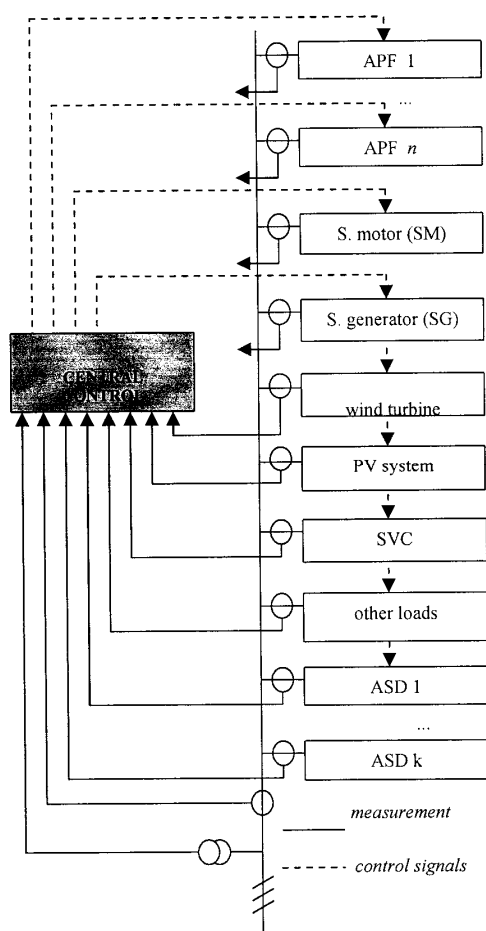

Fig. 4. The concept of a distributed system for electric power quality improvement (ASD - an AC adjustable speed drive, APF - an active power filter)

The control system consists of central power unit (CPU), which manages operation of the whole system, dispersed measuring and interface modules (IM), and controllable devices. In normal operation conditions each device taking part in PQ control generates active and reactive power according to daily operating schedule. Controlling power quality is an additional task the device can perform. It attempts to mitigate power quality disturbances by adjusting the scheduled values of power in accordance with the local comparison of selected power quality characteristic. If the aggregated value of the input signal is outside the local limits then the signal is generated to change power production. In this way power generation schedule is adjusted around the values imposed by the central power unit to keep PQ characteristics within the required limits.

Results of the local controls in a sense are checked by the CPU through global PQ assessment in the whole network in consistence with the requirements of binding standards and regulations. Standardized power quality characteristics are measured and assessed continuously in

each of the three phases at some selected points of the grid (points of common coupling - PCC) in 10-min intervals [19]. Negative assessment of any characteristic shows that its local control is ineffective and then the parameters of local control algorithm (the time intervals of aggregation T_p and the local limits) are revised.

Significant advantages of the developed algorithm are that it is universal and that it

adapts its parameters automatically. Therefore detailed analysis of the electrical grids is not necessary in advance. Furthermore, local power quality control works independently and continuously without requiring triggering by central assessment. Even in the case of a break down of communication between the PCU and a controllable device, the local power quality control is still operational and the operating schedule, already sent to IMs and stored in their local memories, will be executed.

Inverter will require the communications and interface functionality compatible with centrally controlled ancillary services. Communications allow the DER and local loads to interact and operate as part of a larger network of power systems or microgrids. This issue is dealt with in Chapter 3: *Communication and control*.

5. END USERS

The user expects the DER-converter, apart from delivering active power, to play the role of power supply conditioner, i.e. to protect the user from disturbances from supply network and ensure a balanced system of three non-distorted supply voltages with constant rms values. At the same time such converter should reduce the level of disturbances introduced by the user to the supply network and improve the billing power factor. In its most advanced version the DER-converter is therefore expected to be a power supply conditioner that features the UPS function guaranteed by a distributed source.

It can be expected that the end users will be most interested in a large number of additional functionalities and, probably, this will be the largest market segment in the future.

6. EXPECTATIONS FOR STANDARDS

Depending on the primary energy source and on the technology used for the conversion process, the connection of DG units to the grid may also reduce the quality of supply on the network, increasing the electromagnetic compatibility problems. The impact of the phenomena depends largely on the short-circuit power available at the connection point of the DG unit. This may be one of the limiting factors that determine the number and size of DG units that can be connected.

The main topic of this chapter is the issue of converters emission and immunity. It seems that in this field is the strongest need for amendments and modifications to the existing standards.

There is a common idea that there are enough standards issued by IEC 77 to be applied also to generating plants, even though they are originally related to consumer loads. However, the practice shows that some corrections or amendments to these standards should be made because of the DG specificity. Also low frequency emission limits differ in different countries' standards.

6.1. Emission standards

6.1.1. Harmonics

For countries where standards IEC and EN series 61000 are applicable, DG units can in principle be considered as loads. Nevertheless, it seems that because of the DG-inverters specificity there is the need for modifications specified in this standard with respect to:

- *Limit values.* For instance, considering that modern DG inverters are capable of active shaping their output current, the limits for inverters in 61000-3-2 can be lowered.

Additionally they can provide much more than only feeding active power to the grid. In fact they can contribute to the local power quality of the grid due to their inherent active filter capabilities. It seems purposeful to introduce converter classes (e.g. A, B, C, ...) adopting harmonic emission level and/or the converter capability of providing additional functionalities as classification criteria; these functionalities may result from local needs for improvement of voltage quality. This feature of inverters is currently not taken into account in test procedures, whereas it should be.

- *Test methods and procedures to measure current harmonics* of DER-inverters. In many DG-inverters, harmonic currents seem to have a significant dependency on the harmonic voltage content of the AC-system voltage. In this case, the current standard test conditions defined in the IEC standards does not consider real system conditions with respect to the harmonic voltages. According to these standards, tests should be performed with an ideal grid. In result the measured currents are very often comparatively lower than under the condition of real system operation.

The same happens when a large number of generators are connected to the network. For example, large number of inverters on low-voltage feeders can give power quality problems, even if the inverters individually comply with relevant emission standards. As harmonic current pollution of inverters depends on the voltage pollution of the grid, some inverters can produce higher than expected current harmonics, simply calculated from the inverter configuration.

Since some inverters degrade the harmonic content when operated in non-ideal (realistic) grids, this characteristic should be respected in the tests. Tests should be performed on grids with defined harmonics: the simulated grid must not introduce disturbances. An adequate simulation grid must be used during test.

Finally, the harmonic currents differ much under different generation conditions, e.g. there is a great difference between high generation and low generation. The assessment for grid connection of DR-converters shall take also into account of this fact.

The capacitance at the interface of some small generation units (also e.g. cable capacitance of the wind farm internal grid) will results in a shift in resonance frequencies and in the creation of a new harmonic resonances. Resonances in the range between 1 and 2 kHz were measured in a residen-

tial area with large amounts of solar panels. Theoretical considerations showed that resonance frequencies below 1 kHz are unlikely due to small generation unites. When resonance frequencies are already close to one of the lower-order harmonics, the additional capacitance may move the resonance even closer [2].

- *Frequency range 2-150 kHz.* Standards (e.g. IEC 61000-3-2) cover frequencies only up to 2 (2.5) kHz, for any higher frequency currents shall not exceed 0.5% of the device nominal current at fundamental frequency. Currently, when fully controlled semiconductor devices operated at high switching frequencies are commonly used in converters, the operating frequency band should be much more precisely defined. The frequency range from 2 to 150 kHz is not sufficiently covered in international standards. Emission, compatibility and immunity levels should be defined. In the frequency range above 2 kHz, small generation unites with power-electronics interface will be a major source of distortion. Broadband signals are due to individual end-user equipment with active power-factor correction. A general study has indicated that already a very small number of units may results in reasonable limits being exceeded [2].
- *share emission rights between network users.* Taking into account the current approach used by network operators whose purpose is to share emission rights based on subscribed power, very urgently should be developed an appropriate assessment method for emission of working installations. This method should enable on-line determining (without the necessity of disconnecting the installation) the actual contribution of the converter installation to the total voltage distortion at the point of its connection.

6.1.2. Unbalance

Depending on the type of DG units and the voltage level to which they are connected, the connection to the grid may increase the unbalance rate and therefore may affect the quality of supply. Many small-scale distributed or embedded generation unit installed at the customer's site, such as photovoltaic installations, are connected to the LV grid by means of single-phase power electronic inverter units. The connection point has a relatively low short-circuit power level leading to a potentially larger unbalance of the voltage compared with connections at higher voltage level. For systems with the neutral point directly connected to earth, the zero-sequence unbalance ratio can be relevant.

It seems that presently there is no danger of increase in both: the negative- and zero-sequence components unbalance, caused by single-phase DG-inverters. As this situation may change it may occur that in the near future specific limits for distributed generators will be necessary. Assessment of the DG-inverters contribution to total unbalance is not a simple task since unsymmetrical loads are connected to the same network. However, methods to calculate this contribution and, as well, a suitable testing arrangement and simulated testing grid may soon be needed.

6.1.3. Rapid voltage changes

The connection of certain types of DG units to the distribution grid may lead to the occurrence of voltage changes due to switching operations in the DG installation. Currently there is no precise definition (at the international level) of the rapid voltage change and lack of uniformed limit values for this disturbance. There are diverse limit values of the rapid voltage change caused by DG operation (usually start/stop operations of equipment, switching a capacitor bank etc.). For instance: IEC 61000-3-3 - 6%, IEC 61000-2-2 - 3%, and in various countries the limit levels are within the 4-7% range. This variety of limit levels can be expected to be uniformed.

6.1.4. Voltage fluctuations (flicker)

Flicker and voltage fluctuations may need to be specifically considered depending on the operation cycles of the distributed generators. The issue can also be addressed through network requirements in order to control the amount of plant in proportion to the network supply capacity.

The dynamic behaviour of inverter control system and their interactions with upstream voltage regulators and generators can complicate matters considerably. For example, it is possible for output fluctuations of a DER (even smoother ones from solar or wind systems) to cause hunting of an upstream regulator, and, although the DER fluctuations alone may not create visible flicker, the hunting regulator may do it. Thus, flicker can involve factors beyond simply DER starting and stopping or their basic power fluctuations. Dealing with these interactions requires an analysis that is far beyond the ordinary voltage drop calculation performed for generator starting. Identifying and solving these types of flicker problems when they arise can be difficult, and the engineer must have a keen understanding of the interactions between the DER unit and the Area EPS.

An appropriate assessment method for emission of individual working installation should be also urgently developed. This method should enable on-line determining (without the necessity of disconnecting the installation) the actual contribution of the converter installation to the total voltage fluctuation occurring at the point of its connection.

6.1.5. DC Injection

The injection of DC current by distributed generators into distribution networks has received increasing attention due to the importance of converter-based generators. There is a concern that transformer less inverters may inject sufficient current into distribution circuits to cause distribution transformer saturation. The possibility that a DC-component (offset) on voltage or current will appear and flow into the grid has therefore to be considered. Thus there exists a need for determining in IEC

standards both: the limit values and the procedure of measuring DC current component for different types DG-converters⁴.

6.2. Immunity standards⁵

The increasing presence of harmonics and interharmonics superimposed on the grid voltage due to distributed generation has to be taken into account also to guarantee that DG-inverters can continue working properly. Distributed generators should be able to withstand disturbances without false trips of the grid interface protection, over currents or other problems. On the pattern of tests proposed in standard IEC 61000-4-13 similar test for other converters with various power and voltage ratings should be developed.

Practical experience shows that in power electronic systems there exists the problem of mutual adverse impact of converters on each other, long ago known in low-voltage systems. Often the cause is lack of immunity to i.e. commutation notches from other converters. It is worth to give attention to investigation and standardization of such converters immunity.

6.3. Type testing

Today, the utility interconnection requirements, processes and the sitting of DER are far from plug-and-play. Type testing has not yet been accepted by most utilities. In most cases it may only be possible to achieve plug-and-play status for smaller DER units. Larger units will likely continue to be designed, engineered, installed, interconnected, and tested on a site-specific basis. This greatly increases the cost compared with what it would be if the interconnection system was both plug-and-play and pre-certified for installation for particular DER units.

It is anticipated that precise defining of requirements concerning the DER-inverters (DER interconnection equipment in general) leading to interconnection equipment standardization will greatly assist marketplace deployment of DER units by lowering installation costs.

One of the main goals might be to design interconnection equipment sufficiently flexible that they not only meet certifications and receive type testing approval but also can be used in a variety of installation applications. The procedures need to be established that support type testing of specific equipment.

It seems that relatively quickly should/can be defined classes of equipment intended, among other things, to: (a) ancillary services, (b) monitoring (and correction) of power quality problems on the Area EPS feeder, and (c) monitoring and tracking of DER system impacts (on Area EPS operations).

⁴ Like e.g. IEEE 1547 - Standard for interconnecting distributed resources with electric power systems, 2003.

⁵ The issue of the converters immunity to voltage dips, short supply interruptions and frequency variations have not been considered. These issues are dealt with in Chapter 2 *Behaviour under fault conditions*.

7. CONCLUSIONS

Development of a modular universal interconnection architecture with standard functions for power conversion, power conditioning and quality, protection, DER and load controls, communications, ancillary services, and metering is the cornerstone of streamlined DER interconnection.

Component integration is the single most important step in streamlining interconnection. Research is needed to help increase component integration capabilities, with the focus on developing a functional system architecture. This approach is indifferent to equipment specifications and seeks the development of a set of plug-and-play functional components that readily work with one another, regardless of who makes the component. Equipment performance improvements (e.g., increasing the efficiency, surge capacity, and reliability of inverters so they become less expensive to operate and have a mean time to first failure of greater than 10-15 years) and the design of more reliable, smaller, and more durable packaging for combining the interconnection components can hasten interconnection simplification.

For smaller units, complete power electronic subsystems may be assembled as a single unit that can be readily integrated with either a high-speed engine or high-frequency alternator to produce output power in the assume voltage and frequency range. Expanding on this approach, it may be possible to develop a simple plug-and-play interconnection package for smaller DER units. The ideal is a package with two power cords. In this vision, one cord plugs into the DER unit. The other cord has a standard 230-V plug that fits into the Area EPS via a standard 230-V socket.

Similarly, developing standard certification and testing procedures for interconnection components, also inverters, and then deploying and field testing many of the recently commercialised interconnection devices is a needed step in the process.

ACKNOWLEDGEMENTS

The authors would like to thank dr Krzysztof Szubert and dr Krzysztof Marzałkiewicz (The Poznan University of Technology, Poland) dr Antoni Klain and prof. Marian Sobierajski (Wrocław University of Technology, Poland), Marek Samotyj (EPRI, USA), dr Grzegorz Blajszczak (PSE Poland), prof. Jovica V. Milanovic (The University of Manchester, UK) for expressing his opinion on the issues considered in this Report.

BIBLIOGRAPHY

1. Benysek G.: Improvement in the quality of delivery of electrical energy using power electronics systems, Springer 2007.
2. Bollen M.H.J., Yang Y., Hassan F.: Integration of distributed generation in the power system – a power quality approach, 13th International Conference on Harmonics and Quality of Power, Wollongong, Australia, 28 Sep. – 1 Oct. 2008.
3. De Brabandere K.: Voltage and frequency droop control in low voltage grids by distributed generators with inverter front-end, PhD Dissertation, K.U. Leuven, ESAT-ELECTA, ISBN 90-5682-745-6 UDC 621.316, October, 2006; 186 pages.

4. Brochu J.: Interphase power controllers, Second Edition, Polytechnic International Press, Canada 2001.
5. Espie P., Foote C., Burt G., McDonald J., Wasiak I.: Improving Electrical Power Quality Using Distributed Generation: Part 1 – Assessing DG Impact & Capability; 7th International Conference on Electrical Power Quality and Utilisation, 17-19 September 2003, Kraków, Poland
6. EN 50160: Voltage characteristics of electricity supplied by public distribution systems.
7. Friedman N.R.: Distributed energy resources interconnection systems: technology review and research needs, National Renewable Energy Laboratory, Sep. 2002.
8. Klempka R., Hanzelka Z.: Distributed system for power quality improvement. 19th International Conference on Electricity Distribution, CIRED 2007, Vienna, 21-24 May 2007.
9. IEC 50438, IEC 61000-2-2, IEC 61000-3-2, IEC 61000-3-3, IEC 61000-4-13, IEC 61000-4-30, IEC 60038.
10. IEEE P1547
11. Schlabbach J., Gross A.: Harmonic Current Emission of PV-Generation under Controlled voltage Conditions, IEEE 2006.
12. Strzelecki R., Benysek G. (Eds): Power electronics in smart electrical energy networks, Springer 2008.
13. Van den Keybus, Ontwikkeling van een universeel meet- en stuurplatform voor elektrische energie in een geliberaliseerde elektriciteitsmarkt, PhD dissertation, K.U.Leuven, ESAT-ELECTA, ISBN 90-5682-459-7/UDC, December, 2003.
14. Vanthournout K., De Brabandere K., Haesen E., Van den Keybus J., Deconinck G., Belmans R.: Agora: Distributed tertiary control of distributed resources, Proceedings of the 15th Power Systems Computation Conference , 2005 , Liege, Belgium, August 22-26, 2005.
15. Vanthournout K.: A semantic overlay network based robust data-infrastructure, applied to the electric power grid, PhD dissertation, K.U. Leuven, ESAT-ELECTA, April 26, 2006.
16. Wang B.: Challenges in integrating renewable sources into the electric power grid: A power electronics perspective, PSERC Public Tele-seminar April 7, 2009.
17. Wasiak I., Mienski R., Pawelek R., Gburczyk P., Espie P., Burt G.: Improving Electrical Power Quality using Distributed Generation: Part 2 – Case Studies, 7th International Conference on Electrical Power Quality and Utilisation, 17-19 September 2003, Krakow.
18. Wasiak I., Mienski R., Pawełek R.: Technical report on power quality reaction strategies by PoMS, DISPOWER (Distributed Generation with high penetration of renewable energy sources) project ENK5-CT2001-00522, 2005.
19. Wasiak I., Thoma M., Foote C., Mienski R., Pawełek R., Gburczyk P., Burt G.: A Power Quality Management Algorithm for Low-Voltage Grids with Distributed Resources: IEEE Trans. On Power Delivery, Vol. 23, No. 2, 2008.

CHAPTER 2: BEHAVIOUR UNDER FAULT CONDITIONS

ABSTRACT

The “International White Book on the Grid Integration of Static Converters” aims at identifying research needs and standardisation requirements concerning the grid integration of static converters. The present chapter 2 “Behaviour under fault conditions” deals with topics which occur under “not normal operation of the network”. In particular the topics covered are:

- Protection, dynamic grid support, fault ride through
- Micro-Grids
- Functional safety
- Interaction with network protection systems
- System restoration

For each of these topics state of the art, potential problems under a scenario with a high penetration of inverters, expected solutions, and research as well as standardisation requirements are given.

Participants of the Working Group:

Thomas Degner (chapter editor), Dominik Geibel, Nils Schäfer, Wolfram Heckmann, Antonio Notholt-Vergara:

*Fraunhofer IWES, Koenigstor 59, 34119 Kassel, Germany, Phone: 49(561)7294243,
Email: tdegner@iset.uni-kassel.de, dgeibel@iset.uni-kassel.de, nschaefer@iset.uni-kassel.de, wheckmann@iset.uni-kassel.de, anotholt@iset.uni-kassel.de*

Roland Bründlinger: arsenal research, Giefinggasse 2, 1210 Vienna, Austria, Phone: +43(50550)6351, Email: roland.bruendlinger@arsenal.ac.at

*Volker Wachenfeld, SMA Solar Technology AG, Sonnenallee 1, 34266 Niestetal, Germany
Phone: +49(561)95220, volker.wachenfeld@sma.de*

*Norbert Blacha: AEG Power Solutions GmbH, Emil-Siepmann-Str. 32, 59581 Warstein - Belecke, Germany
Phone +49(2902)763324, Email: norbert.blacha@aegps.com*

*Erik de Jong, Roald de Graaff: KEMA, P.O. Box 9035, 6800 ET Arnhem, The Netherlands,
Phone: +31(263)562794, Email: erik.dejong@kema.com, Roald.deGraaff@kema.com*

*Anastassia Krusteva, Petar Nakov: Technical University of Sofia R&DS, 8 Kliment Ochridsky, 1000 Sofia, Bulgaria,
Phone: +359(2)9652548, krusteva@tu-sofia.bg, pnakov@tu-sofia.bg*

*Fernanda Resende: INESC Porto, Rua Dr. Roberto Frias, n° 378, 4200-465 Porto, Portugal,
Phone: +351(222)094000, Email: fresende@inescporto.pt*

*Jörg Jahn: EWE Aktiengesellschaft, Tirpitzstraße 39, 26122 Oldenburg, Germany
Phone: +49(4488)5220140, joerg.jahn@ewe.de*

*Piero Groppelli, Omar Perego, Paolo Mora: CESI RICERCA, via Rubattino, 54, 20134 Milano, Italy,
phone +39.02.3992.5246, piero.groppelli@cesiricerca, paolo.mora@cesiricerca.it, omar.perego@cesiricerca.it*

*Johann Jäger, Timo Keil: Universität Erlangen-Nürnberg, Lehrstuhl für Elektrische Energieversorgung, Cauerstr. 4 Haus 1, 91058 Erlangen, Germany,
Phone: +49(9131)8529513, jaeger@eev.eei.uni-erlangen.de, keil@eev.eei.uni-erlangen.de*

Table of Contents:

1	Protection, Dynamic Grid support and Fault Ride Through	33
2	Micro Grids.....	46
3	Functional Safety	49
4	Interaction with network protection systems	50
5	System restoration	55
6	Appendix 1: DER Protection and Operation – a preliminary analysis	62

1 PROTECTION, DYNAMIC GRID SUPPORT AND FAULT RIDE THROUGH

Authors: Antonio Notholt-Vergara; Roland Bründlinger Erik de Jong; Dominik Geibel

Keywords:

1.1 State of the art

1.1.1 General requirements by current grid interconnection guidelines

Behaviour of DER inverters during voltage and frequency fluctuations is determined by national legal interconnection requirements. Usually, a voltage and frequency band (U-f-curve) wherein the inverter is allowed to operate is given. In spite of a violation with these borders caused by grid instabilities or grid faults the protection device of the inverter has to trip and disconnect the unit.

The protection settings and operating terms differ by country Figure 1 describes by comparison of German and Danish grid code examples.

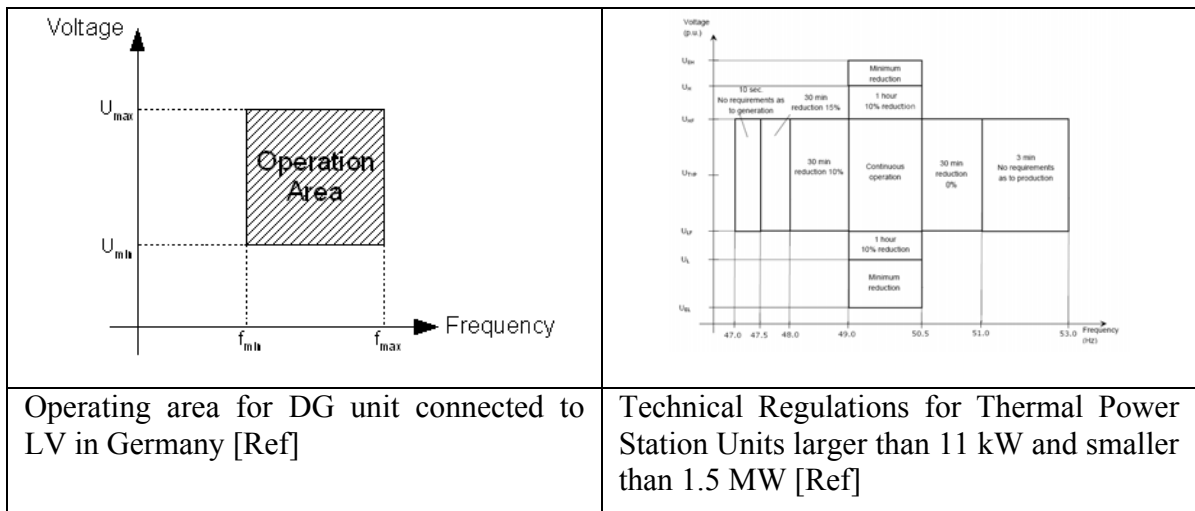

Figure 1: Required behaviour of inverters connected to distribution networks in voltage and frequency

However, until recently, the rules for connecting low-power inverter based distributed generation facilities, to the distribution network did not contemplate any further provisions other than requiring the DER to disconnect within a certain time when grid voltage or frequency left the permissible operating area. Specific requirements e.g. concerning under which conditions a disconnection is not permissible, did not exist for low power LV or MV connections.

Today, given the enormous increase of the share these DER, DSOs and TSOs are more and more concerned by the potential simultaneous loss of large amounts of DER capacity due to short-term voltage or frequency fluctuations resulting from faults in the transmission networks. This concern – first related to the large scale

connection of wind power to the transmission or sub-transmission networks – has led to a number of comprehensive studies for identifying the necessary network measures and operational requirements to meet future challenges [1].

1.1.2 *Fault-Ride-Through*

Among these requirements, the response of the generator in terms of active and reactive power injection into the network and the behaviour of the generation system under fault conditions, commonly known as “Fault Ride Through” capabilities including the ability to stay on-line even at significant decrease of the voltage at the connection point is the key figure. These capabilities as well require the generator to restore its output power to the levels it had before the fault (or voltage dip) in a seamless and fast manner after the fault in the system is cleared.

Fault ride through (FRT) may be defined as the ability of a generator to react in a controlled manner during and after grid faults. Faults are usually perceived by a generator as voltage dips, frequency fluctuations or other disturbances at the device's terminals. A FRT-capable generator must be able to remain connected to the network even when these events occur.

FRT-capable generators are required to inject as much reactive current as possible during the fault and to return back to their scheduled power within a certain period of time (usually some seconds).

FRT requirements have recently been included in several grid codes like the Irish Electrical Code [2], the Spanish code and the German Grid Code [3]. These codes however contemplates only the requirements for generation to be connected to the transmission network. Since most wind parks are connected to this network level, the new code solves the current problematic regarding FRT.

Although FRT capabilities are a state-of-the-art prerequisite for the connection of wind parks to the transmission network, it has not yet been required for smaller generators until the beginning of 2009⁶.

This regulation does not apply, however, to generation facilities connected to the low voltage distribution networks where currently other codes apply. Therefore, under current regulations, any drop in the voltage below certain limits should lead to the disconnection of the generator *within* a certain period of time [4]. Examples of such regulations are the VDE 0126-1-1:2006 (Germany) and the IEEE 1547/UL 1741 (United States). Figure 2 compares different current standards for generators connected to the Low Voltage Grid and compares them with the FRT requirements for new Generation to be connected in the high voltage network (German Transmission Code 2007).

⁶ The new german Code for the connection of generators in medium voltage networks will come into effect on 1. 1. 2009.

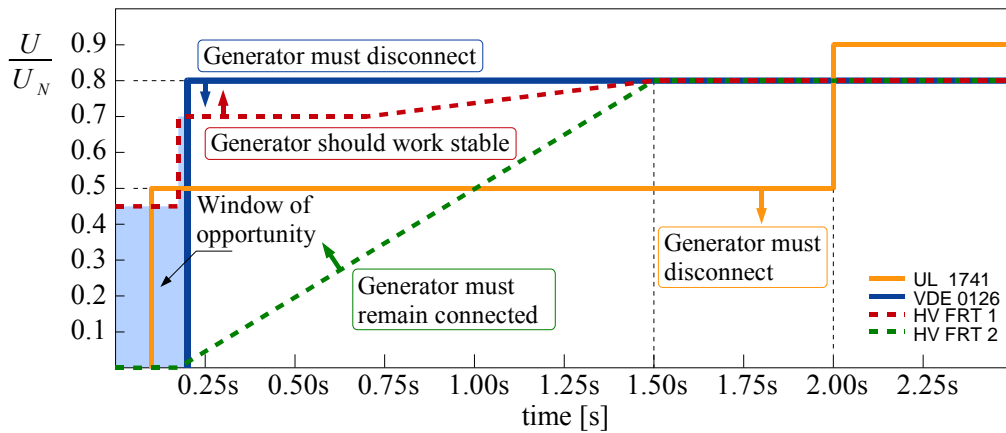

Figure 2. Several requirements regarding disconnection by voltage dips

1.1.3 FRT as it applies to DER inverters

Recent laboratory tests of small-scale grid-connected PV inverters have shown, that there are considerable deficits with respect to the capabilities of the devices to ride through transient voltage dips [4].

As indicated by the measured voltage sensitivity curves (Figure 3), which represent the border between different performance criteria (e.g. Inverter remains connected and feeds power vs. inverter disconnects), the large majority of currently available devices have a very high sensitivity towards grid voltage disturbances. Actually, only one out of the 13 tested devices was able to continue feeding current on a voltage dip with a remaining voltage of less than 30%, which would be required e.g. by the new draft of the German MV grid code.

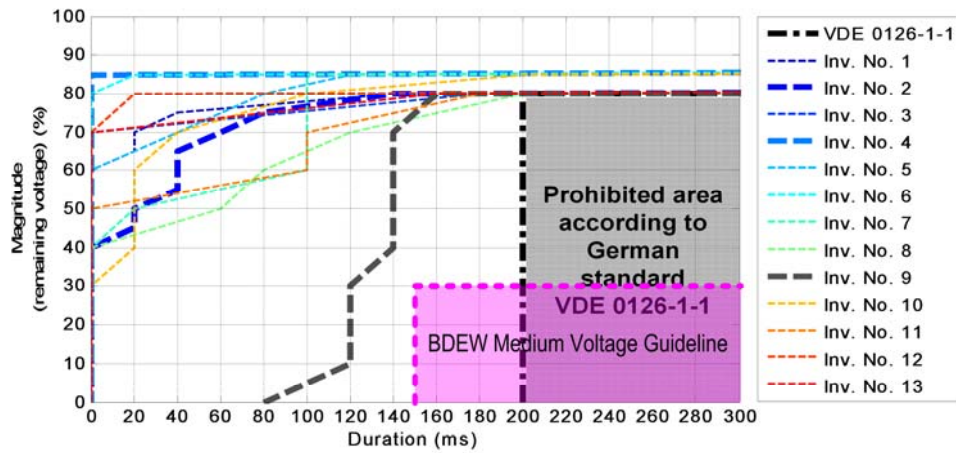

Figure 3: Measured voltage tolerance curves of 13 state-of-the-art PV inverters

In detail, the conclusions drawn from the tests were that the current problems can be mainly related to a lack of adequate requirements and the resulting lack of awareness during the development of the inverters. In this context the network interface protection (usually voltage/frequency), as well as the strategy and the dynamics of the inverter control are the most critical parts of the whole inverter.

However, few devices with high immunity indicate that FRT can be realized by adequate hardware and control design without additional costs.

1.2 Potential problems (>20% inverter penetration scenario)

The above described conflict of interest between standards regarding FRT may result in system instabilities as it may be seen on Figure 4. On the left side of the figure, a system in which its active power flows are in equilibrium can be seen. Assume this system has a considerable proportion of Distributed Generation on several of its low voltage nodes.

When a fault occurs –such as depicted on the right hand side of the figure – and the generators do not *ride* through the fault, they would disconnect from the line even if the fault is cleared. This would provoke an unbalance in the power flow which, under normal circumstances, should not have occurred. If the proportion of the disconnected generator reaches a significant level, as in this case, it could threaten the stability of the grid.

The current state of the art could bring up a stability issue if these types of low-power decentralized generators begin to increment their share of the total electricity produced.

To prevent this instability, the utility company would need to increase its reserve power over the standard values to compensate for an eventual disconnection of the distributed generation units. This is of course not economically desirable and difficult to implement as an accurate assessment of DG resources either installed or in operation cannot be easily achieved. The Utility company sees only either a consumption or a generation at the nodes but cannot assess --at the present time-- which is the actual load nor generation as they add up to give a net power flow at the distribution node.

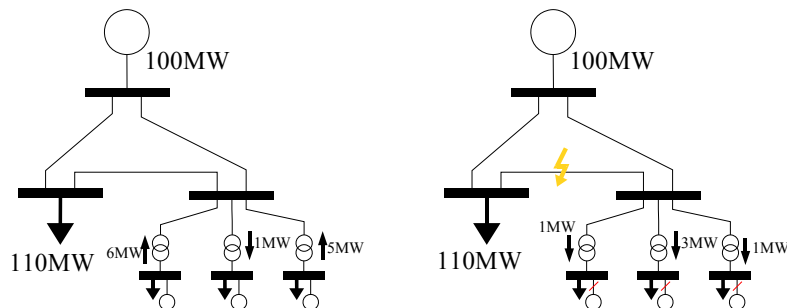

Figure 4. Several requirements regarding disconnection by voltage dips

Another problem of not implementing FRT capabilities in generators has to do with the voltage support process of the system during the fault.

1.3 Vision 2020 (...Solutions):

Under the high penetration scenario of inverter based DER described above, potential problems will arise in case of an uncoordinated behaviour of inverters during voltage and frequency deviations. This might eventually lead to a simultaneous shutdown of significant parts of renewable generation units which can result in grid instability or even black out in the affected part of the network.

Therefore it will be crucial that all generators react in a clearly defined way to avoid transient instabilities. Technically, this will particularly concern the behaviour of inverters during voltage and frequency deviations.

The following general requirements for the behaviour of the inverters during disturbances, caused by faults in the network (same network level or higher level) have to be fulfilled in that context:

1. Not to disconnect in case of faults in the network (FRT).
2. Support the grid voltage in case of faults by injection of reactive power during the fault (voltage support)
3. Immediate return to normal operation conditions after clearance of the fault (Recovery)

From the inverter design point of view, these requirements would imply that:

1. The *interface protection* shall be designed in a way to have a clearly defined window of operation resulting in a defined trip – no trip behaviour. The interface protection should be immune towards others disturbances superposed on the grid voltage, which might occur during a fault (e.g. harmonics, phase jumps,...)
2. The hardware topology of the inverter shall be designed to be capable of temporarily supplying active and reactive currents on low grid voltages (e.g. <30% of the nominal voltage) during a defined period of time.
3. The internal control strategy of the inverter shall be designed to be capable of supplying defined active and reactive currents during faults (voltage dips). It shall be possible to specify the detailed characteristics (e.g. amount of reactive current dependent on the actual grid voltage during the fault).

Further important steps towards an integration of inverters for grid support can be made by active power limitation, reactive power supply, voltage control or FRT capabilities through inverters in coming up interconnection guidelines.

1.4 Research needs

An active integration of inverter based DER into the network operation as drafted in the previous section requires not only dedicated and appropriate guidelines for the inverters' capabilities itself. Above all, the network operation practises will need to be adopted to allow an active role of the generators.

As both items have not been appropriately elaborated yet, the required changes will bring up a broad variety of issues, which have to be covered by targeted research.

The following items highlight some of the key research needs which have to be addressed in this context:

- *Network level specific issues:* At different network levels (MV/LV) grid-support by DER inverters requires adapted solutions. Requirements and capabilities which are e.g. appropriate for generators connected to MV might on the other hand not be practical for LV connections. Moreover, guidelines, methods and practises for the practical and coordinated settings of the grid interface protection, FRT and active control have to be defined as the actual settings will differ depending on the local network conditions. By targeted research, the related issues which have rarely been addressed up to now will have to be investigated in detail.
- *Inverter technology issues:* While generic inverter topologies can be easily adapted to allow FRT and extended control (e.g. active/reactive power) capabilities, a multitude of the currently used sophisticated inverter topologies have been solely optimised to maximise the inverters conversion efficiency – which used to be the main objective to maximise economic benefits. As a consequence, some of these topologies are not capable of supplying reactive power or operate during transient voltage fluctuations. By R&D these technical issues have to be investigated.
- *Inverter and plant economy issues:* New regulations and new requirements for FRT and active control thus represent a challenge for the development, not only in technical terms. Moreover, in this context also the monetary value of the grid support provided by DER vs. the costs caused by additional losses becomes of vital importance, as the added flexibility required from the DER will implicate higher losses, additional equipment costs and thus reduced economy for the plant operator. To compensate for this models and schemes have to be developed. When it comes to the guidelines, a trade off between flexibility/capabilities and high conversion efficiency has to be found by R&D.
- *DER interface protection implementation issues:* Regarding integrated interface protection functionalities, which are commonly integrated into small scale inverters (usually in the range up to several 10 kVA), the question arises if it is feasible to implement even complex protective functions which might be required by the grid codes. The functional safety of the

protective functions is a further issue in this context. Hence a trade-off between necessary functionalities and the capabilities is to be found.

- *Grid protection issues:* To ensure the safe and reliable operation of the grid even under a high DER penetration scenario, the coordination of the different protection schemes and devices – in the grid as well as at the DER – is one of the key requirements. Uncoordinated behaviour can cause additional conventional primary control what results in high costs and inefficiency. In this context, constraints such as the adequate function of grid protection devices even under low short circuit current conditions have to be considered and need to be investigated. New network planning methods and protection schemes will be needed.

1.5 Standardisation requirements:

In the field of DER, standardisation plays a key role in the future development and realisation of the DER based Smart Grids. Today this issue is covered by a variety of national grid codes, interconnection guidelines and national standards which create a lot of complexity and in many cases provide only limited guidance to equipment manufacturers as well as network operators. The current lack of harmonisation of the requirements in Europe as well as on the international level further complicates the situation.

Especially in the field of protection, dynamic grid support and fault-ride-through, harmonised and appropriate standards dedicated to the application will be necessary to achieve the objectives set in the vision scenario drafted above.

In detail the objectives to be fulfilled by these standards include:

- Harmonisation of grid connection codes in European countries
- Scenario/application based requirements for
 - Control (output current, power factor, short circuit current...)
 - Immunity (“when to remain connected”)
 - Protection (“when to trip”)
- Equipment classification based on
 - Network level
 - Capabilities and limitations
 - Application range

With respect to DER inverters, it is crucial that the standards reflect the characteristics, capabilities as well as the limitations of inverter based generation. While e.g. rotating generators show a “typical” behaviour, which can only be changed in a rather limited way by equipment design, an inverter may be designed to provide an almost arbitrary behaviour. To make use of this flexibility, detailed and clearly defined requirements are needed. Cornerstones of these standardisation requirements can be divided into several tasks (cp. Figure 5).

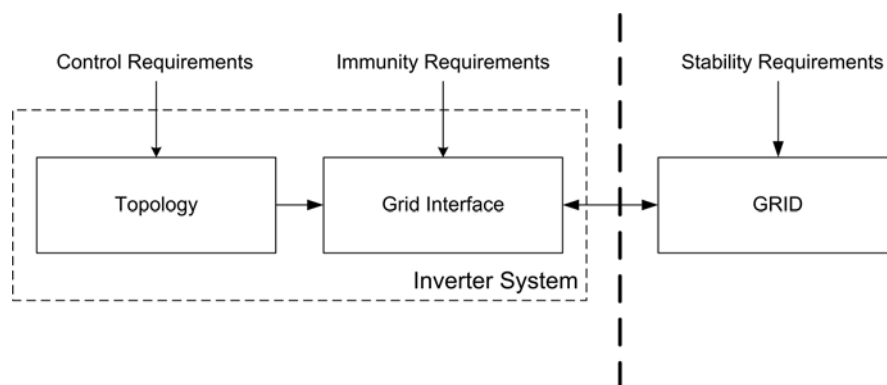

Figure 5: Splitting of standardisation requirements into several tasks

Immunity and stability requirements:

DER inverter protection and network protection have to be coordinated in an appropriate way to support grid stability. Therefore an adequate protection design based on scenario with high DER inverter penetration has to be applied. In this context especially integration of new challenges due to characteristics of DER inverters has to be remarked:

- Limited short circuit power in-feed of inverters
- Adaptive protection concepts due to fluctuating power feed-in of DER units

Control Requirements:

- Dynamic Voltage Control (Reactive power injection)

It has to be clearly defined how the DER inverter should react in case of a grid fault. Based on a voltage-time curve this behaviour could be described as shown in Figure 6. Proposed behaviour could be categorised as following:

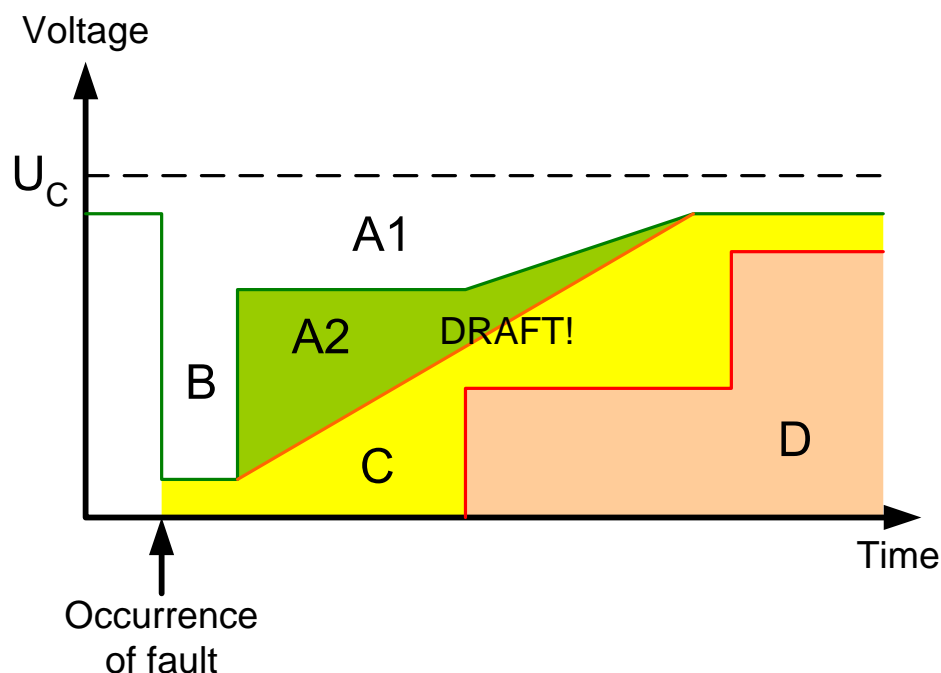

Figure 6: Proposal for the specification of FRT and protection requirements for inverters

A1 Normal Operation

A2 Supply of a defined current (active or reactive)

- B No disconnection but undefined current feed-in
- C Inverter may disconnect where protection behaviour and current feed-in are not defined
- D Inverter has to disconnect to fulfil protection requirements

Need of standardisation requirements is to define the voltage and time values for the several operating modes during a grid fault.

- Active power limitation

In case of over-frequency active power limitation of DER units could help stabilising the grid. A possibility for applying this over-frequency behaviour to DER units can be arranged as shown in Figure 7 using defined parameters for frequency and slope of active power reduction.

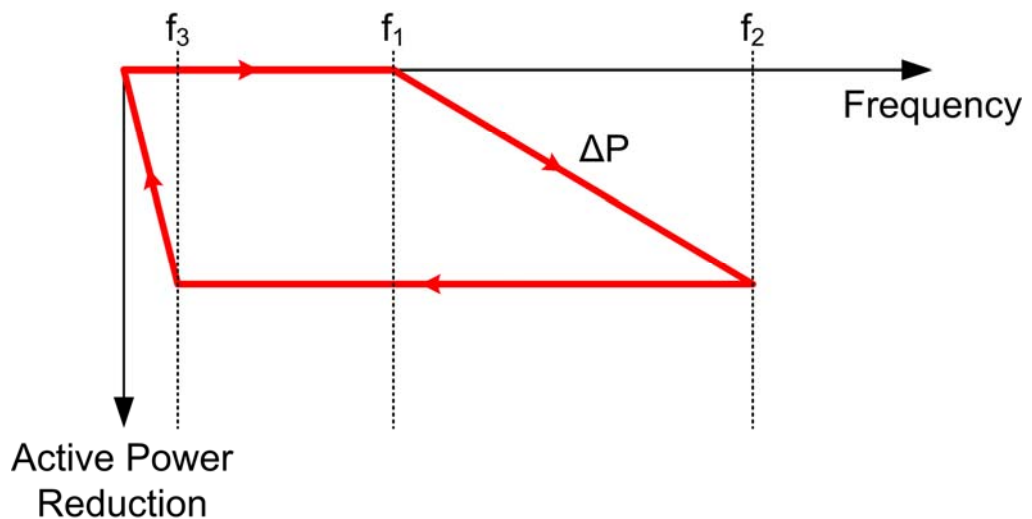

Figure 7: Proposal for specification of FRT and protection requirements for inverters

- f_1 Start-frequency of active power reduction
- f_2 Switch off frequency due to protection requirements of the DER unit
- f_3 Frequency of re-increasing active power
- ΔP Slope of active power reduction

Need of standardisation is to define appropriate parameters to assure a comparable behaviour of DER inverters in case of over-frequency.

- Voltage Control (Reactive power injection)

Beside the injection of reactive power during a grid fault also under normal operation conditions injection of reactive power for voltage control can be useful.

Standardisation needs are identified for the ranges of reactive power DER units have to provide and the way how the amount is communicated to the DER unit.

Testing requirements:

For these new kind of DER inverter behaviour testing procedures and/or tools for simulating inverter behaviour in grids have to be developed and compared e.g. with Round-Robin-Tests for assuring a comparable behaviour of DER inverters.

1.6 Literature

- [1] I. Erlich and U. Bachmann, "Grid code requirements concerning connection and operation of wind turbines in Germany," Power Engineering Society General Meeting IEEE June 12-16, vol. 2, pp. 2230 – 2234, 2005.
- [2] I. Board, "Discussion document for the review of requirements for wind turbine generators under system fault conditions, commonly referred as fault ride through," Irish Electricity Supply Board, Tech. Rep., Feb. 2004, online. [Online]. Available: <http://www.eirgrid.com/EirGridProtal/>
- [3] VDN, „TransmissionCode 2007. Netz- und Systemregeln der deutschen Übertragungsnetzbetreiber“, Verband der Netzbetreiber - VDN – e.V. beim VDEW, Version 1.1, August 2007.
- [4] B. Bletterie, R. Bründlinger, and H. Fechner, "Sensitivity of photovoltaic inverters to voltage sags – test results for a set of commercial products," in Proceedings of the 18th International Conference on Electricity Distribution, Turin, 6-9 June 2005.
- [5] BDEW, „Technische Richtlinie Erzeugungsanlagen am Mittelspannungsnetz - Richtlinie für Anschluss und Parallelbetrieb von Erzeugungsanlagen am Mittelspannungsnetz“, BDEW Bundesverband der Energie- und Wasserwirtschaft e. V., June 2008,

2 MICRO GRIDS

Author: Norbert Blacha

Keywords: (micro grid, product standard, power quality, availability, supply safety, complex structure, communication, sophisticated)

2.1 State of the art:

Several blackouts in North America and Europe underlined the dependence on its imperfect power grid(s). Analyses conducted in the aftermath have focused almost exclusively on ways to perfect the grid, presuming highly developed economies require flawless power at whatever cost.

As our impressive and successful modern grids have evolved, the expectation that they can and should be uniformly close to perfect has led to a system of critically interdependent services vulnerable to grid failure. Heightened security concerns and the penetration of electronics into myriad aspects of everyday life are deepening this vulnerability.

Some less explored solutions to grid vulnerability are: (1) providing heterogeneous power quality and reliability (PQR), so that quality provided better matches quality needed; (2) hardening socio-technical systems to an inevitably imperfect grid; or (3) providing power sources locally to sensitive loads. Considering alternatives is vital, as the technologically advanced economies struggle to meet inexorably growing electricity usage and push the limits of affordable power quality.

While dependency on the grid has intensified, smaller generation using a diverse mix of technologies, usually collectively called distributed energy resources (DER), has emerged as increasingly competitive with large remote central station generation. Many of these sources generate power directly, e.g. photovoltaic modules (PV), while others involve on-site energy conversion. Waste heat utilization delivers one of the key advantages of small scale generation involving conversion, e.g. from reciprocating engines, fuel cells, or micro turbines. This heat can be productively applied to many end-uses, but when used for cooling, using absorption cycles, it can be particularly valuable because it displaces high priced electricity and simultaneously lowers the peak power requirement of the site, i.e. both saves expensive on-peak electricity and downsizes other system requirements.

A rich and growing literature explores the case for supplementing our existing power system by smaller scale localized generation closer to loads. The purpose here is not to provide a comprehensive survey of DER benefits, although a brief survey is offered. Rather, just two issues are addressed: (1) the inability of our existing power system to provide for growing electricity use together with the inappropriateness of providing for the most demanding end-uses by a universal standard PQR, and (2) the potential benefits provided by application of combined heat

and power systems in micro grids. Specific micro grid concept are under development world wide.

2.2 Potential problems:

Micro grids are normally complex and complicated based on new and sophisticated technologies respectively components and especially sophisticated communication means. Different components from different industries will be integrated in one common structure to fulfil the job of most possible delivery of high power quality to the load, including for sensitive and critical loads with nonlinear and unbalanced characteristics. Therefore different certification and testing measures are required for the validation of product quality and compliance with all adequate standards, e.g. IEEE 1547 for Interconnecting System Requirements , IEEE 1547.1 for Interconnecting System Testing and UL 1741 for Interconnecting Equipment, IEC 62040 for static UPS components , IEC 62310 for Static Transfer Switches (STS) etc..

2.3 Vision 2020 (...Solutions):

Distribution systems of the future will be safe and economic. This means the following properties respectively performance of future micro grids:

- High Safety
- High Power quality
- Improved outage mitigation capabilities
- Increased profit for distribution company
- Increased customer service
- High availability arranged by higher degrees of redundancies and MTBF
- Intelligent components like inverters, generators , STS, UPS, storage, BEMI, supervisory computers etc. cross-linked by powerful communication means

2.4 Standardisation requirements:

The different components which are parts of micro grids come partly more or less often from different branches of electro industry with different cultures, traditions, testing rules and last but not least different standards for similar things.

Therefore we have a need of standard harmonization. Especially important is the harmonization of product safety aspects. Therefore it is recommended to use or to create a common referenced document (RD) for similar or equal product safety aspects concerned with micro grid components.

In addition we need the clarification of common standard base for EMI and EMC requirements.

Last but not least a new standard for micro grids which deals with the test and performance issues of a complete micro grid is required. This standard could have a section to handle the integrated system behaviours including interconnection demands and could have additional sections which could be based on present product standards of used components including extensions defining specific micro grids properties if required or recommended.

Conclusion:

It is recommended to create a **product standard for micro grids** containing three parts: IEC xxxyy – 1 “Product Safety of Micro Grids”

IEC xxxyy – 2 “EMC and EMI Requirements of Micro Grids”

IEC xxxyy – 3 “Test and Performance of Micro Grids”

2.5 Literature

- [1] C. Marnay, O. Bailey; „The CERTS Micro grid and the Future of the Macro grid“ ; ACEEE 2004 Summer Study on Energy Efficiency in Buildings, Asilomar Conference Center, Pacific Grove CA, 22-27 Aug 2004

3 FUNCTIONAL SAFTEY

Authors: Norbert Blacha

Keywords: functional safety, abnormal test

3.1 State of the art:

High demands for functional safety are established in the power plant industry, especially in nuclear power plants based on serious validation and certification processes. The functional safety is also established in different products of power supply industry because power supplies are an essential part of the safety concept of power plants, communication networks, hospitals, air traffic, chemical industry, oil and gas etc. Product standards give the frame for the implementation and the verification of functional safety. Several standards contain sections about functional safety issues.

3.2 Potential problems:

We can state misunderstood what is meant with functional safety. Normally functional safety does not mean product safety e.g. in terms of isolation distances, lightning protection or EMI requirements defined in generic standards or are related to the safety product standards or EMC/EMI product standards. These are basic requirements which have to be fulfilled normally.

Functional safety means the immunity against unforeseen events or abnormal conditions related to a safety function. A safety function can be for example a micro grid, because it contains sensitive loads like a chemical process e.g. which need a high supply safety. It is an add-on for safety, availability and robustness for a system.

3.3 Vision 2020 (...Solutions):

The functional safety will be more and more an issue for components and systems of DER applications and will be defined in product standards of components of DER and DER-systems like a micro grid e.g.

3.4 Standardisation requirements:

The product standards for components like inverter and complex systems like micro grids should be open for extensions related to functional safety requirements.

4 INTERACTION WITH NETWORK PROTECTION SYSTEMS

Authors: Timo Keil, Nils Schäfer, Johann Jäger

Keywords: Intermediate infeeds, over-/underreach effect, direction determination, nominal rated short circuit current (scc), pick-up

The field of considerations of this subchapter are the influences of grid inverters on traditional **network protection systems** and upcoming visions as well as standardisation requirements. Network protection systems are defined as to contain all functions which lead to operation of power switches or circuit breakers as an initiated corrective action due to detected abnormal power system conditions, to return the power system to its normal state, while all actions which change the operating state (voltages, currents, power flows) of the power system without changing its network topology and/or structure are out of consideration.

According to that line protection, transformer protection and busbar protection and along with these the most common relaying principles overcurrent detection, differential comparison, distance measurement and automatic reclosure are considered. In this regard machine protection (integrated protection of grid inverter) and disconnecting elements (refer to sub-chapter 1) are excluded.

4.1 State of the art:

The state-of-the-art protection on radial distribution feeders is the inverse definite minimum time (IDMT) overcurrent relay and the definite time overcurrent (DTOC) relay. Distance protection however is implemented in meshed distribution systems, to maintain selectivity with fast fault clearing times.

In overhead line networks, automatic reclosure is generally practised. On overhead lines most faults are of a transient nature and disappear when the infeed is switched off for a short period (dead-time). After fault clearance the line can be returned to service. Usually the three-phase short dead-time (rapid auto-reclosure, $t_{\text{dead}} = 0.3 - 0.5\text{s}$) is used, sometimes in addition with a three-phase long dead-time (delayed auto-reclosure).

Besides, in cable networks differential protection is implemented for short and/or important lines.

Based on less grid inverter introduced in number and capacity up to now (and dispersed generation in general) and pursuing an “early disconnection at first sign of trouble”-philosophy, there are hardly influences of grid inverters on the traditional protection system. In future DG-networks early disconnection might not be the best approach (refer to ancillary services). Continuity of supply should be maintained

through fault-ride-through criteria. Then a dominant application of grid inverter in distribution systems is challenging the following potential problems on network protection systems:

- intermediate infeed and error of measurement
- intermediate infeed with over-/underexcited power factor
- nominal ranged short-circuit current and hindered discrimination of load and fault case
- bidirectional power flow and sympathetic tripping
- deliberate islanding
- automatic reclosure
- unknown and undetermined grid inverter behaviour during fault and voltage recovery time

4.2 Potential problems:

Intermediate infeed

In the following the fundamental functioning of intermediate infeeds influencing the measurement elements of protection devices will be discussed on the basis of the distance measurement element.

The current from an intermediate infeed (grid inverter e.g.) introduces an additional voltage in the short-circuit loop. This influences the measured voltage at the relay location, while the reason for the additional voltage, the current from the intermediate infeed, is incapable of measurement. The distance measurement is therefore afflicted with an error ΔZ (refer to Fig. 5.1).

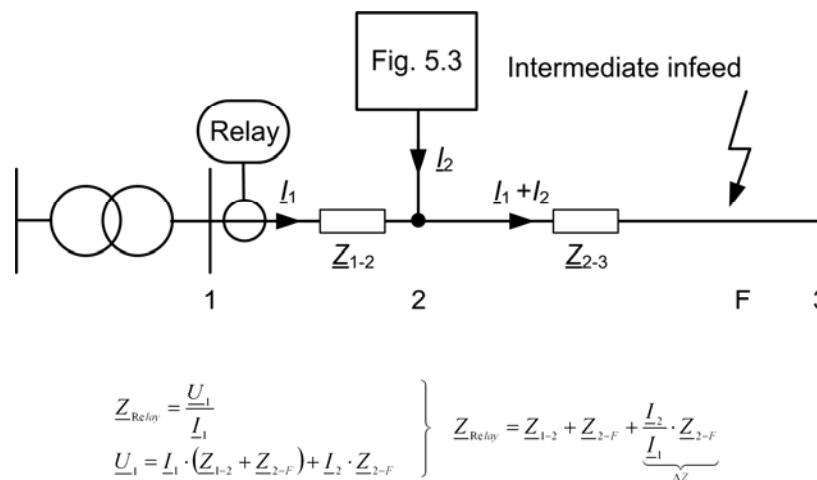

Fig. 5.1 Intermediate infeed

It can be shown that the measurement error of intermediate, voltage source infeeds (synchronous generator, induction generator) is positive leading to a greater seen distance and the relay may only trip in a higher zone (underreach, refer to Fig. 5.2a, Eq. 5.1).

$$Z_{Relay} = Z_{1-2} + Z_{2-F} + \underbrace{Z_{2-F} \cdot \frac{Z_{source} + Z_{1-2}}{Z_{DG}}}_{\Delta Z} \quad (\text{Eq. 5.1})$$

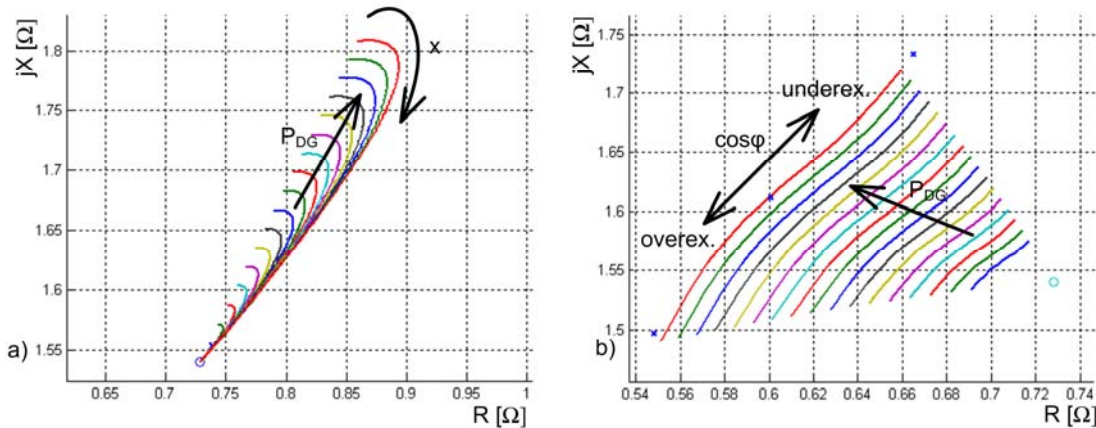

Fig. 5.2 influence of intermediate infeeds on distance measurement a) voltage source infeeds, b) current source infeeds (grid inverter)

High switching frequency grid inverters can guarantee any set of three phase current and voltage waveforms and therefore seem to be most suitable for ancillary services. In theory the power factor can be adjusted on demand, e.g. for voltage control (reactive power management, STATCOM).

They behave as current sources during normal and abnormal situations. Fig. 5.2b shows the sensed distance with an infeeding grid inverter. The grid inverter is a constant DC-bus-voltage-controlled inverter (blue) with a current regulator (red) and specified (re)active power infeed or power factor respectively (refer to Fig. 5.3).

The behaviour as a current source makes negative ΔZ possible leading to a shorter seen distance and the relay may overreach which must be implicitly avoided.

Result 1: With practical implementation of protection devices, consideration must be given to this influencing quantity. This requires a determined and reliable behaviour of grid inverter during fault and voltage recovery time.

Result 2: Because grid inverter can generate any set of three phase current and voltage waveforms with any phase displacement angle, overreach can occur. This requires working areas for the phase displacement angle during fault and voltage recovery time to prevent overreaching.

Deliberate islanding

In islanded networks the influencing quantity of intermediate infeeds is more distinctive. This shows Eq. 5.1: in islanded networks the source impedance Z_{source} is relatively high and leads to a dominant underreach effect and can even lead to false pickup.

Result 5: In contrast to result 3 the absolute value of the grid inverter short-circuit current must be limited.

Automatic reclosure

Care must be taken to ensure that the decentralised grid inverter is decoupled on time during a fault on the feeder. The infeed to the main feeder during auto-reclosure dead-time would otherwise prevent the extinguishing of the arc if the current remains above the critical extinguish threshold.

Result 6: The decentralised grid inverter must therefore be equipped with appropriate decoupling functions for this aspect.

4.3 Vision 2020 (...Solutions):

New relays, new protection-algorithms, enhanced, standardized communication functionality, optimisation methods for settings.

Grid inverters which detect fault conditions (loss-of-mains protection, → automatic reclosure) and deliver an adapted, determined short-circuit current (magnitude and phase displacement angle) being processed by protection relays reliably.

4.4 Standardisation requirements:

Grid inverters have to deliver a determined short-circuit current. Standardisation requirements are necessary to define working areas of the phase displacement angle and the absolute current value during fault and voltage recovery. Quantitative conclusions can be given after detailed analyses of network and protection as one system unit.

The automatic reclosure must be considered for decoupling-schemes.

5 SYSTEM RESTORATION

Authors: Wolfram Heckmann, Fernanda Resende, Jörg Jahn

Keywords: Black start capability, load/ storage/ generation-management, synchronisation, grid forming unit(s), bidirectional communications, islanding

5.1 State of the art:

The system restoration procedure is a set of actions prepared in advance of a large scale collapse of the system, the so-called blackout. According to the definition of the UCTE handbook a blackout means that significant parts of the electrical grid are out of voltage, with total or partial disruption of consumption supply [1]. Following a general blackout, the system normal operation has to be restored as soon as possible, being the main objective the maximization of restored loads within the minimum elapsed time, satisfying also the required security and operating conditions.

Conventional power system restoration procedures are usually developed before any major disturbance occurs based on results obtained from different numerical simulations. In addition heuristic approaches, which reflect human operators' experience to deal with the problem, are adopted. Furthermore, the size and specific characteristics of each power system precludes the definition of a universal methodology [2]. Therefore, restoration plans are usually defined step by step, based on predefined guidelines and operating procedures, exploiting sometimes decision support tools to assist system operators [3][4].

Network restoration procedures are focused on the plant preparation for restart, network energisation and system rebuilding. However, depending on system characteristics, the restoration procedure must follow either a strategy of energizing the bulk network, creating thus the global system skeleton, before synchronizing most of the generators and load pick-up or a strategy of restoring islands first [5]. In this case, when at least two islands are restored, they are usually synchronized in order to form a new one and so forth, being the load picked-up for the whole system. Both strategies are top-down procedures regarding the voltage levels of the system.

Two common characteristics of both strategies are the choice of the initial power source – the Black Start (BS) unit – and the power system control during the restoration procedure. BS units are usually gas or hydraulic turbines because of their ability to start up autonomously and to be coupled on the network in a short time. Concerning the control during the restoration procedure, it is usually divided into two global stages: I) the production restarting and network integration, wherein the main control concerns are about unit restart, voltage profile, switching operations and prime movers response to a sudden load pickup; II) the stage of load supply, where more attention is paid to the real and reactive power balance, overloads and load uncertainty. However the voltages must be kept within acceptable limits dur-

ing the load supply stage and the power balance must be respected during the first restoration stage.

The network restoration is defined as a system service of the transmission level. Accordingly BS units are usually connected to the transmission grid. If BS units are connected to the distribution grid special agreements between the operator of the distribution network and the transmission network are necessary [6].

Although Distributed Generation (DG) has been increasing significantly in recent years, there is a little work on the identification of its possible contribution for power systems restoration. The general policies for integration of DG in electrical power systems is based on the principle that DG should not jeopardize the power system to which it is connected and it should be quickly disconnected following any disturbance. Additionally, it is only reconnected when distribution circuits are energized and present stable values of both voltage and frequency.

It would be possible to develop a bidirectional network restoration strategy that will run simultaneously in both the transmission and distribution systems. Such a strategy will exploit the conventional power system restoration strategies in the upstream transmission level, while the energisation of islands by means of DG units will allow expanding service restoration at the downstream distribution level based on the availability of DG units with BS capability. The synchronisation of these energised islands follows afterwards. The coordination between the upstream and downstream restoration will allow a better service continuity, increasing the amount of restored load and shortening the electrical power restoration times [7][8]. So, the entire power system restoration procedure can then exploit a simultaneous bidirectional approach: a conventional top-down philosophy, starting from large plants restart and transmission energisation and simultaneously a bottom-up strategy, starting from the distribution side and exploiting DG units and micro-generation capabilities.

5.2 Potential problems (>20% inverter penetration scenario)

Today DER do not contribute actively to network restoration procedures. With significant higher share of DER of the entire energy production the relation of the back-up capacity of bulk power generation units to their energy production will become more adverse. Thus the costs for the system service “black start capability” or “network restoration” respectively will increase. Apart from this problem DER may contribute to a faster network restoration than today.

5.3 Vision 2020

The system restoration procedure will change from the current top-down strategy to a bidirectional strategy where the power system is re-energized from the top by central power plants, following conventional system restoration strategies, and from the bottom by DER forming MV islands and MG in the distribution system. The down time of the electrical supply of the consumers will be significantly reduced. For this purpose MGs can play a key role.

A micro grid is defined as a cluster of small DG units, loads and storage devices connected to the LV grid. It can be operated in grid connected mode working in a coordinated way with the DMS and autonomously in islanded mode. In addition, MGs have the ability of ride-through between the two operating modes.

MGs are characterized as inverter interfaced LV grids and it will not be expectable to find conventional synchronous machines, which are liable for voltage and frequency control in conventional power systems. The absence of synchronous machines requires that power balance during transients should be provided by energy storage devices (batteries and flywheels). In addition MG static converters should be responsible for controlling voltage and frequency during islanded operation. According to [7] two situations must be distinguished regarding storage needs for frequency control: One corresponds to the MG main storage and the other regards the capability of some voltage source inverters for providing energy stored in their dc links. Combining the inverter control techniques two main strategies are possible for MG operation in islanded mode [7]: I) Single Master Operation (SMO), when a single voltage source inverter is used to provide system voltage and frequency references; II) Multi Master Operation (MMO), when two or more inverters are operated as voltage source. Eventually other power controlled inverters may also coexist.

Following a general system blackout due to a fault occurrence outside the MG, not affecting seriously its equipments, it can provide a fast service restoration for LV consumers. Following the system collapse MG loads and generators are disconnected from the LV grid as well as the LV/MV transformer. Then, DG units with black start capability will start up in order to feed its own (protected) loads. For this purpose inverter interfaces behave as voltage source, leading with the creation of very small islands inside the MG, which will be synchronized to the LV grid when it is available. The MG main storage device (grid forming unit) is responsible for LV grid energisation. Synchronization conditions (matching phase sequence, frequency and voltage of both sides of switch) should be verified in order to prevent large transient currents and power exchanges. Loads can then be connected according to the local generation capability to supply it.

During MG restoration a cluster of voltage source inverters is operated in stand alone MG according to a MMO control strategy, reacting to system disturbances based only on information available at its terminals. In this sense, power sharing among voltage source inverters is based on frequency variations. However energy storage management is required in order to correct steady state frequency deviations during islanded operating conditions, avoiding thus storage devices be kept injecting or absorbing active power. Concerning voltage/reactive power control, as voltage has local characteristics, LV network cable impedances do not allow a precise sharing of reactive power among voltage sources inverters.

The inverter interface of MG main storage device is controlled as voltage source providing thus system voltage and frequency references. Then the control mode of

inverters of DG units with black start capability may be changed from voltage source control to power control and therefore the MG control strategy is changed from MMO to SMO. Afterwards the MG can be synchronized with the upstream MV network when it is available. It should be noted that the MG black start should be a fully automated process.

Concerning MV islands, DG with black start capability such as diesel engines and Combined Heat and Power (CHP) units commonly connected to MV grids, will start up. Then service restoration in these distribution systems can be split into main stages:

1. MV network energisation and synchronization of small islands. Some DG units with black start capability can be selected for energizing the skeleton paths of the MV network and DG units supplying their protected loads can be synchronized. Then, some load should be restored in order to balance generation and to stabilize voltage. In this stage the main problems to deal with concern mainly voltage profile and switching operations as a consequence of energizing unloaded paths and a large number of unloaded transformers.
2. Load supply and integration of generation. Load is restored according to generation requirements and MGs can be synchronized. Other DG units can also be connected to the MV network. Then, the main problems to deal with concern mainly active and reactive power balance, overloads and prime movers response to sudden load changes.

When the upstream power system becomes available MV islands can be synchronized. The synchronization conditions should be verified.

Similar black start strategies for distribution systems should be included on the restoration plans usually defined for conventional power systems restoration.

5.4 Research needs:

The islanding issue is the main concern regarding the participation of DG to the network restoration procedure. In this context, the main research needs are related with the operation of distribution systems challenges in order to exploit DG to assist system restoration.

Islanding occurs when portions of distribution system can be supplied from DG sources only, with some distinction:

- Medium Voltage (MV) islands, which can be supplied from suitable DG sources able to guarantee acceptable voltage support and frequency as well as quality of supply. These DG sources, some of them interfaced with the MV network through power electronic converters, play a key role in assisting the service restoration process on the MV islands.

- MicroGrids, seen as a particular type of MV islands, formed at the Low Voltage (LV) level, which can be operated without MV supply system. From the distribution system point of view, the whole MicroGrid (MG) behaves as a controllable cell designed to satisfy local reliability requirements and also local technical characteristics concerning voltage and frequency control as well as quality of supply. Power electronic interfaces will be exploited for these purposes and for assisting MG service restoration in the case of the absence of synchronous machines.

After a general system blackout, the service restoration on distribution systems will exploit simultaneously the BS capability of both MV islands and MGs. Thus, MG generation and control capabilities will provide fast service restoration at LV networks allowing the MGs operation in islanded mode. This first step will be afterwards followed by MGs synchronization with the MV grid when it is available, strengthening thus the MV island. Synchronization of these whole MV islands follows when the upstream HV system is available.

To enable this bottom-up restoration procedure some research is needed concerning distribution systems and power electronic converters, which interface DG units to the grid. The main requirements to be met are presented as follows:

Requirements for distribution systems:

1. Automated substations, remote controlled circuit breaker
2. Demand side management (DSM)/ Smart metering/ Controllable loads
3. Bidirectional communication
4. Adapted earthing specifications
5. Ability for simultaneous operation of several islands including MG
6. Location of synchronization devices
7. Ability to check locally the synchronisation conditions
8. Special protection schemes and coordination of protection relays

Requirements for the static converters during islanded operation:

1. Ability to be operated in grid interconnected mode and in stand alone mode
2. Ability to behave as voltage source inverters providing voltage and frequency control
3. Ability to provide voltage and frequency references for the entire MG if there are no synchronous machines
4. Ability for supplying reactive power
5. Operation of multiple voltage source inverters in parallel even if they are connected in different points along the MG
6. Sufficient contribution to the short circuit current in order to ensure the functionalities of protection systems of MV islands and MG
7. Maximum size of the fuse(s) should be adapted to the inverter's available overcurrent capability

8. Storage devices for frequency control: Independent power supply (fly-wheels, batteries, etc) connected to the grid through inverters and/or batteries connected to the dc link of power converters
9. Bidirectional communications (between both MG and LV islands and the upstream Distribution Management System (DMS))

From this latter list the first six requirements are directly linked to the static converter, whereas the dimensioning of the protection equipment, the storage and the communication are related to the micro grid operation. The requirements “reactive power supply” and “short circuit current” also apply for the fault-ride-through capability of the static converter.

5.5 Standardisation requirements:

The first standardisation requirement concerns the MG definition itself. However, following the MG definition presented previously, the static converters standardisation needs concerning system restoration include:

1. Inverter control strategies

At the first steps of MG service restoration several static converters are operated as voltage source, following a MMO control strategy. So inverter control techniques suitable to provide system voltage and frequency control during MG islanded operation are required. In addition, these control techniques should allow load sharing among voltage source inverters interfaced DG units, even connected at different points of the LV grid.

At the end of MG service restoration the MG control strategy changes from MMO control to SMO control. So, inverters should be able to change from voltage source control to power control. The MG main storage device inverter behaves as a voltage source, emulating the behaviour of a synchronous machine, controlling thus both magnitude and frequency of the output voltage.

The SMO control strategy can be followed after MG synchronization with the upstream MV system.

2. Settings for the operation in grid interconnected mode and islanded operating mode.

5.6 Literature

[1] UCTE Operation Handbook – Policy 5: Emergency Operations (final policy E, 03.05.2006). Union for the Co-ordination of Transmission of Electricity. www.ucte.org

- [2] M.M. Adibi and L.H. Fink, "Special considerations in power system restoration", IEEE Transactions on Power Systems, vol. 7, no. 4, pp. 1419-1427, Nov. 1994.
- [3] J.J. Ancona, "A framework for power system restoration following a major power failure", IEEE Transactions on Power Systems, vol. 10, no. 3, pp. 1592-1600, Aug. 1995.
- [4] M.M. Adibi, R.J. Kafka, D.P. Milanicz, "Expert system requirements for power system restoration", IEEE Transactions on Power Systems, vol. 9, no. 3, pp 1592-1600, Aug. 1994.
- [5] M.M. Adibi and L.H. Fink, "Power system restoration planning", IEEE Transactions on Power Systems, vol. 9, no. 1, pp. 22-28, Feb. 1994.
- [6] TransmissionCode 2007 - Network and System Rules of the German Transmission System Operators. Verband der Netzbetreiber VDN e.V., August 2007. www.bdew.de
- [7] C.L. Moreira, F.O. Resende, J.A. Peças Lopes, "Using low voltage microgrids for service restoration", IEEE Transactions on Power Systems, vol. 22, no. 1, pp. 395-403, Feb 2007.
- [8] T.T.H. Pham, Y. B essanger, N. Hadjsaid, D.L.Ha, "Optimizing the re-energizing of distribution systems using the full potential of dispersed generation", Proceedings of IEEE 2006 Power Engineering Society General Meeting, June 2006.

6 APPENDIX 1: DER PROTECTION AND OPERATION – A PRELIMINARY ANALYSIS

Authors: Piero Gropelli, Omar Perego, Paolo Mora (CESI RICERCA, Milan, Italy)

6.1 Introduction

As well known, the **Distributed Generation** (DG) has a revolutionary potential on the current Power System operation, because a System that was designed on a hierarchical, uni-directional power flow (from the HV to the LV crossing the MV) must meet a new requirement: accepting power ‘from low’.

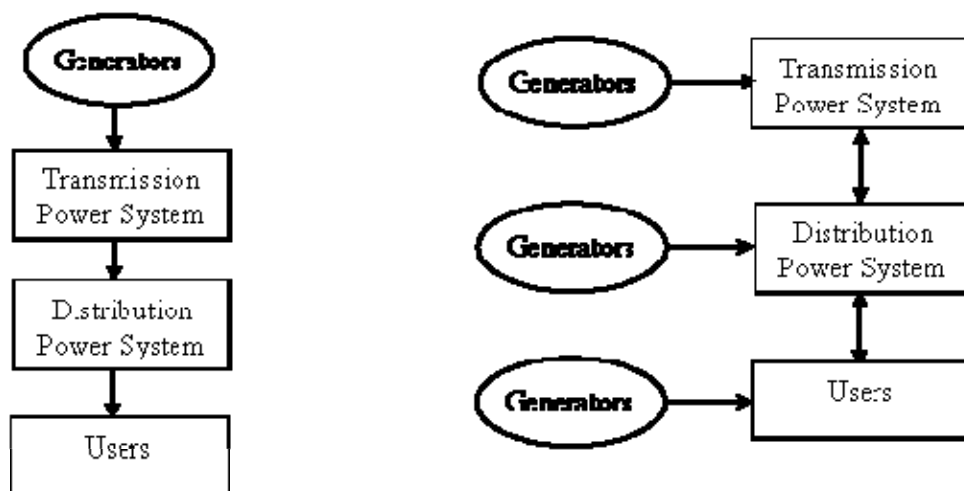

Fig. 1 : Centralized and Distributed Generation paradigms

The acronym DG can correspond to two different attributes of the term ‘Generation’, both **Distributed** or **Dispersed**, that have slightly different meaning. At the beginning (2001-2002) some experts liked better the term **On-site Generation**, to reinforce the meaning of *Generation close to the loads*. In this sense, DER (**Dis-tributed Energy Resources**) concerns more properly MV and LV grids.

The use of the DER has two main connotations:

1. gets possible local grids, the so-called **Microgrids**.
2. relies on the availability of **Power Electronics devices** that interface to the Grid the energy produced by different DER technologies with a high conversion efficiency; in a few words, **Inverter** is a key factor for the DER development.

The trinomial (DER + Microgrids + Inverter) seems not decomposable and its development will allow new energy operation/management possibilities.

The first improvement is the **autonomous operation of the Microgrid** in such a way the DER exploitation be continuous and the local loads be fed, even when the Distribution Grid is not connected to the Microgrid.

Then, possible advancing of the DER Control are currently analysed and designed in order to **integrate DER in the Power System**, that is to say, to get DER take part in Power System main quantities Control (Frequency-Voltage control).

Both goals are not easy at all to achieve, but it's evident the second goal is very ambitious: a real integration of Dispersed Resources will need a coordination with a Central Control, at least a District Control, and, for that, will need a Communication System.

Both goals still and overall rely on the Inverters capabilities that seem adequate to realize the required Control actions.

Generally speaking, one can say the DER development involves the same problems that were tackled and solved for the stable and safe operation of the existing Power System.

A so wide subject can produce different points-of-view that are based on different mental models of the observer.

The discussion about the impact of the DER on the existing Power Systems requires a clearly visible and shared reference⁷ and some specific base knowledge.

For that a schematic view of a Power System is presented in fig.2.

The figure shows a structure with :

1. two HV levels of the Transmission Power System, that is a Network Power System
2. the HV/MV substation that feeds the Distribution Power System, that is a Radial Power System and can directly feed industrial loads
3. the MV/LV substation that feeds the loads, among which the typical domestic loads
4. the main breakers at every voltage level .

⁷ The risk of misunderstanding is high without a shared reference that points out the existing structure of the Power System with its Automation, the DER connection possibilities and its consequences.

The figure summarizes the Italian Power System and the three possible Voltage levels of DER connections to the Power System. Indeed, if the DG recalls as more likely the DER development at MV and LV levels, there are also possible big concentrations of DER, whose power (>10 MW) requires the connection to the HV line and a dedicated substation. For such a plant, the local loads are actually negligible with respect to the amount of produced power.

The schemes of a MV and a LV DER are indicated with more details, with the existing breakers and the new breakers (Interface device => green box, General Device => orange block) that the Technical Standard and Distribution Utility require for the DER connection.

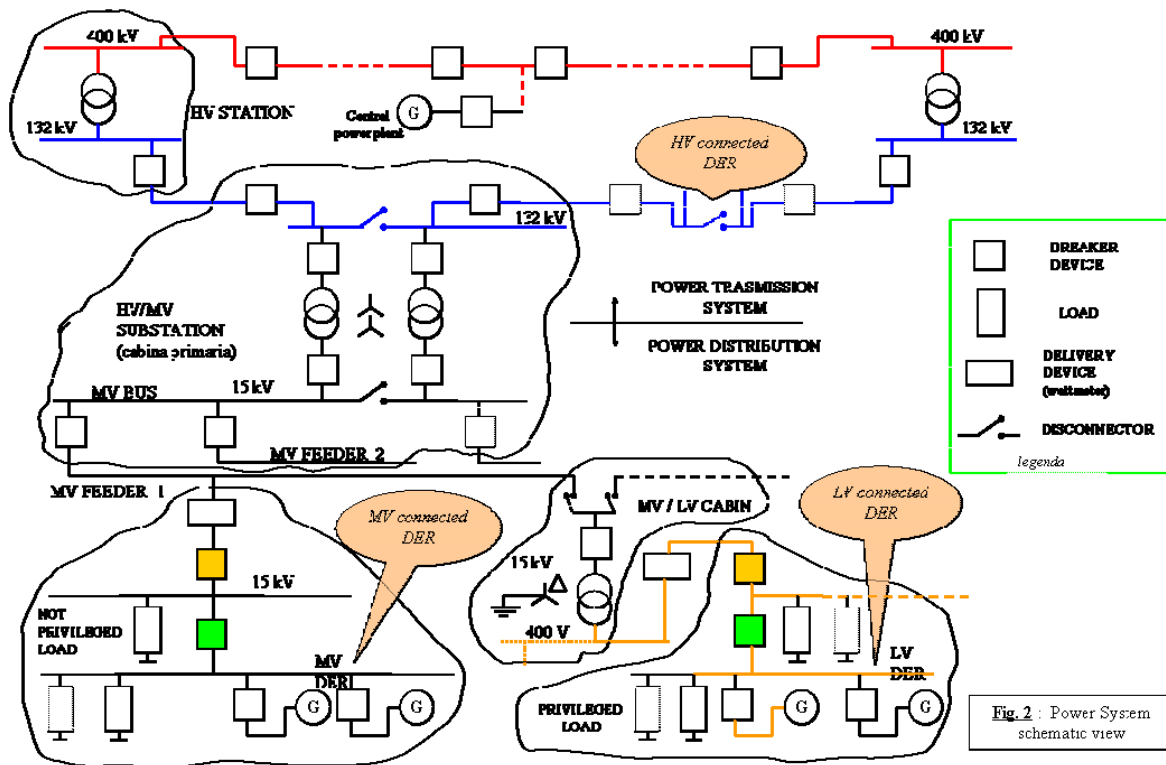

Fig. 2 : Power system schematic overview

The connection of an auto-producer to the Public Grid is ruled by a well-defined National Standards⁸, on the base of which the Distribution Utility defines the equipments and the operations of the connection.

The so-called INTERFACE Protection imposes actually some limits to the DER operation.

⁸ In Italy : NORMA ITALIANA CEI 0-16 and NORMA ITALIANA CEI 11-20.

It follows the importance of evaluating the DER automation specifications and the ‘nature’ of DER in order to achieve the autonomous operation of the auto-producer Microgrid

6.2 Critical points for the Distribution System

The connection of DER to the Distribution System changes its ‘normal working’ because, if the power produced is higher than local loads, the local grid must be represented, in term of equivalent circuit, with active elements (generators).

As both power production and local loads depend on several and different factors, the same distribution system can be active for some periods and passive for other periods. In order to define the correct operation of the Power System the duration of these periods isn’t important, what is relevant is the possibility that the local produced power be higher than local loads (passive) power, and therefore such microgrids are called active grids (the Italian “reti attive”). Assuming a widespread diffusion of the GD it would be impossible to plan the location of GD in some restricted area: all the Distribution System should/could be adequate to the new condition. To give an idea of the magnitude of the phenomenon it is worthwhile to recall some features of the main Italian utility MV Distribution System:

- total extension of the MV grid 330000 km
- number of MV lines 22500
- number of MV bus in the HV/MV substations 3800
- number of MV/LV cabin 400000

It’s worthwhile at least indicate some critical points of the MV system.

Short Circuit Currents

The connection of Synchronous and Asynchronous generators increases the short circuit current level. This increase could give short circuit currents values that are greater than values used for the dimensioning of the manoeuvre equipments (breakers and disconnectors), so the substitution of them could be necessary.

The problem is less evident when the DG is connected to the grid by Inverters. In this case the limits to the DG power can be higher, as the Inverter has short circuit currents that are noticeably lower compared to the rotating generators.

Thermal stress of the conductors

It's strictly related to the short circuit currents. For every conductor and for the short circuit duration it is set a maximum limit value of the overcurrent that the conductor can carry without damage.

It is necessary to verify the coordination between breakers - conductor – overcurrent , considering the operating times of both public grid breakers and microgrids breakers, when three-phase and bi-phase faults occur .

Control Voltage on MV and LV Grids

Control Voltage in the MV Grid is obtained by the so-called *Voltage changer under load*, that are placed on the HV winding of the HV/MV power transformer. The tap-changer modifies by steps the transformation ratio; two modalities of the control law are possible.

The first one keeps the bus MV constant, independently on the load; with this modality the GD has no effect on the wanted voltage, as the control operates without considering the entity of the load that is 'seen' by the transformer. It is clear that such control modality is not optimal in order to respect the delivery voltage limits to the users. The second modality corrects the voltage set in function of the current that passes through the transformer; this modality is better than the first one and it is usually adopted. As this control law is based on the transformer current measurement, it is influenced by the GD; in this case, indeed, the current of the transformer is no more the only current of the passive loads but it results from the balance of loads and GD. The transformer 'sees' a lower load and the voltage controller sets a lower value for the MV, when the necessary set value for the lines without GD should be higher.

The solution of this anomaly seems to be the first control modality, that, anyway, involves a lower delivery quality.

In order to maintain the limits of the voltage variations to +/- 10% at LV level, there are limits for the power and the loads that can be connected to a not-dedicated line of the Distribution System.

MV lines Automation

A lot of work has been made in order to recognize the faulty branch that can occur on a MV feeder.

The task is to disconnect the faulty branch, allowing the feeding to the users that are upstream the fault.

The developed automation bases on specific protection directional devices⁹ that are placed on the MV/LV cabins, and implements two different procedures for the two conditions *insulated neutral* and *neutral to ground by Petersen coil*. The recogni-

⁹ The Italian RGDAT, fault directional detector.

tion of the faulty branch has been experimented with good results, but the GD can upsets the logic of the automation.

Technical Standards

The current technical standards does not allow the GD to feed parts of the public grid, at any level of voltage. That is due to the real capacity of the ‘little’ generators, to the quality of the voltage delivery and to safety reasons. The GD will have to improve its features, for example every generator will have to be implemented with frequency and voltage controls.

6.3 GD impact on existing protection system

The impact of the GD on the existing protection systems is perhaps the first aspect that has been analysed. In the following, the results of a previous work is summarised.

The MV Protection concerns the following components with the specified functions:

Power Transformer HV/MV

HV side	Max current
MV side	Max current

<i>MV bus</i>	Max zero-sequence voltage
	Max voltage

<i>MV lines</i>	Max current
	Ground directional

<i>Auxiliary transformer</i>	Max current
	Ground directional

The LV protection concerns mainly the *Power transformer MV/LV* with two functions:

MV side	Max current; usually this function is achieved by fuses
LV side	Max current

As example of analysis, the power transformer protections are considered.

The HV side max current protection operates on two thresholds.

The first threshold is set to the minimum between $3 I_n$ (current nominal value) and 40% of the short circuit current on the MV bus (the value has to be reported to the HV side) ; the first threshold has a delay, about 0.5 sec; the first threshold is provided mainly to protect against MV bus three/bi-phase short circuits and as backup of the MV feeders (lines) protection.

The second threshold is set to the 130% of the short circuit current of the MV bus (the value has to be reported to the HV side); the second threshold is instantaneous; the second threshold is provided to protect the Power transformer against three/bi-phase short circuits on HV side, both inside (primary windings) and outside (terminal elements) of the transformer.

The protection on MV side operates with a single threshold, with a delay of more than 1 sec. The threshold is set to a value that is slightly higher than the overload not-permanent current. The overload not-permanent current must be tolerated by the transformer and it is usually the 140% of the nominal current. The task of this threshold is to protect the machinery when one of the Substation transformer is out-of-service and therefore only one of the Substation transformers feeds both two MV bars.

With high levels of GD, a fault on the HV side is fed both from the HV System and from the MV.

The Transformer protections are not directional and it could occur an unwanted trip, if the GD located on MV and LV grid give an amount of short circuit current that is higher than the setting thresholds.

Actually the instantaneous second threshold of the HV side max current protection has a setting value that is surely higher than the GD current amount.

It has been verified that :

- with a power GD of 75% of the transformer size (that is to say an high working condition)
- assuming all the GD concentrated on a single MV line, by one rotating synchronous generator

the GD contribution to the short circuit currents on the HV side is the 25%-30% of the instantaneous threshold. On the base of a very conservative assumption, the problem of unwanted trips of the instantaneous max current would not occur even in a emergency condition, with a single transformer working and feeding two MV bus of the HV/MV substation.

If that would not be true, a fault on a HV line (that is located near to the substation) would involve an operation of the transformer protection and a relatively long out-of-service of its MV grid .

About the other two thresholds, their delays should not allow to operate, firstly, for the operation of the distance protections and , secondly, if the voltage sag is enough deep with a sufficient duration, for the operation of the Interface protection of every GD generators. By the Interface Protection operation the GD contribution to the short circuit current is excluded.

Resuming the results of an oriented analysis for every protection:

1. on the **MV bus protection** (both max zero-sequence voltage and max phase-to-phase voltage) the GD impact should not be relevant
2. on the **MV line Ground directional protection** the GD impact should not be relevant for the 1st and 2nd thresholds; the GD impact on the 3rd threshold, that concerns the double mono-phase fault (fault to ground of two different phases of two different lines) can be relevant
3. on the **MV line max current protection** the GD impact can be relevant
4. on the **Distance protection** there is not a GD impact
5. on the **LV max current protection fuse** the GD impact must be evaluated at MV level and at LV level; with a high GD connected to MV level it is necessary to evaluate if the ‘increased’ short current circuit are tolerated by the fuses; with a high GD connected to LV level , it is necessary to evaluate that the contribution of the LV GD to the short circuit on MV lines don’t involve the fuse operation; even for a transient fault on MV lines, a long out-of-service could occur for the users that are connected to the MV/LV cabin; taking in count the size of existing fuse, a GD level of 50% of the MV/LV transformer should not involve selectivity problems.

About point 3, the problem arises because the Max current line protection is not directional; for that, unwanted trips could occur on a line with high GD for faults on other lines on the same MV bus.

For example, a three-phase fault on the Feeder 2, close to the bus, can be fed by GD connected to Feeder 1 by a current that is higher of the usual setting thresholds: an unwanted trip puts out-of-service a not-faulty line.

It must be said that the problem is overall related to rotating generators, which can contribute to short circuit current in a relevant measure. With an Inverter Interface the contribution can be relevant only in case of a ‘big’ power plant. Anyway, it is necessary to analyse the single case in order to verify the compatibility between the existing Line protection setting and the amount of GD.

For this computation every data of the Electrical System, e.g. the location of GD generators, and of the protection setting must be known.

The point 4 deserves a remark. As shown in figure 2, the connection of AT System to the MV System takes place in the AT/MV substation in a standard way, with the AT line *getting-in* and *getting-out* (in Italian “entra-esci” ; obviously these term are quite conventional).

Two distance protections are located at IN and at OUT terminal; they measure voltages and currents to evaluate the impedance in the direction of the line. In this topology all the GD connected to a given MV doesn't change the first zone impedance setting (usually 80% of the line length) of the distance protections that are connected to the same Substation.

What can be influenced by the same GD are the second zone (usually 80%-120%) and the third zone of the contiguous distance protection, that is to say the setting of back-up zones.

The problem of a GD impact on the main zone of a distance protection could occur if these standard topology and protection equipment can't be adopted ; if, for any reason, a big DG concentration (> 10 MW) is connected to the AT System in a different way, it is clear the existing distance protection that are contiguous to the connection point will measure the impedance with an error depending on the GD amount.

6.4 Basics of the Inverter Control

To approach the subject of the Inverter Control it is useful at first to consider the case of a **single Inverter which feeds a microgrid, but it is not connected to the public grid**, with a batteries set as DC power source.

Such a condition implies a Voltage control as the only possible law control.

Assuming the control electronics uses the PWM modulation, the control scheme has to create a sinusoidal modulating signal on the base of a voltage error in order to have a sinusoidal voltage output, that is characterized by nominal values of frequency and amplitude.

The voltage error can be computed as the difference between

- the instantaneous values of the sinusoidal set point and the measurement
- the RMS values of the 2 quantities .
-

In any case the form and the frequency of the modulating signal are imposed and processed by a reference that is internal to the Control.

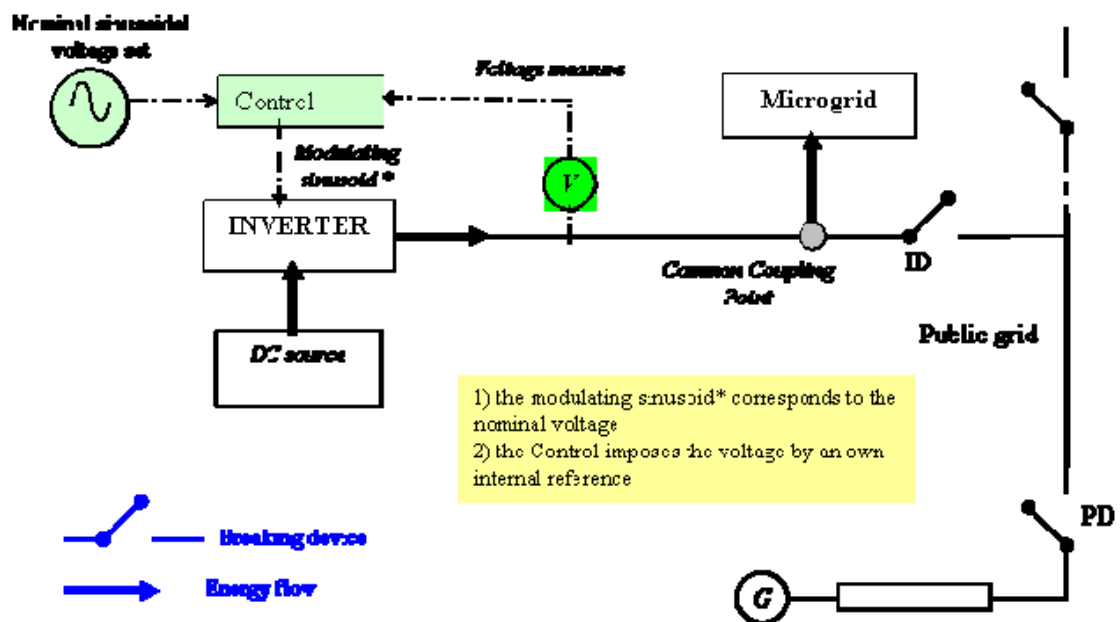

Fig. 3: Single Inverter not connected to public grid

Even if in the standard voltage control scheme it is often present an internal current loop, that does not change the control philosophy of a single, not connected Inverter.

It's worthwhile to note that:

1. The energy flow is uni-directional; an inverter has not to be necessarily a 4 quadrant device if it works in a not-connected condition.
2. The loads of the Microgrid impose the active and reactive power
3. In the more frequent case of VSI (Voltage Source Inverter) inverter, the voltage output is sinusoidal only with a minimum load that allows a minimum circulating current; without output current, that is to say without load, the voltage output is a train of negative and positive, width-modulated pulses.

Together with a correct control law, the operation of the very simple microgrid of the figure 3 would require some logics of inter-blocking/protection. For example:

- It's evident that the ID breaker (Interface device) can't be closed when the Inverter is working
- Before activating the inverter, the ID state must be verified and, if the state is *closed*, the opening of the ID must be forced, even if the public grid is not fed for the opening of PD (Line Breaker) ; up to now GD may not work in 'islanding' with parts of the public grid .

In the condition of a **single inverter that is connected to the public grid**, the voltage and the frequency are imposed by the public grid : the main task of the control is to synchronize the Inverter with the Public Grid.

The big power generator, that is the equivalent of the public grid, allows a bi-directional power exchange between (Microgrid+Inverter) and the public grid. Three states are possible for what concerns the power balance :

1. The Inverter generates a power that is higher than local loads power: the amount of exceeding power is delivered to the public grid
2. The Inverter generates a power that is lower than local loads power: the difference necessary to feed local loads is delivered by the public grid
3. The inverter has no available energy source: all the power that is required by the microgrid is delivered by the public grid ; if the inverter is a 4-quadrant device it can work as re-charger of a storage system.

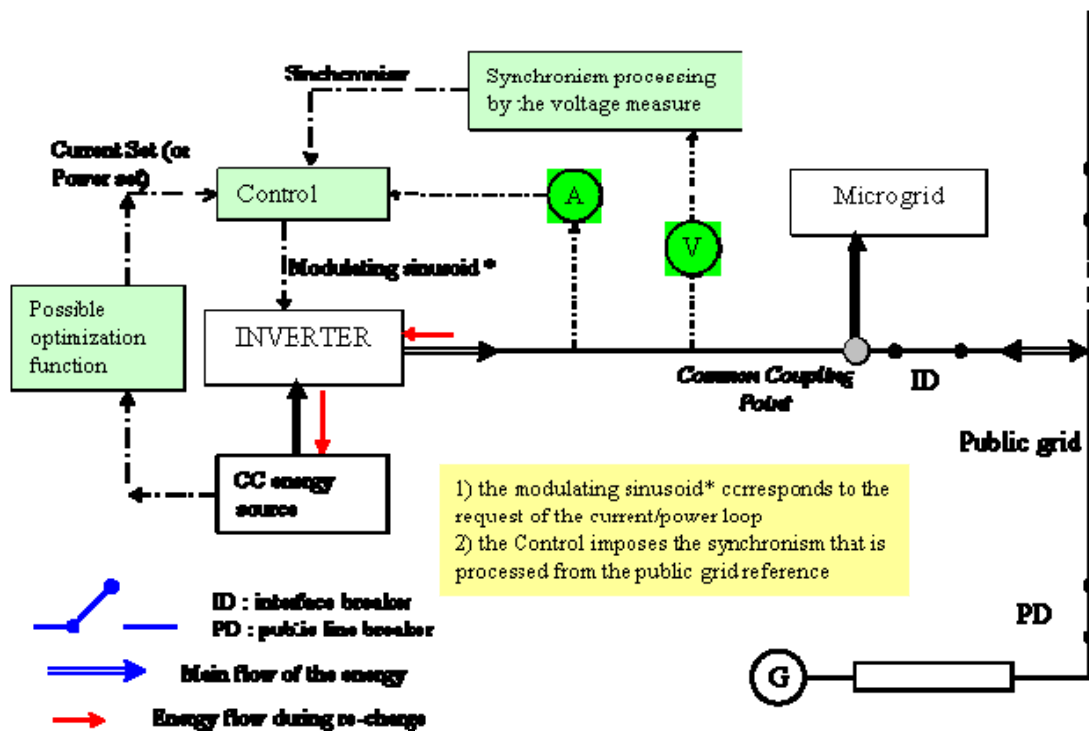

Fig. 4 : Single Inverter connected to public grid

In the figure 4 it is pointed out that the energy exchange has not a privileged sense, as it depends on the loads variable conditions and on the local energy production.

The condition of an Inverter connected to the public grid is the optimal condition to exploit the GD energy, specially for the renewable resources. The public grid connection grants in any case the feeding of the local loads, independently on the availability of the Inverter delivered energy, and allows the full use of the GD energy when it is higher than the microgrid request.

Indicating with the acronym **CON** the *Connection to the public grid condition* and with the acronym **NOC** the *Microgrid disconnected condition*, the two described control laws are dual and allow an useful comparison.

The table resumes the working duality of a single Inverter in the two conditions.

Single inverter: comparative table of NOC and CON working

Features of the control scheme	Single Inverte NOt Connected	Single Inverter CONnected
<i>Waveform reference</i>	Autonomous, by an internal signal generator, with nominal values of voltage and frequency	Re-built on the base of instantaneous frequency, amplitude and phase of the public grid voltage
<i>Synchronism</i>	Not necessary	Processed from the public grid voltage measure
<i>Control law</i>	Voltage ; the current is a consequence of the loads and the imposed voltage	Current ; the voltage is imposed by the public grid
<i>Necessary measures</i>	Voltage	Current and voltage
<i>Typical use</i>	Feeding of microgrids not reachable by the Public grid.	Power interface between GD and Distribution system.
Advantage	Can feed a Microgrid	Can exploit with an optimisation criterion the GD energy.
Handicap	Can't do any optimisation	Can't feed a microgrid when the public grid disconnects.

The current control modality works also with many inverters in the CON condition.

On the contrary , the condition of many inverters in a NOC condition must solve the critical point that is related to the synchronisation of different generators.

Without the external synchronism that is imposed by the public grid in the CON condition, 3 possibilities can be evaluated :

- One single sinusoidal signal is transmitted to the different inverters feeding the Microgrids
- Only one Inverter, with Master function, controls the voltage, while other Inverters take the synchronism from the voltage microgrid
- Every inverter takes part in the control of the voltage/frequency of the microgrid, with a DROOP control modality, that is a Proportional control (without the Integral block), on the base of local set-points.

The last modality assumes the participation of different machines to the frequency and voltage control can support a stable steady-state, accepting steady-state errors with respect to nominal values of frequency and voltage.

The first possibility requires a centralised control system; even not considering the cost of this solution, the problem is the communication time because the time steps of the Inverter control are very small.

The second possibility is useful because it gets evident at least one generator must take in charge of compensating the power/load balance.

Indeed, without the public grid that compensates the balance of local power and local loads, the operation of more inverters on the same insulated micro-grids requires an energy fly-wheel.

As well-known, most of the inverter that interface GD to the Distribution System work on the base of the maximum exploitation of the produced energy. The PV inverter actuates a Maximum Power Point Tracking (MPPT) that can be considered the most selfish control modality; in general, the renewable resources don't offer storage or flywheel possibility; wind and sun can give energy but can't store it.

There is then a key question: is it possible a control scheme, which is integrated by a suited automation logic, that keeps working the GD in both CON and NOC conditions, allowing the continuous feeding of the local loads and the full exploitation of the available energy ?

The experience in the automation field, specifically in the control field, allows to answer that the shift from a control scheme to another one can rely on usual techniques (set following and balancing, ..) that give reliable results, but the solution is not only a matter of the control scheme: the microgrid needs a storage system to operate in the NOC condition.

The Power System is stable thanks to a continuous action of the primary voltage and frequency controls of the synchronous generators; the dynamic equilibrium of the power system is possible because the power can be decreased-increased in real-time with the loads variations.

On the contrary, DG at the moment is not a fully controllable energy.

Even not considering the costs and the many problems due to the structure of the existing Power System, the complete integration of the DG has a specific difficulty.

It must be said that the Power Electronics technology has given extraordinary results, and if a lot of work must still be made, the next future will see further advances in Inverter Control and consequently further advances in GD use.

Only few years ago, it was not possible to interface DER to the Distribution system with the high efficiency of today.

**CHAPTER 3: CONTROL AND COMMUNICATION
FOR
OPERATION OF INVERTERS IN FUTURE POWER SYSTEMS**

Nikos Hatziargyriou¹, Takis Romanos², Erietta Zountouridou³, Aris Dimeas⁴:

*National Technical University of Athens (NTUA) 9 Heroon Polytechniou Str.,
15773 Zografou, Greece
Phone: 30(210)7723661*

*Email: ¹nh@power.ece.ntua.gr ²romanos@power.ece.ntua.gr
³eriettaz@power.ece.ntua.gr ⁴adimeas@power.ece.ntua.gr*

Khalil Ali Tarhini

*Abu Dhabi Distribution Co., P.O. Box: 219, Abu Dhabi, United Arab Emirates
Phone +971(2)6949100,
Email: Ktarhini@addc.ae*

Matthias Stifter

*arsenal research, Giefingasse 2, 1210 Vienna, Austria,
Phone: +43(50550)6351,*

Email: Matthias.Stifter@arsenal.ac.at

Jens Merten, Xavier Le Pivert

*CEA/INES, 50, avenue du Lac Lemman, 73377 Le Bourget du lac Cedex, France
Phone +33/4.79.44.45.60*

Email : Jens.Merten @ cea.fr

David Nestle, Jan Ringelstein

Fraunhofer IWES, Königstor 59, D-34119 Kassel

Statis Tselepis

CRES, 19th km Marathonos Ave., Pikermi, 19009 Athens, Greece

ABSTRACT

This chapter aims to present the development of Control and Communication Concepts for operation of inverters for future power systems. For the purpose of standardization communication needs, inverters are assumed as black boxes and the communication is realised by their inputs and outputs. The Communication requirements for controlling the future power systems are analysed. Communication technologies and topologies are described based on ISO OSI (Open System Interconnection) seven-layer model [IEEE 2007] open standard, achieving Interoperability and Interworkability. The Performance, Reliability, Security, Privacy, Scalability, Extensibility and Hierarchy Concepts are also analysed in this chapter. Existing standards are investigated for covering the developed Control and Communication Concepts. Furthermore, the concept of Energy Management System is taken into account and concerns the design parameters for the complete system, the operation modes, the management strategies and the congestion management. Conclusions are derived by reporting the concepts of operation of the inverters which are not standardised yet and must be covered by the expansion of existing electrical standards or by the creation of new standards.

3.1	Introduction	80
3.1.1	Time scales for Network Control and Energy Management	81
3.1.2	Energy Management.....	84
3.1.2.1	Definition of energy management systems.....	84
3.1.2.2	Objectives for energy management	85
3.1.2.3	Forecasts/ Prediction of production and consumption,.....	86
3.1.2.4	Local Energy Management.....	86
3.1.2.5	Incentives/Motivation for participation to load management.....	87
3.1.2.6	Devices for local energy management.....	88
3.1.2.7	User interface.....	88
3.1.2.8	Smart Metering.....	88
3.2	ICT.....	90
3.2.1	Communication requirements for Controlling of Future Power Systems	91
3.2.1.1	Data exchange between local and global EMS.....	91
3.2.1.2	Data exchange from local to global EMS.....	92
3.2.1.3	Data exchange from global EMS (DSO) to local EMS.....	93
3.2.1.4	Data exchange from global EMS (Broker) to local EMS.....	93
3.2.1.5	Data exchange between local EMS's	94
3.2.1.6	Data exchange between global EMS (DSO) and global EMS (Broker)	94
3.2.2	Control with price signals or state of system signals?	94
3.2.3	General Communication Protocol Requirements	96
3.2.4	Communication technologies	99
3.2.5	Communication topology	100
3.2.6	Open standard / Interoperability / Interworkability	101
3.2.7	Performance and Reliability	102
3.2.8	Security and Privacy	102
3.2.9	Scalability and Extensibility	103
3.2.10	Hierarchy	103

3.2.11	Standardization activity for DGs	105
3.2.11.1	IEC 61850/IEC 618970	105
3.3	Conclusions	108
3.4	List of Standards.....	110
3.5	Literature	111

3.1 Introduction

Modern society critically depends on a secure of high-quality electrical energy. Increasing concerns for primary energy availability, the aging infrastructure of current transmission and distribution electrical networks, the need to connect non-traditional generation such as intermittent renewables, and active open wholesale markets are increasingly challenging security, reliability, and quality. Very significant amounts of investment will be required to develop and renew the electrical infrastructure, and the most efficient way to meet social demands will likely be by incorporating innovative solutions, technologies, and grid architectures. According to an International Energy Agency estimate, global investments required in the energy sector over the period 2003-2030 are about US\$16 trillion.

Future electricity grids have to adapt to changes in technology while matching societal values for the environment and commerce. Thus, system security, safety, environment, power quality, cost of supply, and energy efficiency are examined in new ways in response to changing requirements in a liberalized market environment. Technologies should also demonstrate reliability, sustainability, and cost-effectiveness. At the distribution level, the new requirements call for development of:

- Distribution grids accessible to distributed generation (DG) and renewable energy sources (RESs), either self-dispatched or dispatched by local distribution system operators
- Distribution grids enabling local energy demand management interacting with end users through smart metering systems
- Distribution grids that benefit transmission dynamic control techniques and overall level of power security, quality, reliability, and availability.

In summary, distribution grids are being transformed from passive to active networks in the sense that decision making and control is distributed and the power flows bidirectionally. This type of network eases the participation of DG, RESs, demand response (DR), and energy storage and creates opportunities for novel types of equipment and services, all of which would need to respect common protocols and standards. The function of the active distribution network is to efficiently link power sources with customer demands, allowing both to decide how best to operate in real time. Power flow assessment, voltage control, and protection require cost-competitive technologies and new communication systems with information and communication technologies (ICTs) playing a key role.

The realization of active distribution network technologies will allow radically new system concepts to be implemented. Perhaps the most promising novel device is the inverter. Microgrids comprise low voltage (LV) distribution systems with distributed energy resources (DERs) such as microturbines, fuel cells, photovoltaic

(PV) arrays, etc., together with storage devices (i.e., flywheels, energy capacitors, and batteries) and controllable loads, offering considerable control capabilities over the network operation. These systems are interconnected to the medium voltage (MV) distribution network, but they can be also operated isolated from the main grid in case of faults in the upstream network. From the customer point of view, inverters provide electricity needs and in addition enhance local reliability, reduce emissions, improve power quality by supporting voltage and reduce dips, and potentially lower costs of energy supply. From the grid's point of view, inverters can be regarded as a controlled entity within the power system that can be operated as a single aggregated load or generator and, given attractive remuneration, as a source of power quality or ancillary services supporting the network. Thus, the behaviour of DERs and DR is coordinated, and the benefits to customers and grids are maximized.

From the utility point of view, application of DERs can be potentially reduce the demand for distribution and transmission facilities. Clearly, DG located close to loads will reduce flows in transmission and distribution circuits with two important effects: loss reduction and ability to potentially substitute for network assets. Furthermore, the presence of generation close to demand could increase the service quality seen by end customers. Inverters can provide network support in times of stress by relieving congestion and aiding restoration after faults. The standardization communication of operation of inverters in future power systems will play a significant role in achieving all the above-mentioned benefits.

3.1.1 Time scales for Network Control and Energy Management

In any electric system, the active power has to be generated at the same time as it is consumed. Power generated must be maintained in constant equilibrium with power consumed / demanded,. Disturbances in this balance, causing a deviation of the system frequency from its set-point values, are subject to a control system of classic grids which has several levels which are indicated in the orange area of the Figure:

- First, the disturbances will be offset initially by the kinetic energy of the rotating generating sets and motors connected. This is the “**passive**” **primary control** which is happening almost instantaneously .
- The next step is an **active primary control**, which will cause the primary controllers of all generators subject to primary control to respond within a few seconds. These controllers alter the power delivered by the generators until a balance between power output and consumption is re-established.
- As soon as the balance is re-established, the system frequency stabilises and remains at a quasi-steady-state value, but differs from the frequency set-point. Consequently, power cross-border exchanges in the interconnected system will differ from values agreed between companies. **Seco-**

dary control will take over the remaining frequency and power deviation after 15 to 30 seconds. The function of secondary control is to restore power cross-border exchanges to their (programmed) set-point values and to restore the system frequency to its set-point value at the same time. In practise, the demand varies continuously, even without having forecast errors, so that secondary control on a real-time basis is continuously required.

- The last step is **tertiary control**. The aim of this control, co-ordinated by the national dispatching centre, is to mobilise the tertiary reserve throughout the day, as much as needed. The rapidly mobilised power reserve is set up with generation sets which are not at maximum power or which can start up quickly (hydro generation sets, combustion turbines).

It is the secondary and tertiary controls which deal with the energy flows of the DER systems. It is also called **global Energy Management system** in this chapter.

A DER system (which consists at least of two of the following components: generator, consumer, storage, grid connection) and has the following control levels:

- **Power electronics** is controlled by pulse width modulation in order to achieve the desired waveform and to control the energy flows from and into the grid. This process is very fast – less than $100\mu\text{s}$ – and happens internally on inverter level according to the control signals coming from the local energy management system and is not treated in this chapter.
- **Shedding of loads**, or demand side management, is possible if local consumption is too high. This process is also fast – less than 1s – and is realized according to the control signals coming from the local energy management system.
- The **Energy management system** is controlling the energy flows between the four components of the DER system and the resulting energy flow between the DER system and the grid. This process is rather low between minutes and hours.

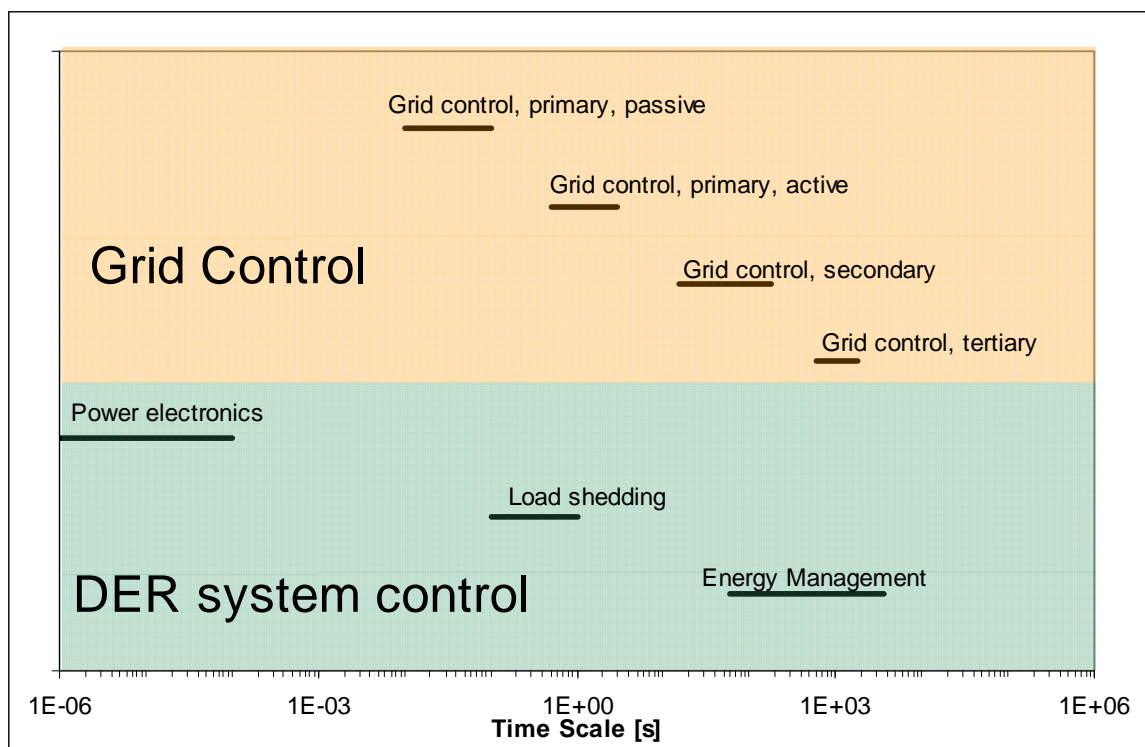

3.1.2 Energy Management

3.1.2.1 Definition of energy management systems

The term energy management is used for various different tasks. Usually it means shifting energy consumption or generation in order to optimise for costs, which may be composed of electricity acquired from a market/supplier, grid fees, losses and other factors. Today the most common form of energy management is local peak shaving, which is economically favourable for customers, who pay part of their grid fees based on the maximum power flow from the grid within a certain billing period.

Energy management is also sometimes used for holistic strategies aiming at optimisation of the whole energy demand and generation. In this case also saving energy by investing into more efficient equipment or changing user behaviour is part of energy management.

In the following section, however, energy management is only referred to as an optimisation process aiming at shifting energy flows or at maximum allowing for short term reduction in energy consumption because of a special technical and/or economical situation at a certain time.

Energy management is needed for each local DER system level, but also on a more general level, when many DER systems should act as a virtual power plant.

The local DER system as shown in the Figure, consists at least of two of the following components

- a local energy producer,
- a local energy storage,
- a local consumption
- a connection to the grid

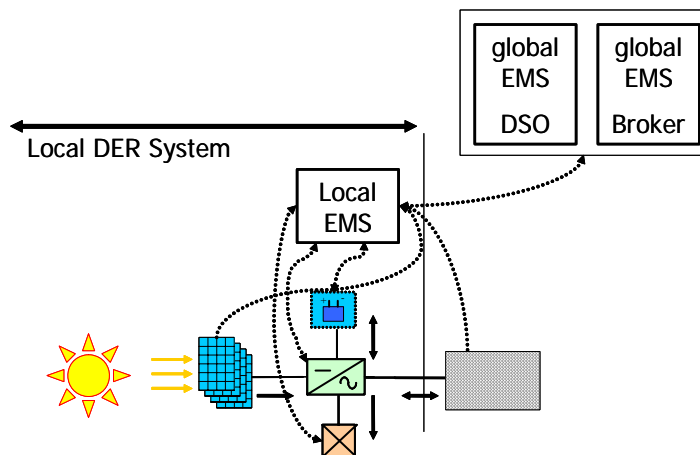

The energy management is realised by a local energy management system. Definition of the local Energy Management System:

The local Energy Management System is a system optimising the energy flows between the components of the local DER system and the electricity grid

The local energy management system receives information from a global energy management system and/or an electricity broker. This is the only way how many DER systems can act as a virtual power plant. Definition of the local Energy Management System:

The global Energy Management System optimising the energy flows between a multitude of DER systems and the electricity grid.

3.1.2.2 Objectives for energy management

The criteria for the optimisation depend on the contractual framework and the interests of the operator of the local DER system. Examples for optimisation criteria for the local EMS are

- lowest cost for electricity drawn from the grid
- high cost for electricity injected into the grid
- maximum lifetime of system components (batteries)
- maximum availability of local electricity service (in case of blackouts)
- Minimisation of electricity drawn from the grid (for “idealistic reasons or because of high price)
- Maximisation of locally produced energy,
- minimisation of CO₂-emissions

Similarly, the criteria for the optimisation of a set of DER systems depend on the contractual framework and the interests of the operator of these systems. Examples for optimisation criteria for the global EMS are:

- Maximisation of profit
- Avoidance of grid overloads, congestion, and instabilities
- Delivery of balancing power
- Minimisation of CO₂-emissions

3.1.2.3 Forecasts/ Prediction of production and consumption,

Prediction systems are decisive for most energy management systems. Not only customer behaviour prediction as mentioned before but also weather prediction in many cases (solar energy, wind energy, consumption for light and heating).

The update rate of the management signals or the frequency of interference by the energy management systems are also important parameters.

- Some management strategies define fixed tariffs for each time of the day without the possibility of an adaption for one year.
- Other management systems perform online control requiring broadband communication access.

3.1.2.4 Local Energy Management

When reviewing research literature on state-of-the-art technical solutions for local EMS (BEMI, FENIX-Box, EWE-Box, ...), it can be noted that research results indicate that those solutions must comprise several elements:

- A means for automated device switching and/or supervision (i.e. relais or similar)
- A means for communication with a wide area network
- A means for recording metering data which can typically be transmitted over the wide area network
- A computational core
- A user interface (i.e. display, webserver, switches, ...)
- Possibly a means for grid supervision or measurement of physical data at the point of common coupling

Strangely, although several devices have been demonstrated so far that include at most of the aforementioned elements, there has been surprisingly little effort for standardisation of local energy management hardware, especially when compared with standardisation of local communication. However, standardisation effort is needed in order to make devices available which allow for local energy management and are cheap enough to allow a mass market rollout, while at the same time allowing competition between different manufacturers. This must be especially considered while looking at ongoing development in the smart metering business, since otherwise it can be doubted if a mass-rollout of local energy management devices can be expected in the near future. This could again be a main hinder for the introduction of global energy management systems in the first place.

3.1.2.5 Incentives/Motivation for participation to load management

The most important attribute of an energy management system is the kind of incentive towards the legal entities involved. Usually this can either be rules set by the regulatory framework, rules set by a contractual framework or flexible incentives (price). In case of rules set by a regulatory or contractual framework the management usually is performed by direct control of the generators and loads from a central control station. The EMS would thus be centrally organized. The owner/user of the devices has very limited rights influence the management actions. For this reason this kind of management is usually limited to relatively rare management actions to avoid grid overload or for shaving of a yearly peak power. The advantage from the point of grid management is the reliability of the measures taken, major problems are the inflexibility for the customers and the effort for central control and communication required for this kind of management.

In case of flexible incentives like a time-variable energy tariff or a grid fee depending on the maximum power obtained during a certain billing period (decentrally organized EMS) the exact behaviour of the customers and their devices cannot be known beforehand. These management efforts are only effective when looking at a large number of customers, whose reaction to such pricing incentives can be predicted robustly on a statistical basis. Therefore, a system of variable tariffs can be a reliable tool for grid operators and energy suppliers while being very flexible for individual customers (Concept of “decentralized decision based on central and local information”) [Bendel 2007]. In case the number of customers participating is too small to ensure the statistical averaging and prediction, it must be supported by other control mechanisms, though.

For effective participation in such a flexible energy management system each customer needs his own energy management tool, which optimizes his or her energy demand according to the incentives given. E.g. in case of a grid fee payable for the yearly maximum power drawn from the grid this would be a peak power shaving management as it is frequently performed by commercial customers today. In case of a timevariant energy tariff a local management is required considering the preferences of the inhabitants of the building, the parameters of the devices included in the management and the information received from the central station. In order to avoid avalanching effects in the grid when a large number of devices would switch at the same time when the price changes, not all customers should receive exactly the same tariff, but tariffs should be varied so that the aggregated reaction of all customers supplied by the system follows a given power profile within the usual forecast uncertainty.

3.1.2.6 Devices for local energy management

A wide variety of energy management strategies are available and suit different customers and different types of generators/loads. Shifting energy generation or consumption requires storage (not necessarily storage of electrical energy) or an application that can be shifted. In the area of private households such devices are freezers and fridges, electrical heating and warm water generation, air conditioning and ventilation, washing machines, dryers and dish washers as well as cogeneration devices. In the future this list may include uninterruptible power supplies (UPS), electrically driven vehicles and photovoltaic inverters equipped with additional battery storage. Three basic types of devices must be differentiated regarding energy management:

- devices with thermal or battery storage, which stateofcharge (SOC) must be maintained within a certain range
- devices which carry out a fixed program with shiftable starting time (e.g. washing machine)
- devices which can reduce their power at high electricity prices (e.g. a dimmable lighting)

Algorithms for each device type must be designed in a way that avoids avalanching effects by switching all devices at the same time. This can be achieved by small, random shifts of switching times [Taylor 2002].

3.1.2.7 User interface

For every energy management it is also important to have a user interface that gives the customer information on the current status of the system and the manangement performed. For flexible management strategies the user should also be able to interact and change the schedules calculated by the local optimization system. In all cases building automation systems are decisive so that generators and loads can be switched automatically.

3.1.2.8 Smart Metering

Energy management systems can work without realtime feedback from the customers/appliances, but it may be part of an energy management strategy to get this kind of feedback. For the system supervision and billing some kind of feedback (possibly much later than the actual time of management) is usually required, however. For all incentivebased strategies a suitable smart metering is required that gives the information required for billing according to the price incentive.

3.2 ICT

The Information and Communication Technology (ICT) is a critical part of the future power networks. Beyond any doubt the control and operation of the future power grids including Microgrids will be supported by sophisticated Information system as well advanced communication network. Currently several technologies are implemented or tested within power system and the usage will become more extensive.

Information and communication technology (ICT) is a key element for control and energy management systems. The operation of such systems would be virtually impossible without ICT. Typically, the needed ICT comprises the following elements:

- 1) Computational systems for local EMS which supervise and control locally connected devices. Such systems can also comprise a grid supervision or carry out optimization of device operation according to optimization goals depicted in 2.1.3.
- 2) Computational systems for global EMS which optimize the overall system according to optimisation goals depicted in 2.1.3.
- 3) Communication technologies for interconnection of local EMS and local devices that are controlled by the local EMS. If local devices are situated in a building, these technologies are quite similar to building automation systems. Thus the same communication can be used for EMS and building automation in some cases.
- 4) Communication technologies for interconnection of local and global EMS as well as – in some cases – interconnection of multiple local EMS.

Examples for those elements:

- 1) Grid Inverter with EMS functionality, Bidirectional Energy Management Interface [Bendel 2007], ..
- 2) Central station of a virtual power plant
- 3) Any local area network or field bus, i.e. LAN, WLAN, MODBUS, ...
- 4) Wide-Area Network, i.e. DSL, ISDN, GPRS, ...

It should be noted that many energy management systems in “real world” are comprising devices which are distributed over large regions. Therefore, the needed ICT system for 4) would historically be called a “telecontrol system”. If one were to implement such systems 10 years ago, specialized technologies would have been state of the art. But since the Internet has become broadly used, web-based technologies are more and more replacing those specialised systems.

3.2.1 Communication requirements for Controlling of Future Power Systems

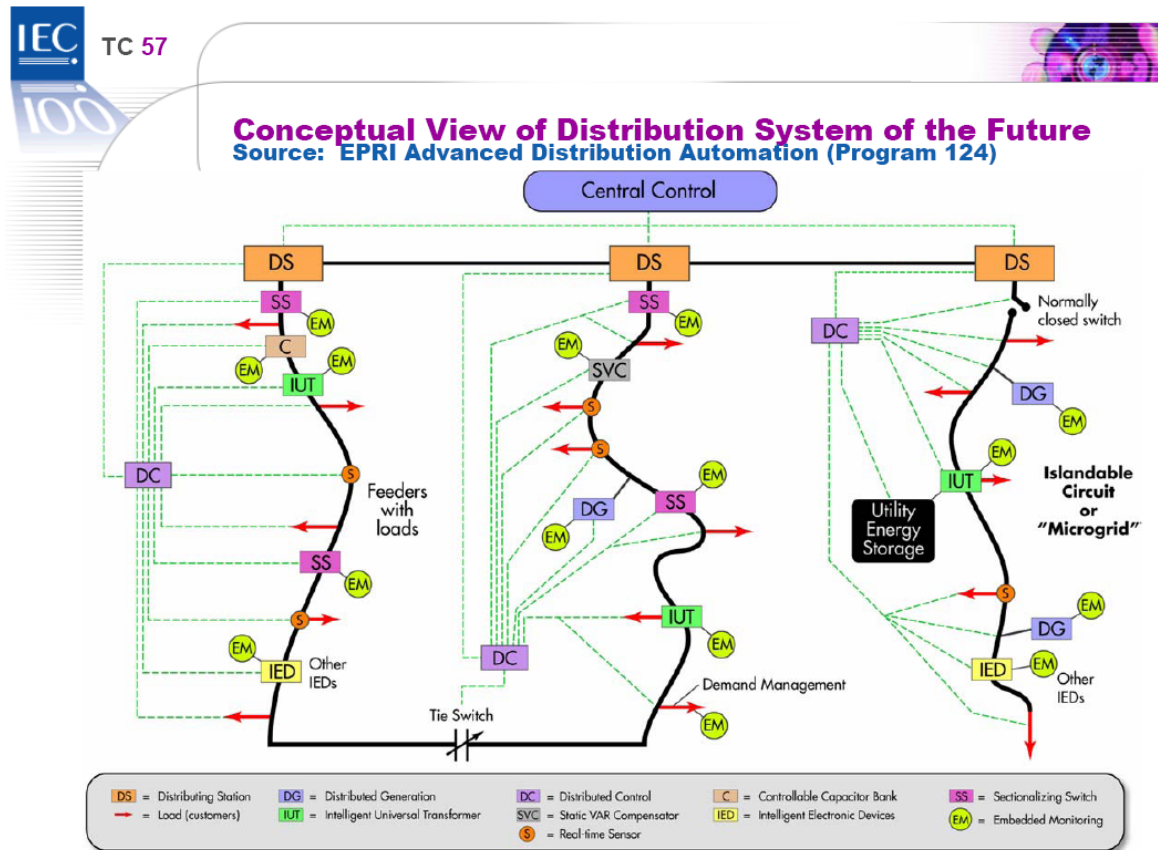

Figure 8: Communication technology requirements for the Distribution System of the future [Good 2007]

3.2.1.1 Data exchange between local and global EMS

The exact kind of data to be communicated within the EMS system can not be defined without considering the organization of the EMS. For the scope of this chapter, the following definitions are made:

- An EMS is called **centrally organized** if it consists of a global EMS which comprises a central station that knows or can get to know the technical specifications and the operational states of all devices controlled by local EMS's and calculates operational schedules for those devices which then have to be executed by the local EMS's.
- An EMS is called **distributed organized** if:
 - it consists of a global EMS which has no knowledge over the technical specifications or the current operational states of all devices controlled by local EMS's or

- if there is no global EMS at all, but local EMS's optimize device operation using algorithms which comprise information exchange between local EMS's (implemented in so-called agent-based systems).

NOTE: if the global EMS transmits minimum/maximum setpoints to local EMS's which, for example, restrict the infeed power, this is still called "decentrally organized" if the global EMS has no means of getting to know the current operational state of the local devices.

- An EMS is called **locally organized** if there is no global EMS *and* local EMS's control device operation solely by information gathered locally. This would be, for example, a local EMS which controls a generator's infeed by observing the grid frequency at the point of common coupling.

An example for the first type is the "classical" virtual power plant. Examples for the second type are the Bidirectional Energy Management Interface system, comprising a Pool-BEMI as global EMS. Such a global EMS can thus only give incentives, but can not carry out a full control of all devices, since the decision on device operation is made by the local EMS's. It is important to note that a combination of those EMS types is also possible. For example, local EMS's could control infeeds by observing grid frequency while still receiving incentives from a global EMS. Such an EMS would still be called "decentrally organized".

It's easy to see that in a purely locally organized EMS, there is no need for data communication, although in literature, the measurement of grid frequency or voltage is also identified as some kind of information transfer. Within this work, "data transfer" only applies to the first two types of EMS.

3.2.1.2 Data exchange from local to global EMS

In case of a centrally controlled EMS, almost any kind of data considering type and current operational status of local devices or local EMS is in question for transmission to the global EMS. This comprises:

- List of local devices in control by the local EMS, namely their types, manufacturer information, operation hours, maintainance status, location on the customer's premises, type of grid connection, ...
- Technical abilities of devices, i.e. possible compensation of harmonics, ..
- Available energy
 - in local storage
 - energy forecast
- Available power

- Current power infeed or consumption (real, reactive)
- Maximum power infeed or consumption (real, reactive)

In case the EMS is controlled decentrally, data transmission to the global EMS is typically very limited:

- Current overall infeed or consumption
- Current status of local EMS, i.e. possibility to increase current active infeed power on short-term
- Information about possible incentives or incentive offers to global EMS (often the case in agent-based EMS)
- Profile metering data

As for standardization, there recently has been much activity within the IEC which led to the draft standard IEC 61850-7-420 [Franke 2007]. This standard also gives a list of communication requirements between local and global EMS.

3.2.1.3 Data exchange from global EMS (DSO) to local EMS

Information exchanged at this point would be connected with technical or operational states of the grid, for example:

- Setpoints
 - to assure safe operation of the grid, defined “by law”
 - to limit generation
 - to limit consumption

3.2.1.4 Data exchange from global EMS (Broker) to local EMS

In case of a centrally controlled EMS, information to be exchanged at this point mainly consists of device operation schedules. This can apply to:

- Day-Ahead Schedules for active or reactive power consumption or infeed
- Currently requested power
 - For generation
 - For consumption limitation

In a decentrally controlled EMS, direct control of devices is forbidden due to the definition. So, possible data is:

- Tariffs (day-ahead, intraday, time-variable or load-variable)
 - For generation

- For consumption
- Short-term incentive, for example a Bonus for short-term reduction of electric loads
- Offers for short- to long-term energy supply contracts. This could be the case in some agent-based systems which incorporate an automatic contract conclusion.

3.2.1.5 Data exchange between local EMS's

In some agent-based approaches, local EMS's exchange information about contractual offers for energy supply or demand [Franke 2007]. This can be organized on a mid-time basis (contract duration typically 1 day) or short-time basis (contract duration lower than one second).

3.2.1.6 Data exchange between global EMS (DSO) and global EMS (Broker)

In some newer research approaches [Bendel 2007][Sebastian 2008], the global EMS is divided because of legal necessities, namely unbundling and market liberalization. But since energy management influences and gets influenced by both the broker's actions as well as the operational state of the grid, the two global EMS's typically have to exchange information as well. This can for example comprise planned device schedules for the next day, to be transmitted from broker to DSO in order for the DSO to check if the schedules lead to grid bottlenecks or other grid operation problems. The DSO eventually sends corrected schedules back to the Broker. This would be typical in a centrally organized EMS [Sebastian 2008]. Furthermore, the Broker, which knows of the technical abilities of the energy management system, can transmit information which relates to distribution-grid services offered to the DSO, for example grid supervision data, setpoints for local generators or loads or allowance for island mode operation of local EMS's and other [Bendel 2007].

3.2.2 Control with price signals or state of system signals?

Depending on the type of EMS chosen and the number of local EMS's, the amount of data to be transmitted can reach a point where usage of the ICT infrastructure gets very expensive or even technically impossible because of bandwidth limitation of the used ICT medium. For example, a centrally controlled EMS is not feasible to be operated if there are ten-thousands of local EMS's situated in the low-voltage grid. By using price signals or other incentives, the amount of data to be communicated can be greatly reduced. But on the other hand, the exact and direct control of all devices is lost that way. This disadvantage, however, can be accepted since it could be proven that the overall behaviour of devices controlled by local EMS's

using central information as incentives can be robustly predicted using historical data [Bendel 2007]. The ability of a decentrally organized EMS of indirectly controlling a very large number of small generators and loads, as they are typically distributed in the low-voltage grid, suggests a combination with a centrally organized EMS which only controls a small number of generators and loads with relatively high power, typically situated in the medium- or high voltage grid. Such a combination allows for a high number of devices to be included in the overall energy management while avoiding communications bandwidth problems.

3.2.3 General Communication Protocol Requirements

Communication: The basic requirements to establish a communication channel and exchange information between actors (nodes) are the *transmission media* and the *information model* itself. For exchanging meaningful data an agreed protocol (syntax) must be used, upon which the participants understand the transmitted content (semantic).

Protocol: The physical representation or media used is independent from the data exchanged – the data is mapped into the protocol. The most common standard definition of the different protocol layers is the ISO OSI seven-layer model [IEEE 2007]. Because of the agreements reached at various interacting parties, greater interoperability has been established.

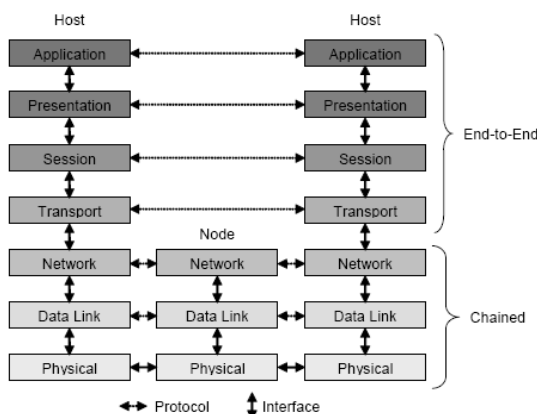

Figure 9: OSI reference model

Power network + Communication network

Smart Grids: The power system will transfer from the mostly passive operation into a more active network. This transmission is commonly known under the terminology Smart Grids. Parallel to the existing power network a communication network will evolve, which will enable the active control and operation through feedback from the end-nodes / consumers.

Reliability: Active control of DER relies on a sufficient performance of the communication network infrastructure. On the other hand, the communication / telecom network (ICT) massively depends on the power system. Regarding to a save and reliable *monitoring, information exchange and control* (MIC) the interdependencies of the power and information infrastructure must be reduced.

Costs: The high costs for establishing and operating dedicated MIC connections for small DER are critical to their participation in grid coordination. Sharing existing infrastructure (PLC, telephone, broadband and radio-links) will be a key to the convergence to smart grids, accepting the reliability cannot be as high as in dedicated communication lines, like in the transmission network or at large power plants.

Failures: In case of failures and blackouts the DER controller must operate in a predicted and intended way. If the PV / inverter / DER system is capable of sustaining an islanding operation (*microgrid*) than some emergency schedule plan should guarantee a safe operation. If the DER has to be disconnected from the grids due to non-islanding capability or safety reasons, a working communication infrastructure for remote controlling should be targeted (remain on-line controllable).

Fault ride through and reactive power supply: Recent interconnection guidelines ask for specific fault ride through behaviour in case of voltage sags (e.g. German Transmission Code 2007 [TRANS 2007]: stay connected during grid failures, supply short circuit current and control of reactive power supply).

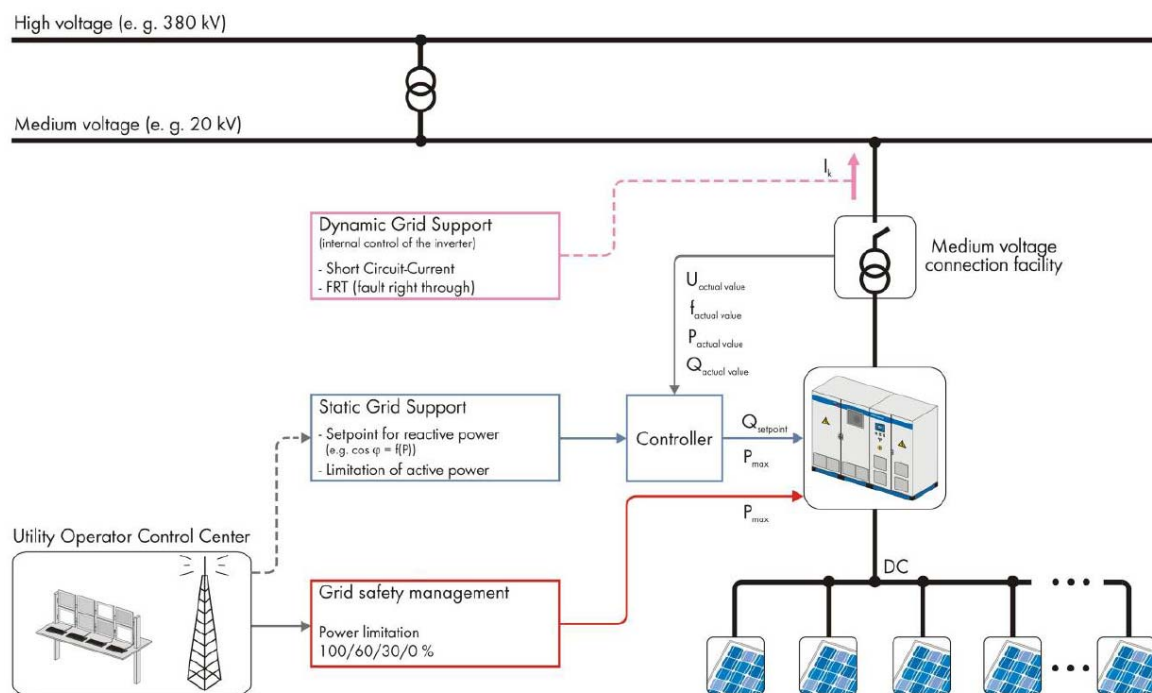

Figure 10: Simplified illustration of grid control using PV plants (medium-voltage grid) [SMA 2008]

Re-synchronization: After failures or blackouts, DER could help to re-establish normal grid operation or the system has to resynchronize to the grid. This could require some operation from the local DNO (central control) or presumes the automated (autonomous) operation of the DER unit.

Information model

Domain: To speak in the same language, someone has to define and agree on the same meaning: concepts, objects and the relationships between them. *Syntactically* and *semantically* the content and relations of the information must be defined to exchange information. The *ontology* is the formal representation of the set of concepts within a domain and the relationship between them.

Information model = standard services + object model + protocol profiles

[Com 2005]

IEEE: Information Exchange Agreement (IEA): Specifies the *interface*, *message definition* and *message content* supported between two transacting parties [IEEE 2007] (chapter 7). Similar to a protocol it explains the

- action / services of the interfaces,
- format of messages communicated,
- securing the interaction,
- message meaning - the ontology.

IEEE provides a framework – the IEA – to specify the requirements for interoperable interactions between DER.

DER-Controller

DER Controller: The unit that performs the monitoring and control function is called DER controller. It has to have some kind of interface to communicate and exchange information with the client and/or other controllers. These units may be on a different or at the same coordination hierarchy level depending on the control strategy – centralized or decentralized – and could be connected through gateway components.

The Local DER Controller is the *Logical Device* according to the IEC 61850 acting as “Server”, which provides data, responds to commands and manages the seamless operation of the DER device. It can be a simple electronic controller linked to a single device, a more capable Intelligent Electronic Controller (IED) providing additional functionalities, or a local server which manages multiple devices [DSM 2008].

The presence of a Local DER Controller becomes compulsory, in accordance with IEEE 1547.3, in case of a DER unit with 250 kVA or more rating or a DER installation at a single PCC with an aggregate rating of 250 kVA or more. In such occasions, the Local DER Controller provides for monitoring of information related to connection status, real power output, reactive power output and voltage at the point of connection [DSM 2008].

Interaction: In Figure 114 the oval entities represent the various stakeholders, who are involved in DER system transactions (one stakeholder can assume more than one role). All these stakeholders will interact with the Local DER Controller and among them via a public TCP/IP network, such as the Internet.

The internet has the advantage of interoperability (based on standard TCP/IP) and availability (hardware e.g. router devices). UDP can be used for more time critical communication, but also protocols for special purposes like in power system communication can be implemented (GOOSE and IEC 61850 GSSE – Generic Substation Status Event).

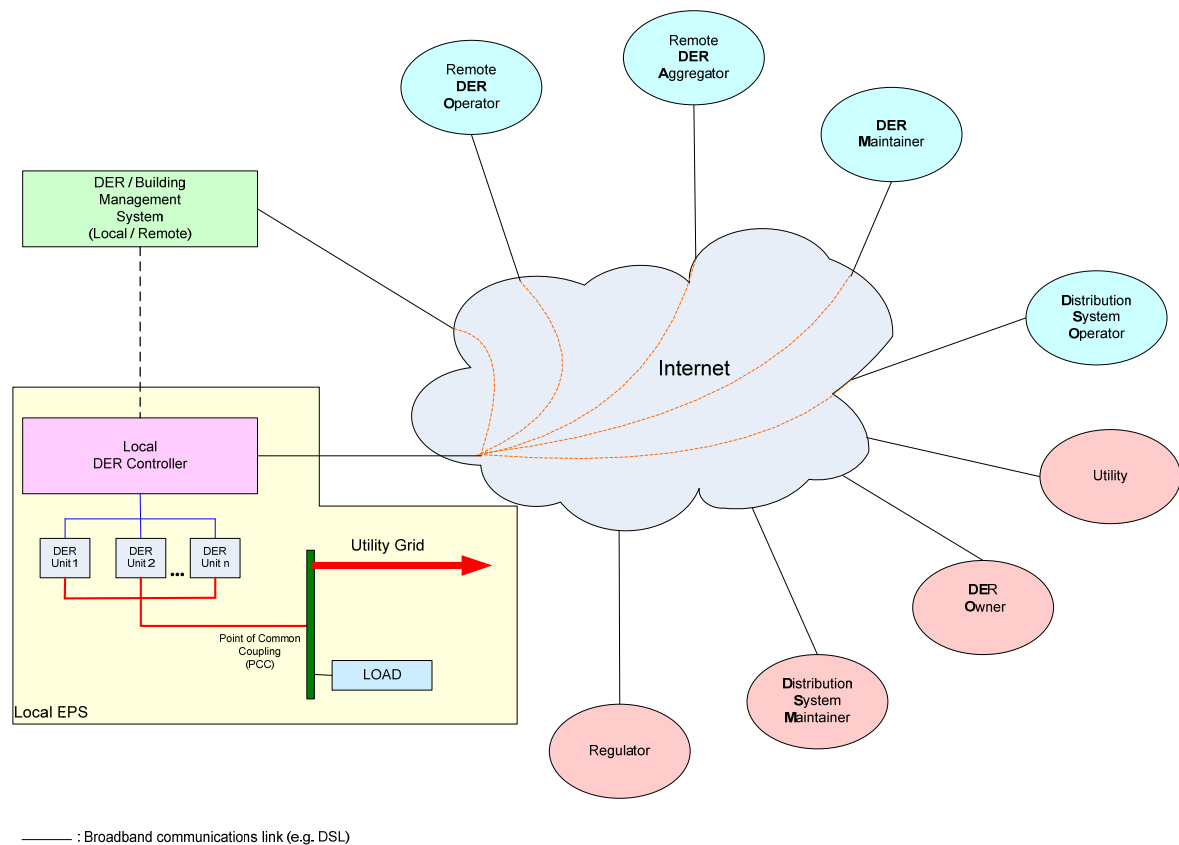

Figure 11: Example of the Communication System Architecture for DER [DSM 2008]

Terminologies: The controller unit has different names on several standardization efforts:

IED – Intelligent Electronic Device
UCA-DER Server / Client

IEEE 1547.3 DR-MIC Distributed Resource – Monitoring, Information exchange and Control

IEC 61850 → UCA according to EPRI

IEC 61850:

- LN: DRCT – DER local and/or Remote Controller
- LN: DCOV – DER Converter / Inverter
- LN: DPHV – DER Photovoltaics System

3.2.4 Communication technologies

The main technologies are [SmartA 2007]:

Power Line: Is a mature technology widely used to control power system assets. The advantages are the extensive coverage and the cost due to existing wire infra-

structure. The disadvantages are the high noise, capacity, open circuit problem and the lack of communication.

Internet: Advance in the technology (broadband) and coverage have enabled cost-effective monitoring and the access of remote devices. Disadvantages are the reduced reliability for real-time operation (Quality of Service – QoS) and the implied security concerns.

Public Telephone Network: Dedicated telephone lines are already used for reliable communication. Also the existing network can be used quickly and cost-effective. Disadvantages are the expenses for rented costs, the dependence on telecom companies. Also the time for (re-)establishing connections is only for not time dependent applications appropriate.

Satellite: High costs not only when it comes to bidirectional communication. The weather dependency and delay time for transmission are the beside the high-costs the disadvantages.

Optical Fibre: Has an extremely high bandwidth and therefore high performance, but is also expensive. Only for bundled high speed communication (backbones) it could be cost-effective operated.

Wireless: Some technologies are already used to control power system devices and have some advantages over conventional wired communication: Costs, when using existing cellular networks, rapid installation and flexibility. The disadvantages are the limited coverage, capacity and security issues.

Microwave: Operated normally in the frequency range between 150MHz to 20GHz. Have no particular advantage, but needs line of sight path, are subject to attenuation and have also capacity and security disadvantages.

3.2.5 Communication topology

One-way communication: Radio-link broadcast based communication is relatively cheap to implement and could also be very fast in terms of transmission to a large group of DER units (price signal). If it comes to differentiated response (e.g.: local disturbances) the one-way communication slows down due to addressing individual units, which could soon turn out to be costly and limited in bandwidth and of course lack of feed back to the control system.

Feedback and Coordination: Two-way communication enables the coordination and information exchange between DER units. It allows the (local or distributed) system controller to know the anticipated reactions to specific grid conditions, in opposite to passive operation.

Topologies and Information flow: Traditional *Client/Server* approaches have their strength in providing fast response to events which are sent from the client to the server. This way of communication could also be named as event-based: the clients push their information to the server or sending requests. *Master/Slave* resource management has the advantage of being simple to implement, but inter-slave com-

munication is often not possible. *Polling* the slaves from the master could soon be inefficient and slowly. The master normally pushes set, operate and get commands to the master. Information (reports) could be pushed from the slave under certain conditions.

3.2.6 Open standard / Interoperability / Interworkability

Open system: There are several efforts to produce international open-systems communication standards for power systems. The main advantages of such open standards are the free use and access – not only limited to a single domain – and the possibility to participate and extend it. For a fully integrated smart grid, a *universal standard* (for all users, vendors and operators) is needed.

Several categories were agreement and alignment must be achieved are needed to enable interoperability. The EICTA offers the following criteria for openness [EICTA]:

- Control: transparent evolution process of the standard
- Completeness: to ensure interoperability
- Compliance: standard-compliance offering promoted by the proponents
- Cost: fair, reasonable and non-discriminatory access to IP

Interoperability: The ability of two or more devices to communicate together in a system. This is achieved by standard protocols, definition of data and objects and standardized services (see: Information model).

Interworkability: The exchange of meta-data and the ability to support more "plug and play" – not only send and receive correct data, but also to understand and execute the messages. Often a higher standard of execution requirement (e.g.: "real time" control environment like *MMS – Manufacturing Message Specification*) is associated with this term [Hug 2007].

Versions and Upgrades: The ability to remotely update the information model represented by a piece of software makes it possible to keep the compatibility high over a longer period of the device life cycle. Changes and extensions to the existing specification or controller configuration can be done more easily. Although it makes the system more prone to security attacks, the maintenance and troubleshooting will be getting much cheaper with remote access.

Self-description / Configuration: One key to the interoperable grid would be a plug and play system architecture, which newly added systems *automatically configure* themselves and provide a self-description about their features and services they provide.

Configuration Description: The DER inverter is operating as a part of a (distribution) network, therefore it should fit into the larger distribution system information model. "IED Configuration Description" as part of the SSL / SCL: IEC 61850-6 description covers ICD, system configuration tools, SCD, IED tools and the IED. [Hoss 2007]

3.2.7 Performance and Reliability

Latency: For some applications and processes in the automation and control of DER units, the communication time between the sending and executing the command is critical. For instance from detection to tripping a protection devices, the "transition time" must be below a critical value (IEC 61850 dictates maximum end-to-end transfer time typically between 3-10 ms).

Throughput: The maximum, minimum and nominal amount of data which can be transported in the network is expressed in kilobits per second (Kbps). Error corrections and other overhead typically reduce the amount of raw data which can be transmitted.

Quality of Service: Fault detection and other fast response scenarios require a fast and reliable communication network. Especially when it comes to electric network faults, the communication network must be relied on for coordinated control and operation. In case of a power outage the communication network must keep operating.

Time and Time synchronization: Not only for time critical control, the exact synchronization of all participating devices is crucial to the operation of the system. Therefore a time synchronization mechanism must exist, typically done with time servers which broadcast time synchronization messages (e.g. Network Time Protocol NTP). All information exchange should include in their messages envelope the time stamps for exact report sequencing and for logging for later retrieval (history). *Priority Tagging* is used to separate time critical messages from normal bus load (see IEEE 802.1Q). Communication protocol standards for power systems use special protocols (IEC 61850 GOOSE and GSSE protocols) for time and safety critical communication.

3.2.8 Security and Privacy

Dangers: Open system architecture which use existing internet or telecom infrastructure to reduce cost and increase efficiency, are also prone to malicious attacks. All activities and interactions on the power system must be protected from attacks which could do harm to the business operations or the system reliability. At any point of local operation, the health of the larger system must be preserved.

Confidentiality: The exchanged information is held in a privately and only for the purpose of the business transacted. It is protected from unauthorized parties.

Integrity and Transaction: The received information is not altered. Transmission must be encrypted and protected from "man-in-the-middle" attacks. Transactions have a start and a clearly defined end. Any failure or interruption of the transaction process leads to a "roll back" of the actions done so far, thus to return to the last valid state before the transaction started.

Availability: The exchange is on a timely manner for the intended purpose.

Authorization: Different policies level of access must exist for the different roles of the users. This separates the simple user role from the system operator and more privileged roles.

Vulnerability: A large, global scale of same architectures can be threatened by attacks to single weaknesses of the system. Therefore changes to the standards must be validated before deployment to avoid this. On a local scale another threat could be a kind of "denials of service" attacks: link layer denial and association denial – requests from many clients could harm the operation of a server node. The system must be protected by direct access and illegitimate use in an unauthorised way.

3.2.9 Scalability and Extensibility

Scalability: Adding or removing units to the system must not influence system performance or reliability. DER units should integrate seamless to the grid, providing the services and data they offer to other units according to the access policies. According to the new grid topology and services the existing units could re-configure – evenly distribute tasks and controls.

Evolution: Compatibility with legacy standards is necessary for the upgrading of the system. The standard should be planned in advance with foresight for future requirements. Updating existing information models can increase the life cycle and can accelerate the transitions to newer and improved standards.

3.2.10 Hierarchy

Namespaces: Within the scope of a single level of hierarchy a unique namespace is used to address the devices.

Aggregation: DER servers are capable of managing multiple DER client devices in means of responsibility for their coordinated operation. The DER server works as one virtual representation of the DER units clustered. The aggregated units are normally on the same level of hierarchy.

Hierarchy: The hierarchy must be clearly defined to guarantee the reliable operation of the underlying system. With the increasing level of hierarchy often the responsibility and the importance of the device management is increasing. Even in a decentralized approach a certain level of hierarchy exists to hide the end devices beneath the local controller.

Centralized / decentralized control: The system can be coordinated from a central controller or from many decentralized approach by many autonomous controllers (e.g. agent based).

Levels of Control: In general the bus systems can be categorized in the *process bus*, which acquires field data from sensors and actuators, and the *station bus*, which allows functional operation within the station and external communication. Often supervisory control is defined as level atop of the others.

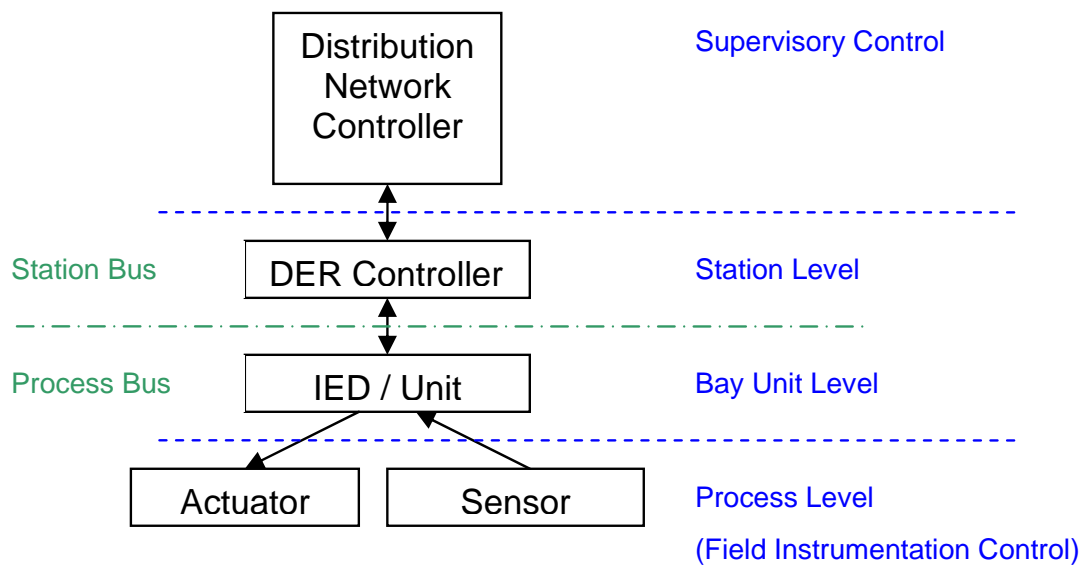

Figure 12: Level of controls

3.2.11 Standardization activity for DGs

List of automation and communication related standards for (distributed) power system:

- IEEE P1547.3
- IEC 61850 (and part 7-420 specific to DER)
- CIM – IEC 61970 – Common Information Model
- UCA / UCA-DER
- EPRI Electrinet
- IECSA – Integrated Energy and Communications System Architecture
- GridWise
- ANSI C12 Metering Protocols
- OPC-XML-DA – Data Access Specification

Web Technologies / Services (W3C, WSI, IETF) [EPRI 2004]

- XML
- SOAP
- WSDL
- WS-Security
- ebXML
- OWL
- DPWS

3.2.11.1 IEC 61850/IEC 618970

IEC 61850:

IEC 61850 is a standard for the design of electrical substation automation. IEC61850 is a part of the International Electrotechnical Commission's (IEC) Technical Committee 57 (TC57) reference architecture for electric power systems. The abstract data models defined in IEC61850 can be mapped to a number of protocols. Current mappings in the standard are to MMS (Manufacturing Message Specification), GOOSE, SMV, and soon to Web Services. These protocols can run over TCP/IP networks and/or substation LANs using high speed switched Ethernet to obtain the necessary response times of < 4ms for protective relaying.

Other mappings have been proposed but are not yet standardized as is the case of the ACSI-CORBA mapping.

Multiple protocols exist for substation automation, which include many proprietary protocols with custom communication links. Interoperation of devices from different vendors would be an advantage to users of substation automation devices. An IEC project group of about 60 members from different countries worked in three

IEC working groups from 1995. They responded to all the concerns and objectives and created IEC 61850. The objectives set for the standard were:

1. A single protocol for complete substation considering modeling of different data required for substation.
2. Definition of basic services required to transfer data so that the entire mapping to communication protocol can be made future proof.
3. Promotion of high interoperability between systems from different vendors.
4. A common method/format for storing complete data.
5. Define complete testing required for the equipments which confirms to the standard.

IEC 61970:

The IEC 61970 series of standards defines the set of technologies required to enable the integration of control centre applications. IEC 61970 is based on a previous work done by EPRI Control Center API (CCAPI) research project (RP-3654-1). The CCAPI project aimed to enable the easy integration of applications in EMS environments and improve data exchange features, both internal and external. The proposed solution should cover architecture, data model and be completely independent from the underlying technology. The specification resulting from IEC 61970 shares the same objectives:

- Enable the integration of multi-vendor applications.
- Allow the exchange of information to systems outside the control centre.

It is worth mentioning that the scope is not limited to transmission systems; it also includes distribution and generation systems exchanging real time data.

Although the IEC 61970 series of standards is far from being complete the CIM is receiving a significant growing support from leading manufacturers. On the one hand EMS/DMS/SCADA manufacturers come into effective use of the standards paving the way to followers while on the other hand standard gaps, pending issues and errors are identified and solved. A second source of support is envisioned at the Large Scale Power Grid Operators (LSVPGO) association formed by Transmission System Operators (TSO).

All classes in CIM are grouped together into packages depending on their role within the power system.

CIM contains eight main packages, and a global domain package used for defining data types. The Core, Wires and Topology packages contain all the basic classes for defining the physical characteristics of a power network.

The Wires package include classes that are used to represent the electrical components of a network, such as Transformers, Lines and Switches, while the Core and Topology packages define the interconnection of components.

3.3 Conclusions

The Communication and Control Concepts for Operation of Inverters for Future Power Systems are presented in this chapter. Inverters are assumed as black boxes and the communication is realised by their inputs and outputs. One of the attractive results adopted in this chapter is that the standardization needs for communication are satisfied partially by the IEEE 1547-2003 standard and IEC-61850-7-420 Committee Draft for Vote. IEEE 1547-2003 establishes criteria and requirements for interconnection of Distributed Resources (DR), with Electric Power Systems (EPS). This standard provides a uniform standard for interconnection of distributed resources with electric power systems. It provides requirements relevant to the performance, operation, testing, safety considerations, and maintenance of the interconnection.

More specifically, the IEEE 1547.3 standard remarks that the Inverters listed and labelled in compliance with UL 1741 [B61] include verification that they pass a non-islanding test in conformance with IEEE 1547.1 standard. If the local electric power system (EPS) de-energizes, this type of inverter will cease to energize the local and area EPS. This type of inverter needs to sense the voltage and frequency so the distributed resources (DR) will promptly cease to energize the area EPS during an outage and **re-synchronize** when power is restored in compliance with IEEE 1547.1 standard.

Apart from the **re-synchronization** communication requirements, which are covered by the IEEE 1547 standard, the General Communication Protocol Requirements are covered by the 1547.3-2007 standard. The concepts which are covered by this standard are: **Communication Topologies, Open Standard (Interoperability/Interworkability), Performance, Reliability, Security, Privacy, Scalability, Extensibility and Hierarchy**. Moreover, the 1547.3 standard can accomplish the **Centralised versus Decentralised Control** Concepts. However, the above mentioned concepts are expected to be modified for operation of inverters in future power systems.

The scope of the IEC 61850 Part 7-420 Committee Draft for Vote (CDV1) is the specification of the object models of DER information that can be exchanged between DER devices and any systems which monitor, control, maintain, audit, and generally operate DER devices. It is noted that object models are standardized formats or templates for exchanging data between different equipment or systems.

According to IEC 61850 Part 7-420 CDV1, the inverter/converter logical device could includes:

- The characteristics of the rectifier, which converts generator output AC to intermediate DC

- The characteristics of the inverter, which converts DC to AC
- Measurement of intermediate DC
- Measurement of input AC
- Measurement of output AC

Furthermore, the combination of IEEE 1547-2003 standard with the IEC 61850 Part 7-420 CDV1 could be the basis for standardization of the non standardised concepts, which are the followings: ***Energy Management Systems (EMS), Demand Management Systems (DMS), Demand Side Management (DSM), Generation Control, Demand Control, Ancillary Services, Interfacing structure for smart and multi-metering, Price Signals Markets, Multi Agent Systems, Black Start, Primary and Secondary Control, Voltage Control, PF and QV Droop.***

3.4 List of Standards

The following table lists the standards which are most relevant according to inverters and communication and control.

Standard(s)	Title	Stage
IEEE 1547 (Part 3)	IEEE Standard for Interconnecting Distributed Resources with Electric Power Systems	Published
IEC 61850	Basic communication structure for substation and feeder equipment	Published
IEC 61850-7-420	Communications systems for Distributed Energy Resources (DER) - Logical nodes	Draft
IEC 60146	Semiconductor convertors	Published
IEC 62103	Electronic equipment for use in power installations	Published
UL 1741	Inverters, Converters, and Controllers for Use in Independent Power Systems	Published
IEC-EN 60870-5-102	Telecontrol equipment and systems – Part 5: transmission protocols – section 102: companion standards for the transmission of integrated totals in electric power systems	Published
IEC-EN 62056	Electricity metering – Data exchange for meter reading, tariff and local control	Published
IEC-EN 61334-4	Distribution automation using distribution line carrier systems – Part 4: Data communication protocols	Published

3.5 Literature

[Taylor 2002] P. Taylor, D. Rollinson, I. Williamson, 2002, “Self Tuning Intelligent Load Control for the Stable and Efficient Integration of Wind into Stand Alone Electrical Power Systems”, *Global Windpower*, Paris, France

[Bendel 2007] C. Bendel, D. Nestle, J. Ringelstein: Bidirectional Energy Management Interface (BEMI) Integration of the low voltage level into grid communication and control, 19th International Conference on Electricity Distribution, Wien, 05/2007

[Franke 2007] M. Franke, A. Kamper, A. Eßer: Pricing Energy in a Multi-Utility Market, in: *Advances in Data Analysis: Proceedings of the 30th Annual Conference of the German Classification Society (GfKI)*, Springer, S.433 – 440, 2007

[Sebastian 2008] M. Sebastian, J. Marti, P. Lang: Evolution of DSO control centre tool in order to maximize the value of aggregated distribution generation in smart grid. CIRED Seminar 2008: SmartGrids for Distribution, Frankfurt, 06/2008

[Hoss 2007] Luc Hossenlopp, Engineering Perspectives on IEC 61850, IEEE power & energy magazine, may/june 2007

[Com 2005] Communication Standards for Future Integration of Energy Resources, EPRI Fact Sheet, July 2005

[GridWise 2008] GridWise Interoperability Context-Setting Framework, The GridWise Architecture Council, March 2008

[VDN 2004] IEC 61850 – Anforderungen aus Anwendersicht – VDN, Juli 2004

[DOLE 2005] Dave Dolezilek, IEC 61850: WHAT YOU NEED TO KNOW ABOUT FUNCTIONALITY AND PRACTICAL IMPLEMENTATION, Schweitzer Engineering Laboratories, Inc, USA, 2005

[ILLI 2007] Jinanqing Zhang, IEC 61850 – communication networks and systems in Substations: An Overview of Computer Science, Illinois Security Lab, 2007

[IEEE 2007] IEEE 1547.3: IEEE Guide for Monitoring, Information Exchange, and Control of Distributed Resources Interconnected with Electric Power Systems, IEEE Standards Coordinating Committee 21, 2007

[UCA 2003] E2I and EPRI, Utility Communications Architecture® (UCA), Object Models for Distributed Energy Resources (UCA-DER), Version for IEC TC57, Draft, Oct. 2003

[EPRI 2004] EPRI The Electrinet: A Communications Architecture for a Competitive Electric, Power Industry, Functional Specifications, March 2004

[Hug 2007] Hughes, J.; Interworkability: The Key Ingredients; Grid-Interop Forum, EPRI, 2007

[DSM 2008] Kärkkäinen, S. et al., State of the Art Report, , IEA-DSM Task XVII: Integration of Demand Side Management, Distributed Generation, Renewable Energy Sources and Energy Storages, 2008

[EICTA] European Industry Association, Information Systems Communication Technologies Consumer Electronics "EICTA Interoperability White Paper," 21 June 2004

[IEC 61850-1] IEC 61850-7-1: Communication networks and systems in substations - Part 7-1: Basic communication structure for substations and feeder equipment - Principles and models

[SmartA 2007] Smart A – D4.3.: A Working Document on communication and Control Requirements, Smart Domestic Appliances in Sustainable Energy Systems, Intelligent Energy Europe, 2007

[Good 2007] F. R. Goodman, IEC TC57, WG17 – Distributed Energy Resources and Distribution Circuit Automation – Overview of Purpose and Scope, 2007

[TRANS 2007] Transmission Code 2007, Netz- und Systemregeln der deutschen Übertragungsnetzbetreiber. VDN, August 2007

[SMA 2008] V. Wachenfeld, PV Inverters Supporting Electrical Grid Stability Through Active and Reactive Power Control, SMA Solar Technology AG, 23rd European Photovoltaic Solar Energy Conference, Valencia 2008.