

EES-UETP Course title

Review of Conventional Distribution System Protection

Dr Campbell Booth
University of Strathclyde

Distribution System Protection: Overview

- Typical distribution network architectures
- Protection basics and requirements (review)
- Brief review of protection philosophies and schemes:
 - Unit/non-unit
 - Differential/distance/overcurrent
 - Reclosers/Sectionalisers/Fuses
- Summary of operation and setting of distribution protection
- Practical considerations



Transmission & Distribution Architecture

Gers and Holmes
 "Protection of Electricity Distribution Networks",
 IEE Power & Energy Series 47

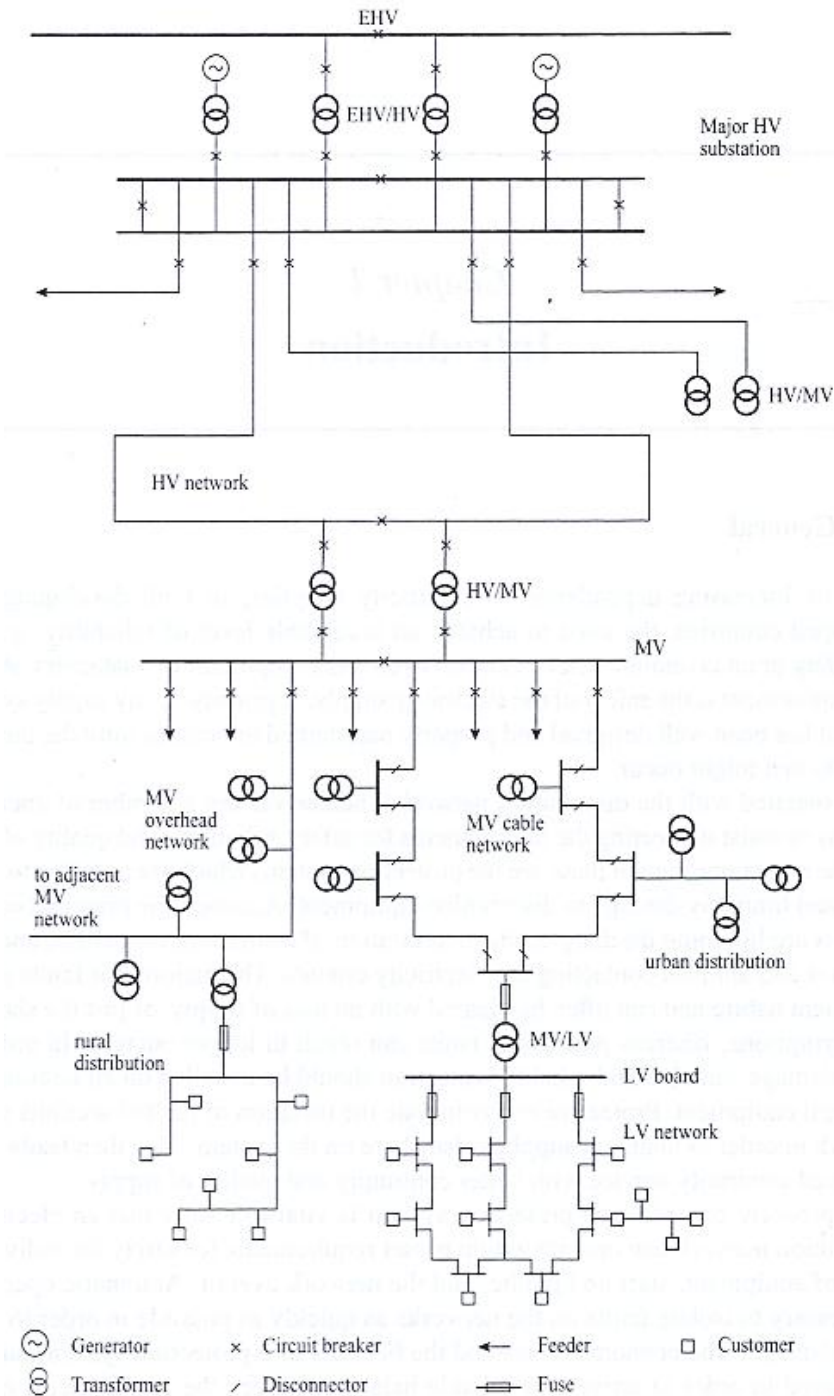

Protection Zones

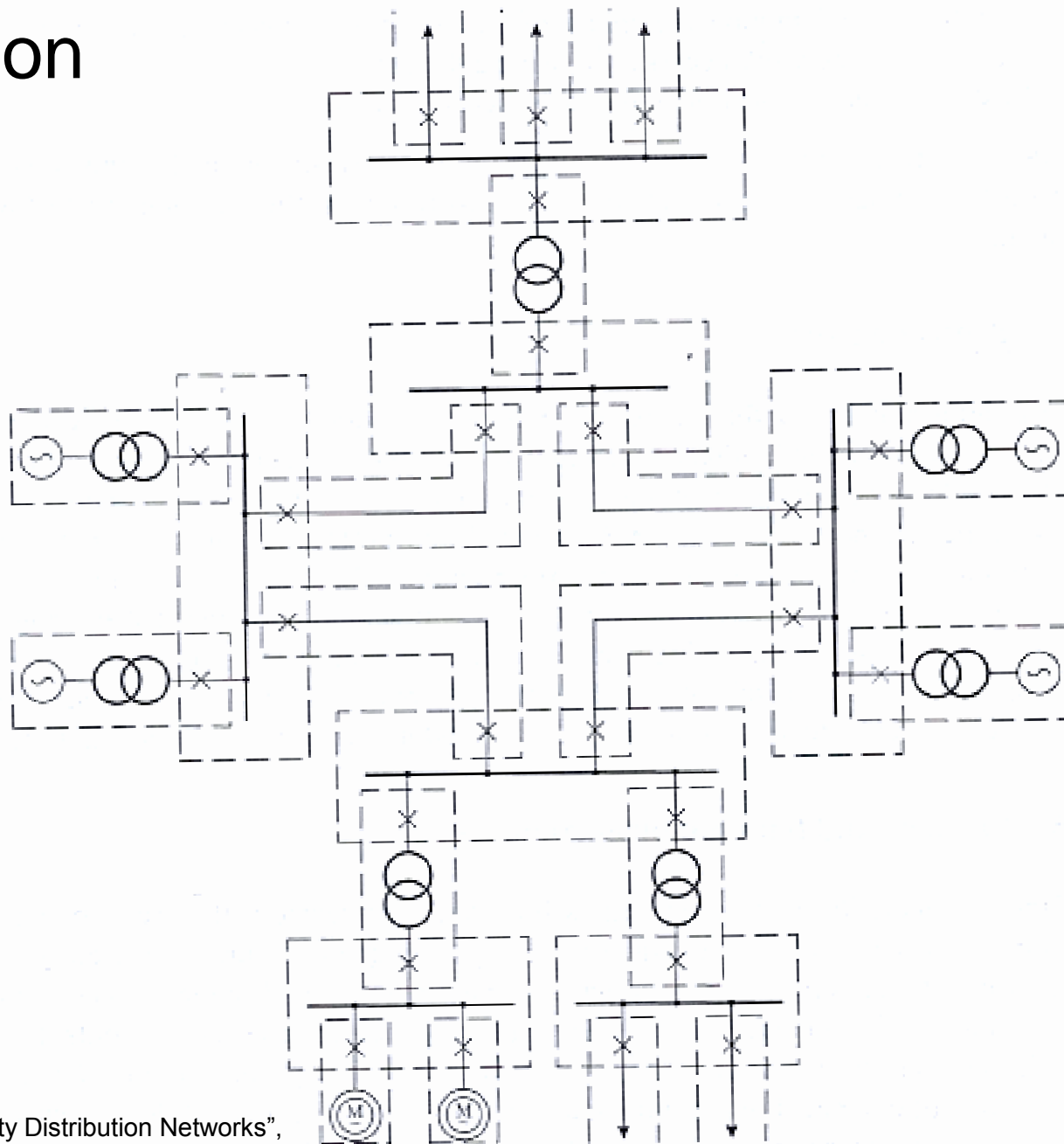

Gers and Holmes
"Protection of Electricity Distribution Networks",
IEE Power & Energy Series 47



Electrical Arc

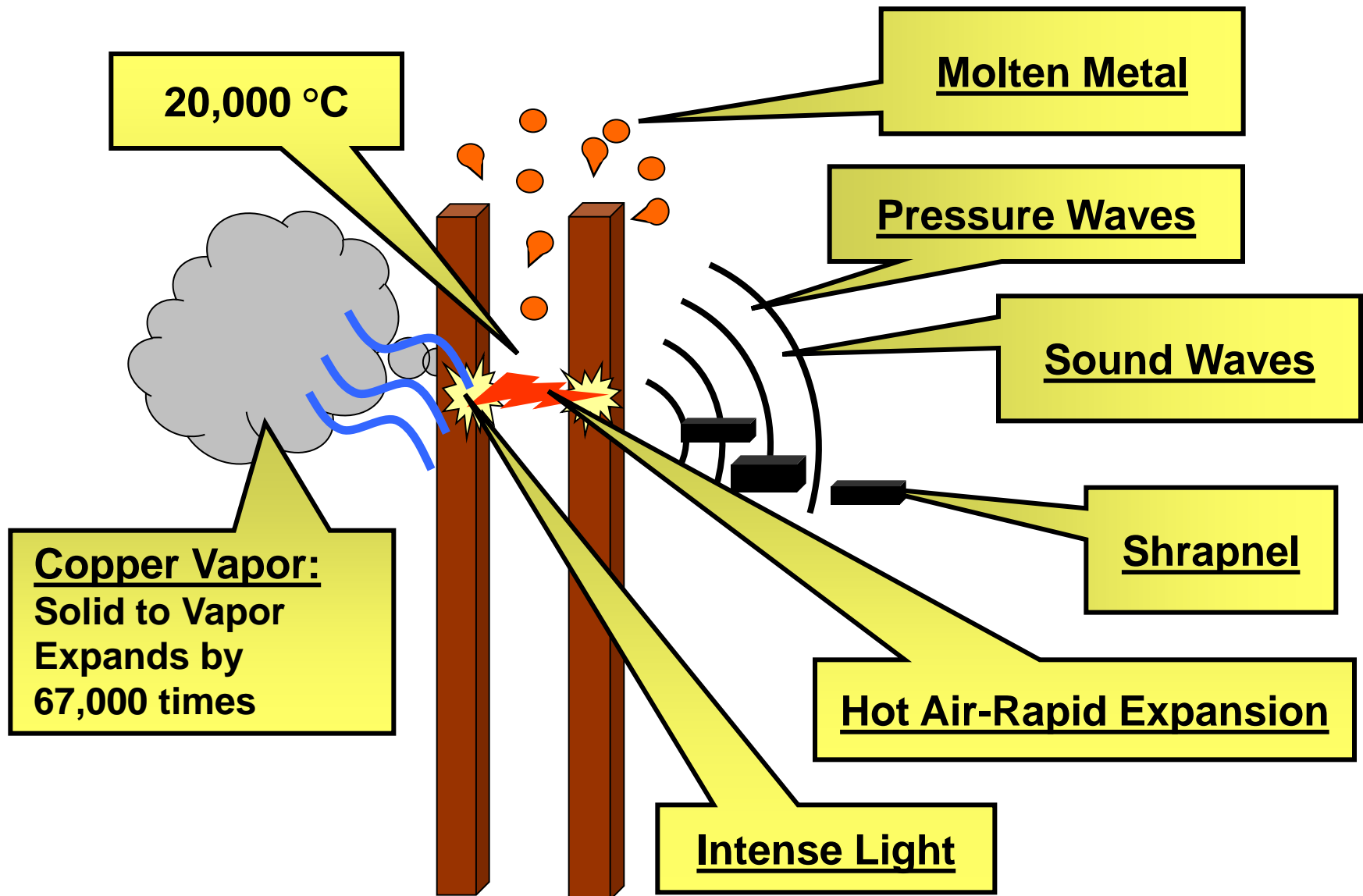

Faults on power systems

- Faults on power systems
 - (Usually) characterised by large fault currents
 - Fault current level usually drops with distance away from source due to impedance of lines/transformers in the network
 - Large voltage depression around the point of fault (load impedances shorted)



Power System Protection - How?

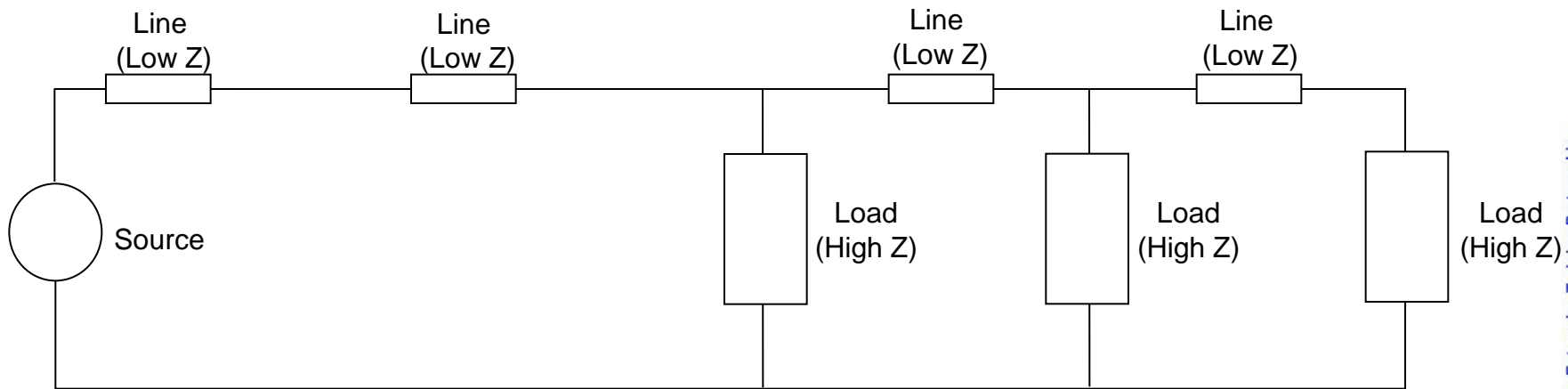

Typical section of power system – one line diagram



Power System Protection - How?

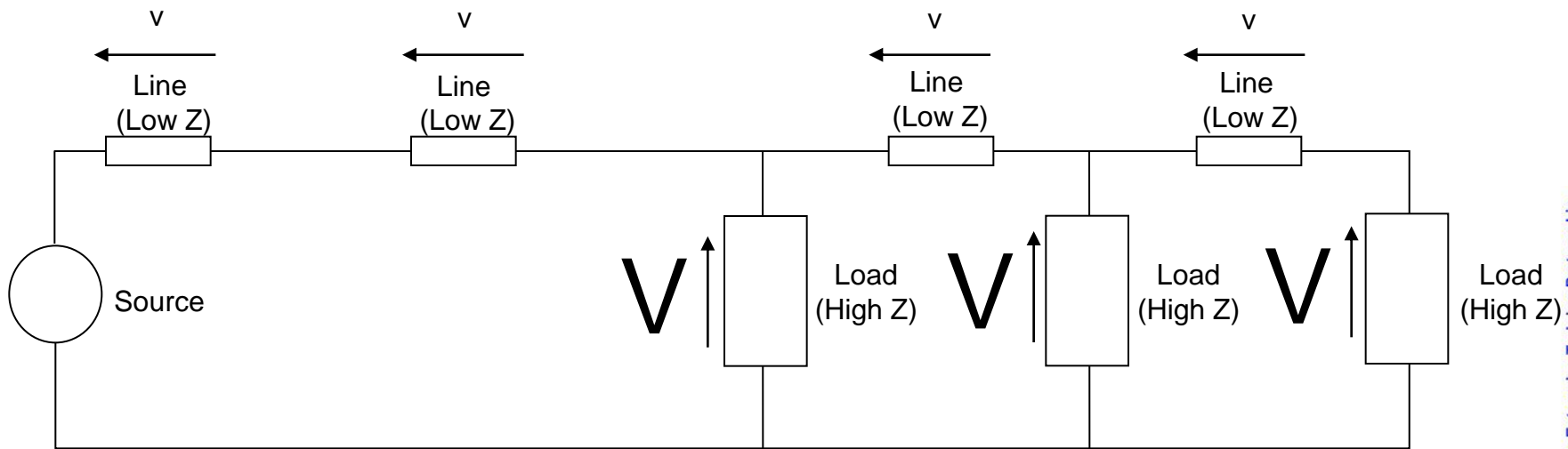

Typical section of power system – one line diagram

Power System Protection - How?

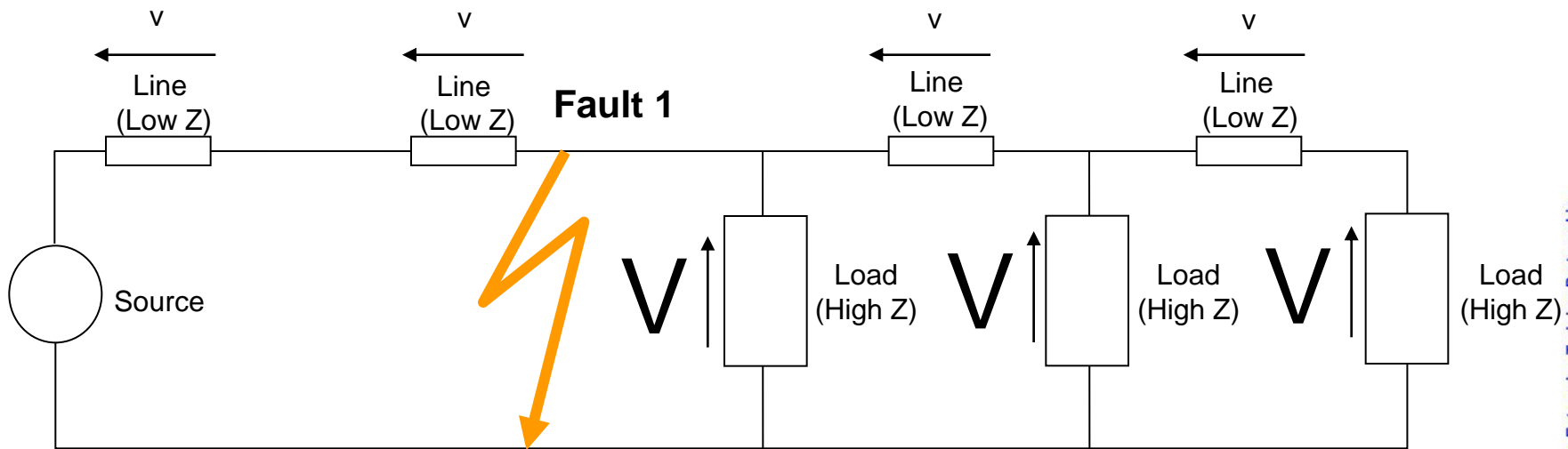

Typical section of power system – one line diagram



Power System Protection - How?

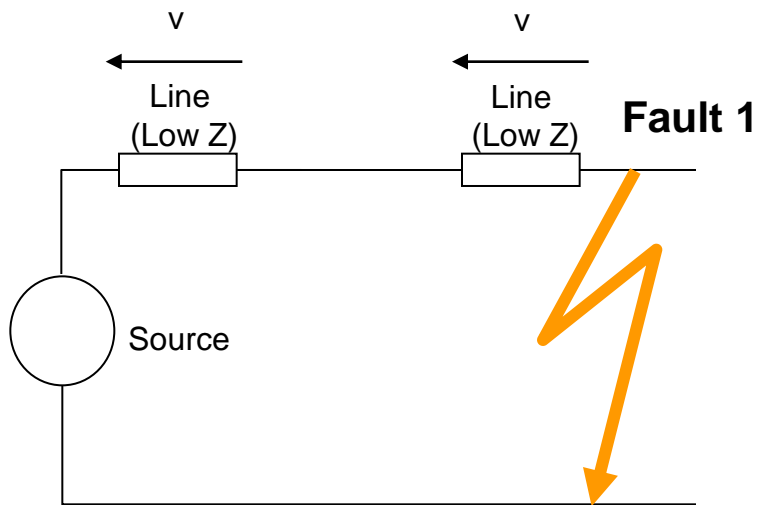

Typical section of power system – one line diagram



Power System Protection - How?

Current much higher than load current
Voltage at fault = 0

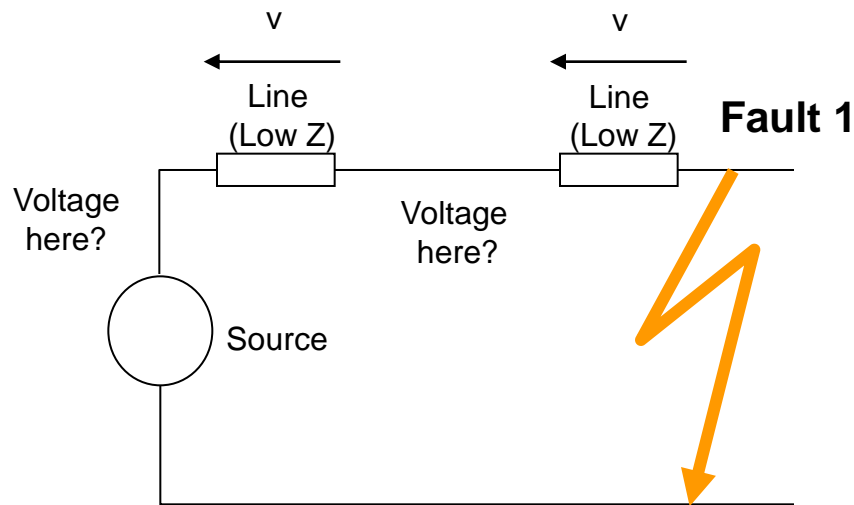

Typical section of power system – one line diagram



Power System Protection - How?

- Measurement of current (and often voltage) at many locations:
 - Fault current flow usually lessens in magnitude as fault distance from source increases
 - Voltage at a measurement point usually increases as fault distance from measurement point increases



Power System Protection - How?

Current much higher than load current
Voltage at fault = 0

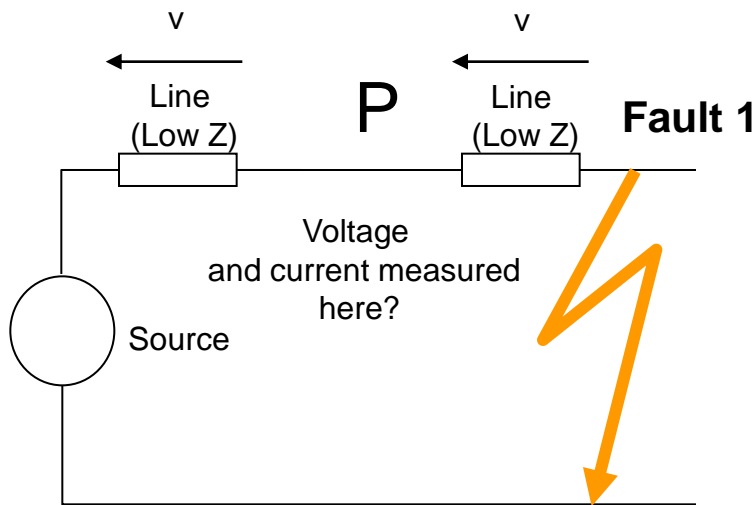

Typical section of power system – one line diagram



Power System Protection - How?

Current much higher than load current
(but not as high as fault at position 1)
Voltage at fault = 0

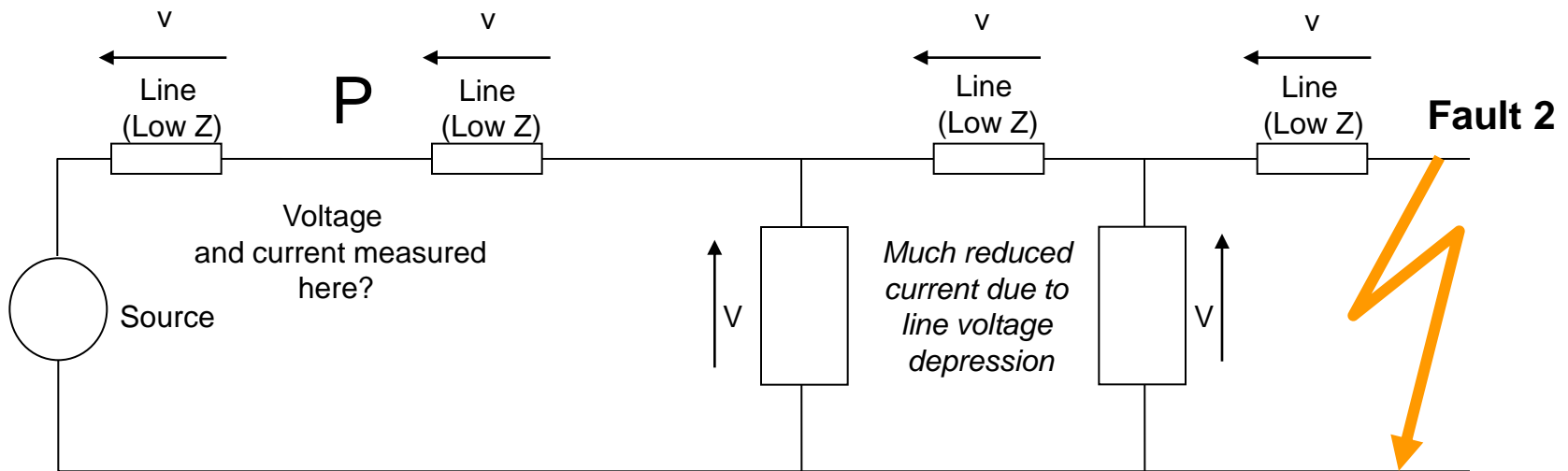

Typical section of power system – one line diagram



Factors affecting fault severity

- Magnitude of fault current
 - How much and what nature of generation is on the system
 - How “close” generation is to fault position – impedance to fault
 - Power system configuration
 - Nature of fault
 - Earthing arrangements (only applicable for particular types of fault)
- Duration of fault



Protection System Requirements (1)

- The protection systems must:
 - rapidly and automatically disconnect the faulty item(s) of plant or section of the power network;
 - minimise the disconnection of “healthy” plant, thus ensuring maximum security of supply to consumers.



Protection System Requirements (2)

- The degree to which any protection system satisfies the aforementioned requirements can be described by four inter-related parameters - **discrimination, sensitivity, operating time and stability.**



Protection System Requirements (3)

- **Discrimination** is the degree of ability of the protection system to select whether or not to operate for a given measured system state.
- **Sensitivity** is a measure of the ability of the protection system to identify the presence of fault or other undesirable condition, even though that condition may be only slightly different from an apparently healthy condition



Protection System Requirements (4)

- **Operating time** is the total time taken from the onset of the fault to the protection relay sending a trip signal to the circuit breaker(s).
- **Stability** is a measure of the ability of the protection system to remain inoperative under certain fault conditions, because the fault is of such a nature that some other protection system is intended to effect tripping.



Protection Philosophies

- Two major protection philosophies
 - **unit** schemes should only detect and react to primary system faults within the zone of protection, while remaining inoperative for external faults;
 - **non-unit** schemes do not independently protect one clearly defined part (or zone) of the system - adjacent non-unit protection schemes on an interconnected power system have an element of “overlap” with respect to their respective zones of protection.



Unit Protection Schemes

- Measurements/comparisons of quantities
- React only to faults inside protected zone
- Employs communications - expensive
- Remain stable for external faults
- No backup for neighbouring system



Unit Protection: Normal Conditions

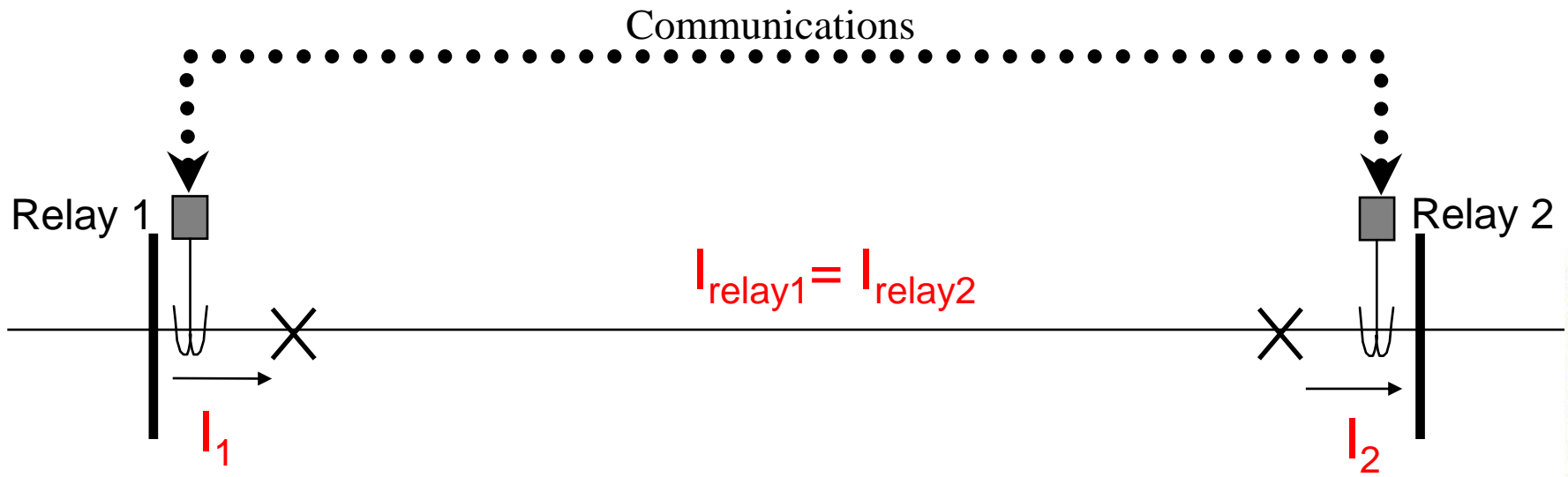

Unit Protection: Internal Fault

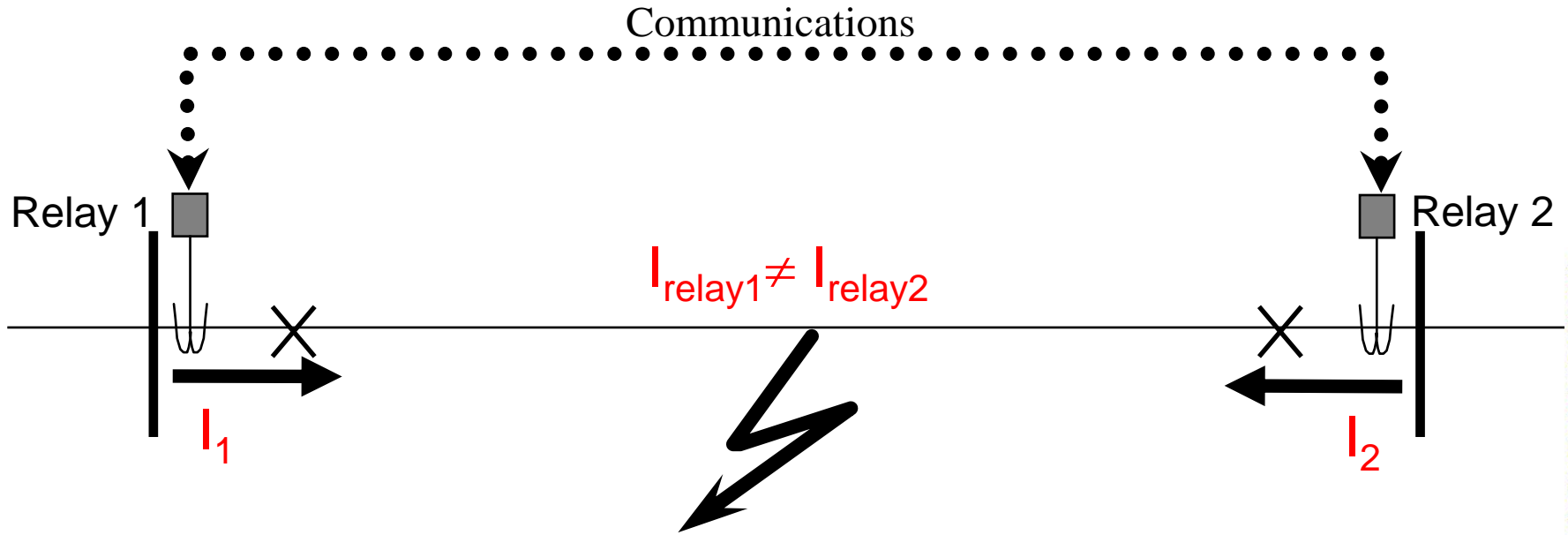

Unit Protection: Internal Fault



Unit Protection: External Fault

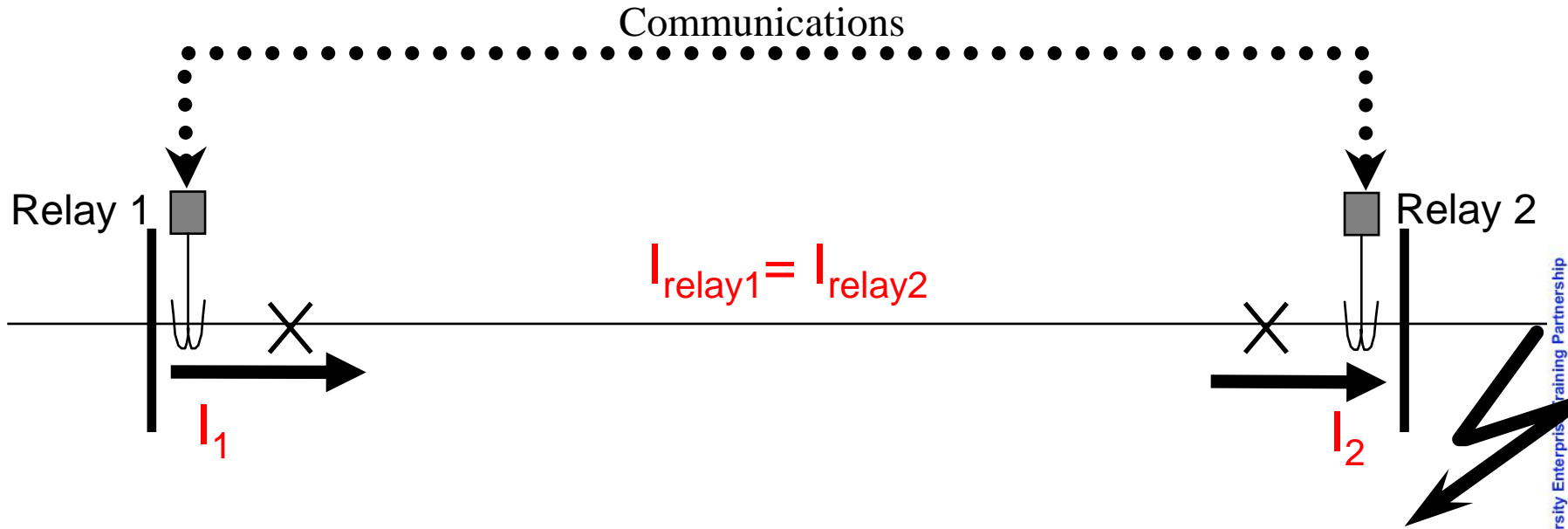

Unit Protection Schemes

- Examples:
 - Current differential protection
 - Phase comparison protection
 - Balanced voltage protection
 - Fault-generated noise protection
 - Distance protection with zone 1 inter-tripping



Non-Unit Protection Schemes

- Do not independently protect one clearly defined part (or zone) of the system
- Non-unit protection schemes “overlap” with respect to their zones of protection - provides backup
- Settings are important to ensure discrimination and stability
- Communications sometimes used to enhance operation



Non-Unit Protection

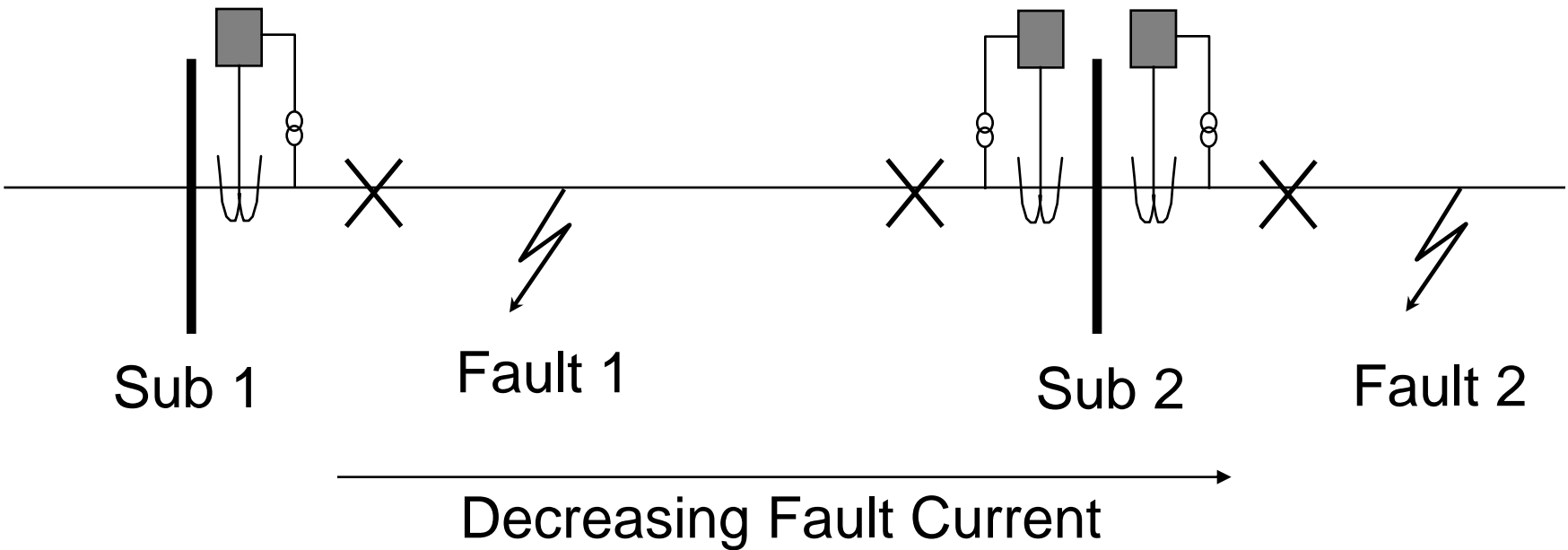
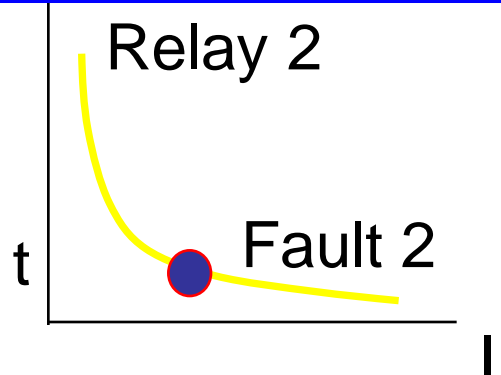
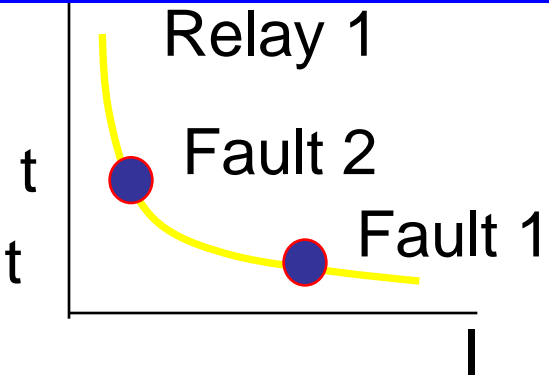

Non-Unit Protection Schemes

- Examples:
 - Overcurrent schemes
 - Measure current
 - Distance/impedance measuring schemes
 - Measure voltage and current



Unit/non-unit protection

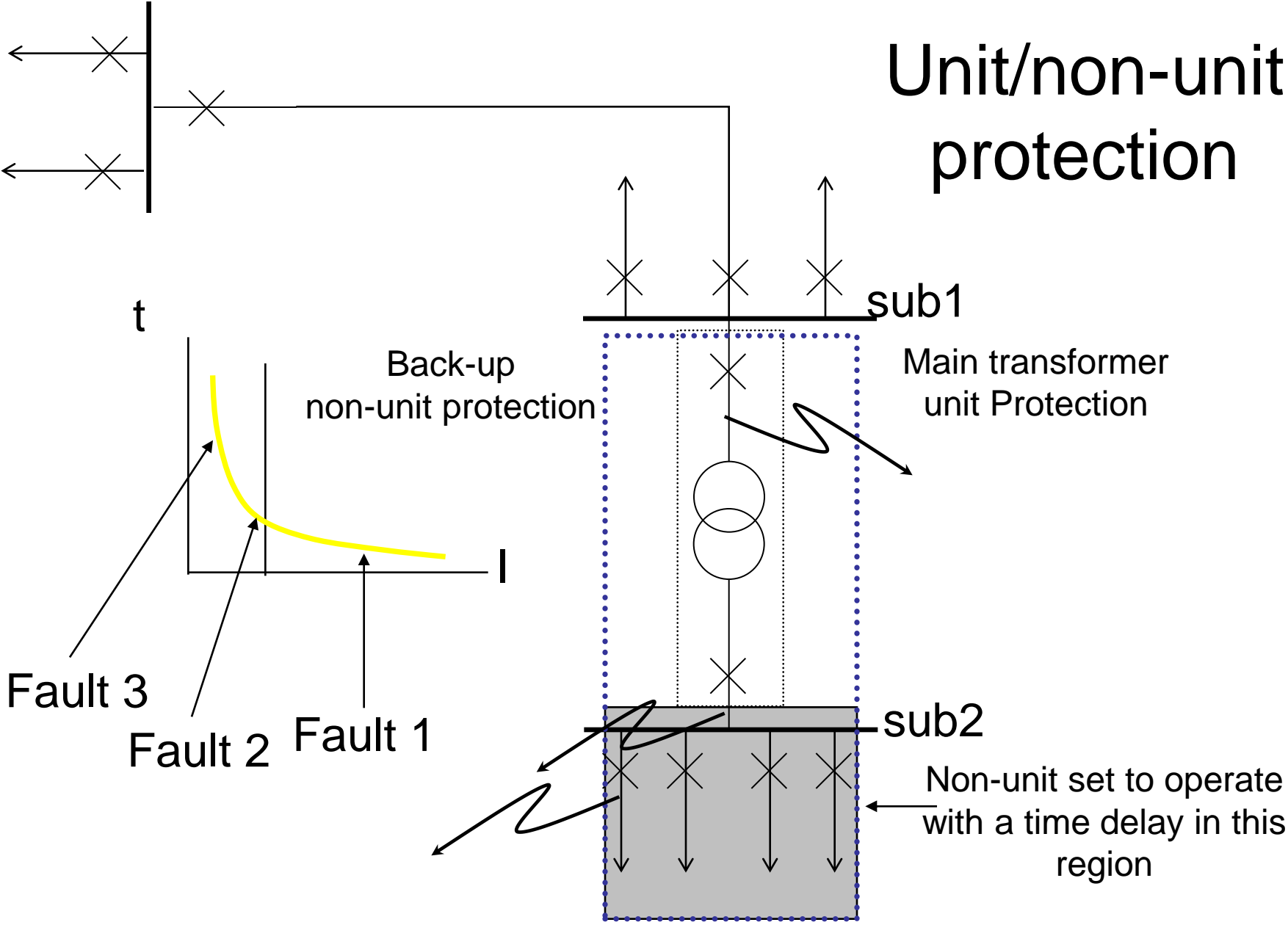

Distance Protection

Current much higher than load current
Voltage at fault = 0

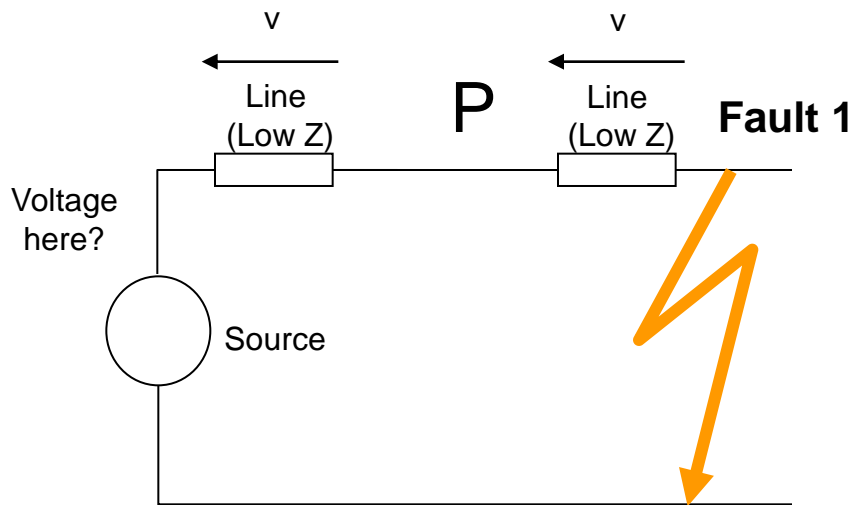

Assuming all line Zs are equal
Voltage at P = $0.5V_{\text{source}}$
Fault current = X



Distance Protection

Current much higher than load current
(but not as high as fault at position 1)
Voltage at fault = 0

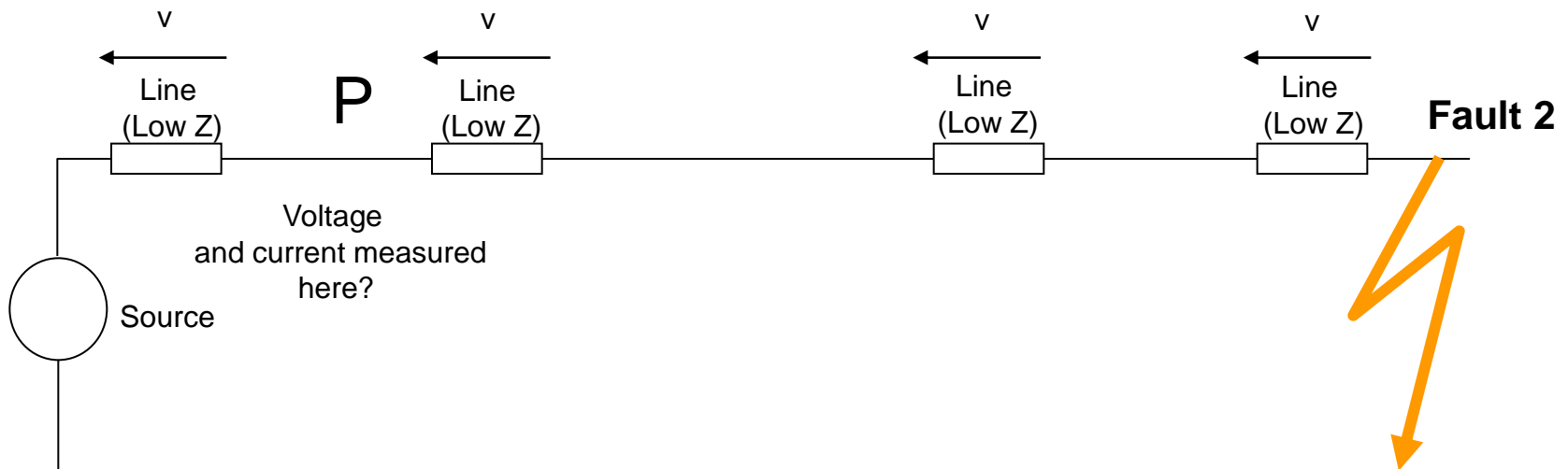

Assuming all line Zs are equal
Voltage at P = $0.75V_{\text{source}}$
Fault current = $0.5X$



Distance Protection

- Measures voltage and current
- Faults further away from measurement point
 - V relatively high
 - I relatively low
- Faults nearer to measurement point
 - V relatively low
 - I relatively high



Distance Protection

- System is set to operate for certain ratios of V , I
 - Can react with different time delays (e.g. as fast as possible for close faults, slower (backup) for further away faults)

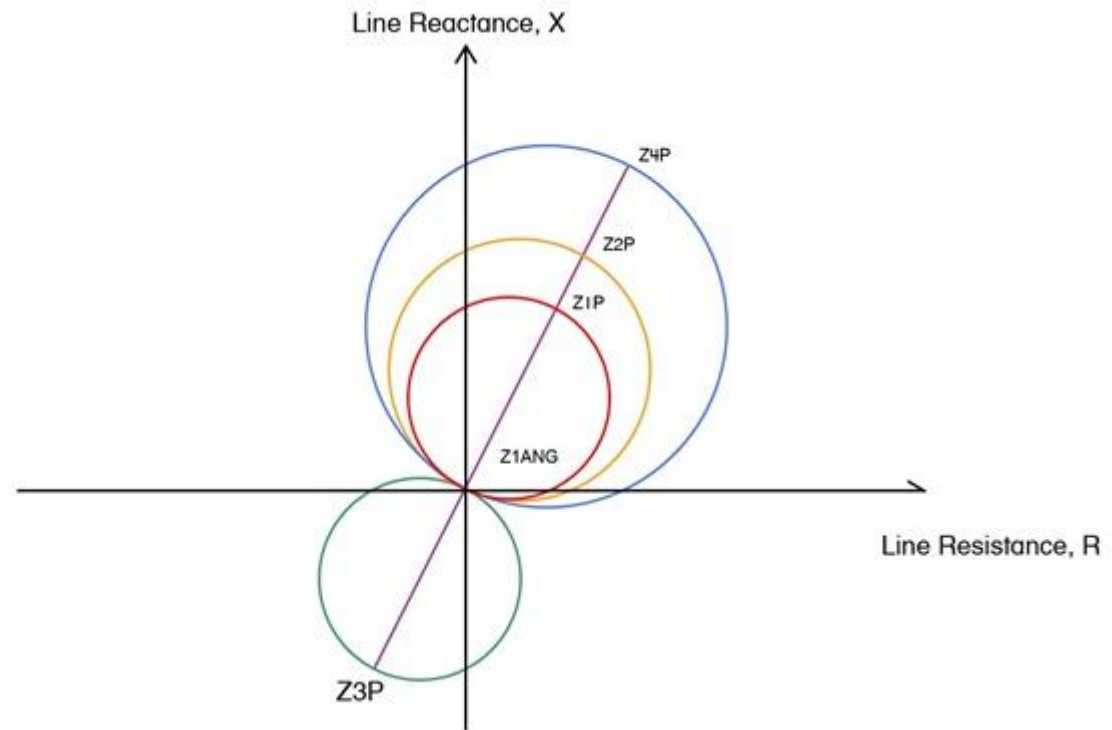

Overcurrent Protection

- Inverse characteristic
- Used as main protection in distribution networks, backup in transmission networks
- Provides different time of operation depending on level of fault current

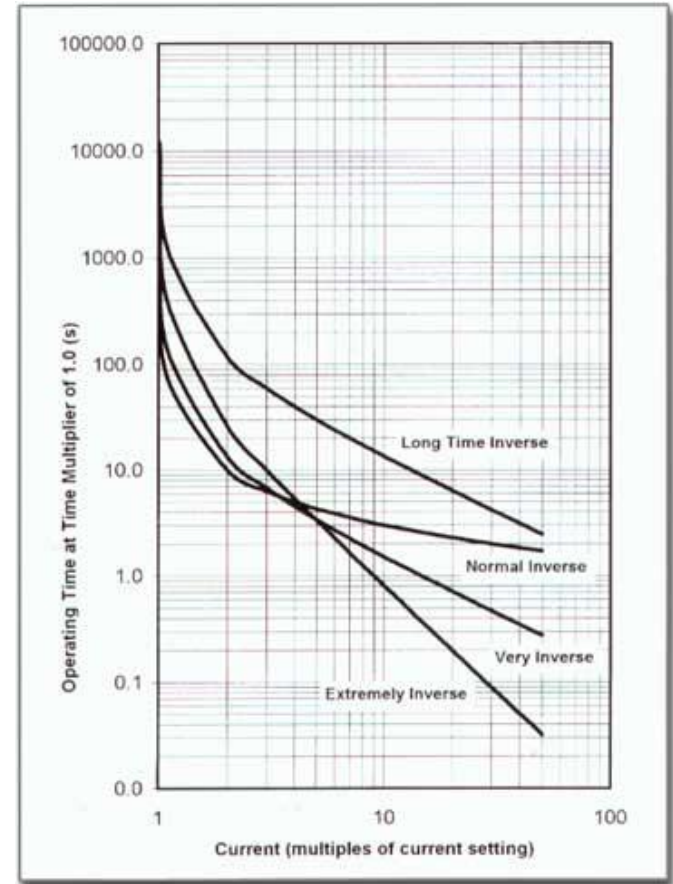

Time setting

Restraining spring

Disc

Plug setting

Core (carries flux)

Relay contacts

Shadin rings (introdu phase sh

Conta make

Induction Disc Relay

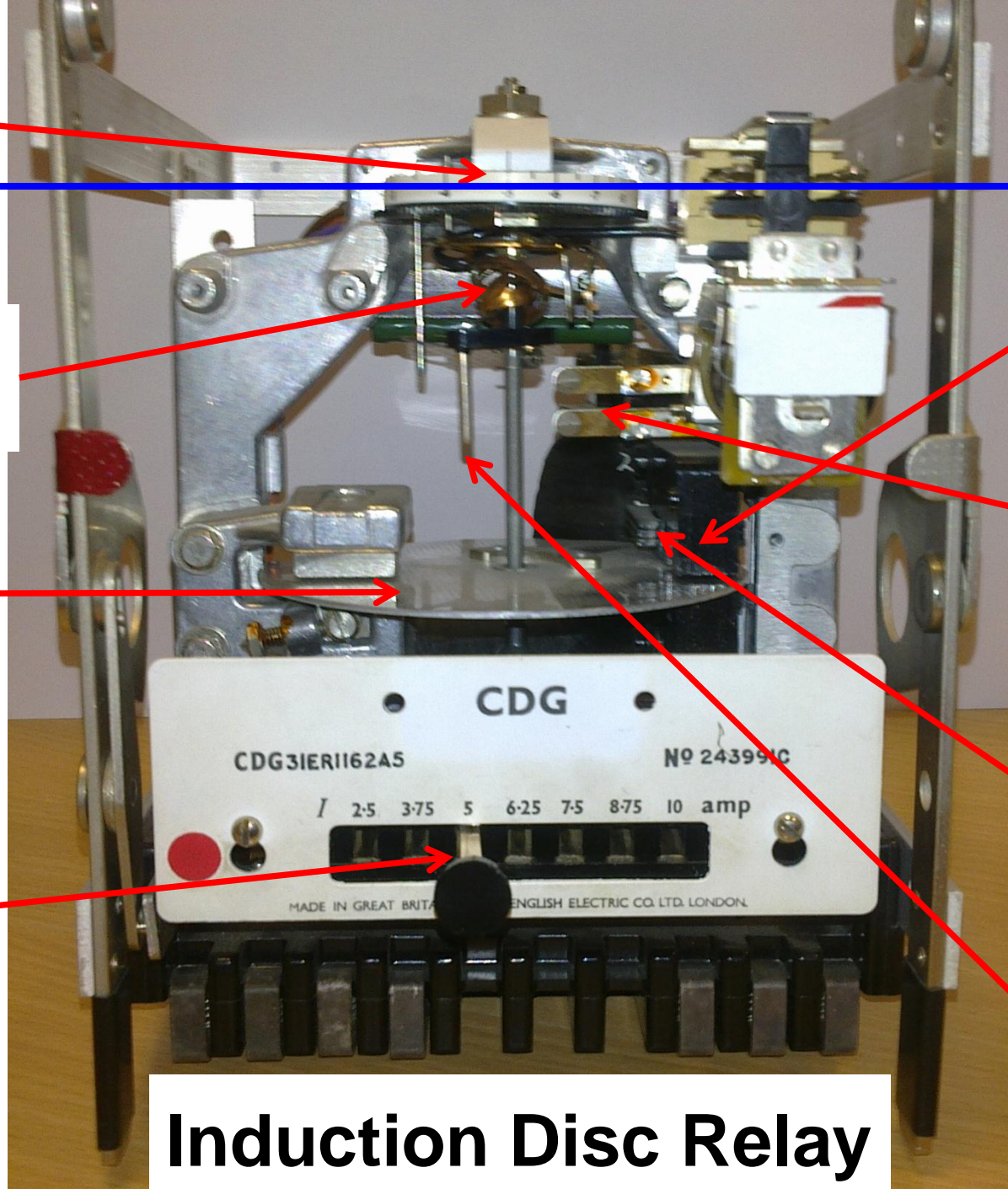

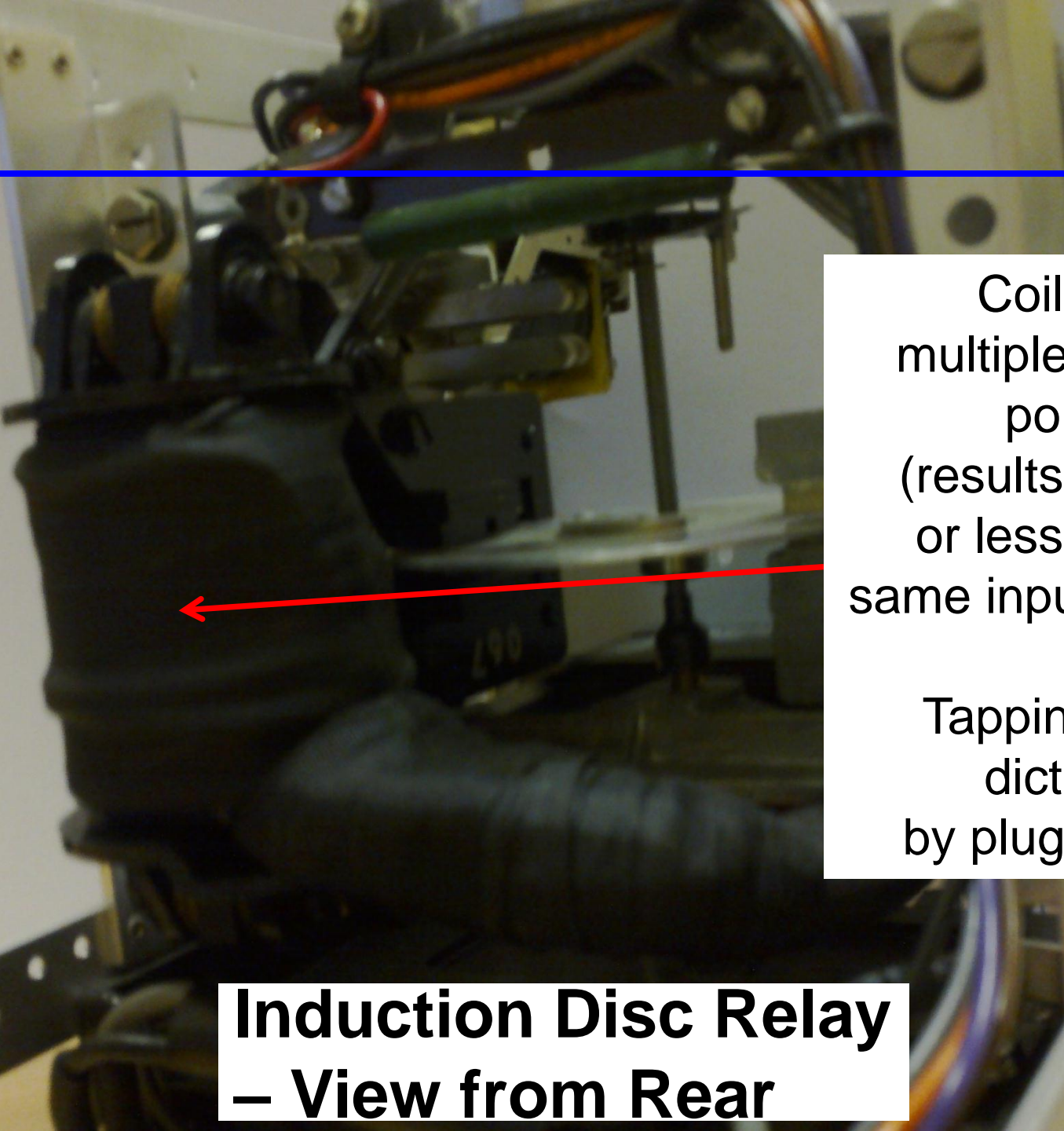

Coil with multiple tapping points (results in more or less flux for same input current).

Tapping used dictated by plug setting.

Induction Disc Relay – View from Rear



Overcurrent Protection - Operation

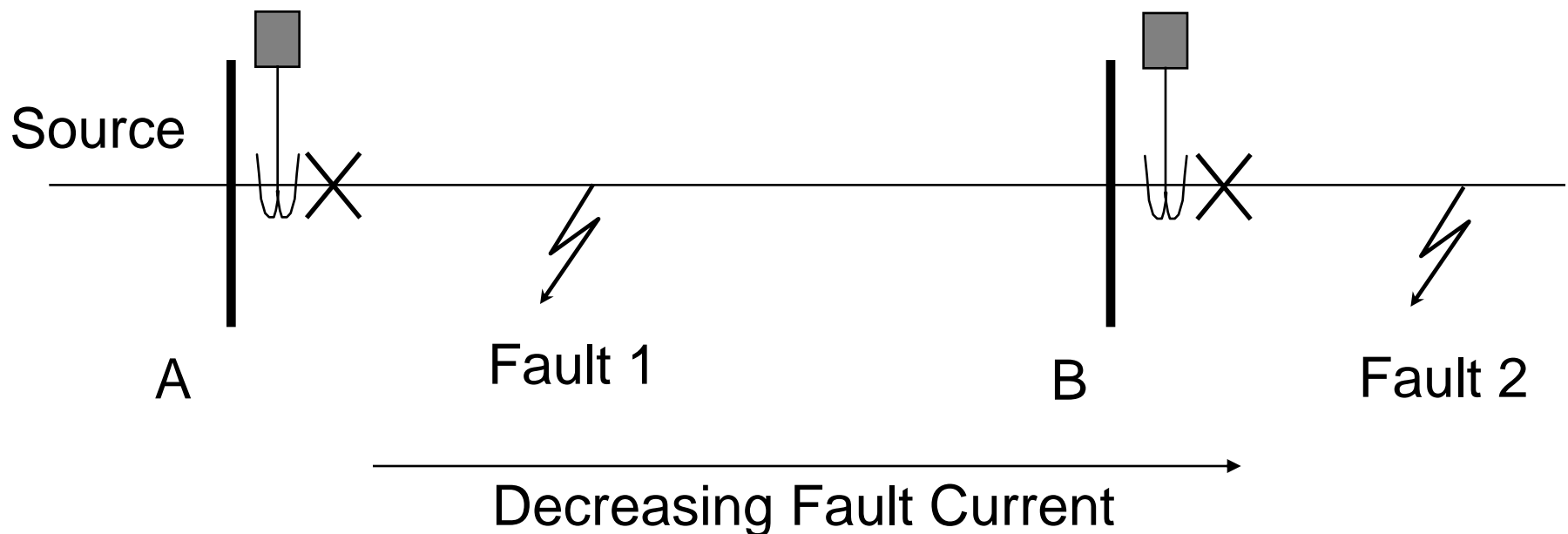
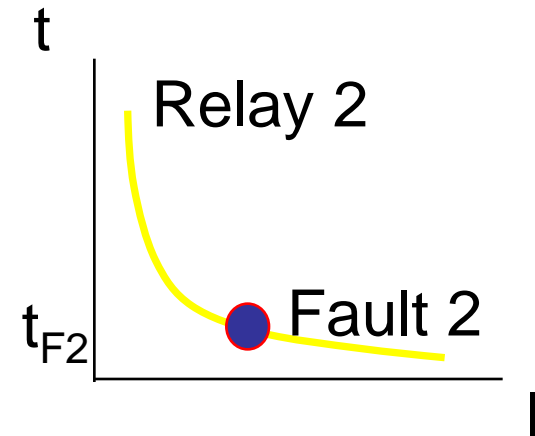
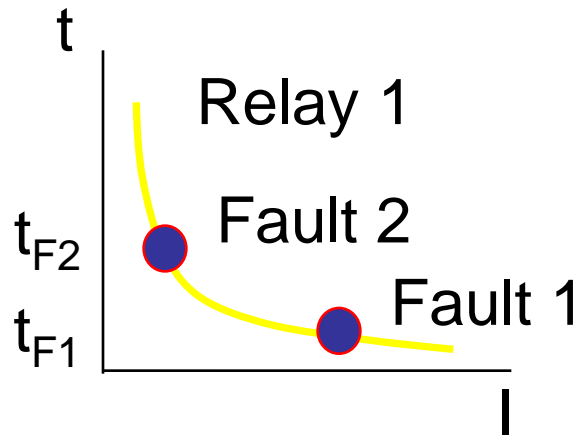

Overcurrent Protection - Operation

Effect on curve "position"
of modifying
Time Multiplier Setting

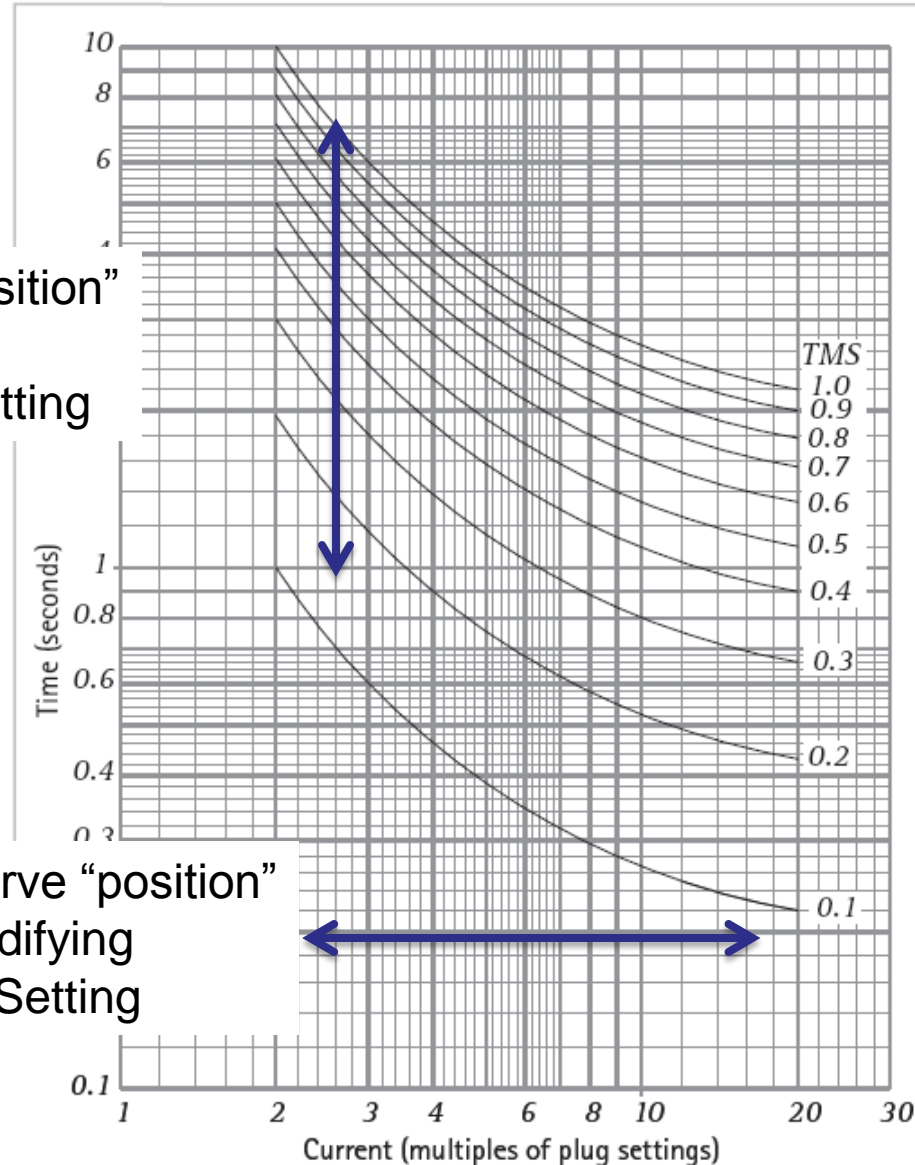

Effect on curve "position"
of modifying
Plug Setting



Relays – Standard Types

Standard Inverse (SI)
Very Inverse (VI)
Extremely Inverse (EI)
Definite Time (DT)

Relay Characteristic	Equation (IEC 60255)
Standard Inverse (SI)	$t = TMS \times \frac{0.14}{I_r^{0.02} - 1}$
Very Inverse (VI)	$t = TMS \times \frac{13.5}{I_r - 1}$
Extremely Inverse (EI)	$t = TMS \times \frac{80}{I_r^2 - 1}$
Long time standard earth fault	$t = TMS \times \frac{120}{I_r - 1}$

(a): Relay characteristics to IEC 60255



Induction disc relay operation

Video showing induction disc relay operation (1:25), marginal operation, or “creep” just before 2 minutes:

<http://www.youtube.com/watch?v=TgzkA3fo-D8&feature=related>

Video that describes magnetic fields, induced eddy currents and forces:

<http://www.youtube.com/watch?v=kU6NSh7hr7Q>



Setting of overcurrent relays

- Alternative methods exist
- One method:
 - Start at furthest downstream relay
 - Progress upstream
 - Each relay is set with the objective of providing backup to next downstream relay with a time delay
 - Important to ensure that upstream relays will not begin to operate before downstream relays for any current



Operation During Fault

Decreasing Fault Current →

Operate
(after a delay)

Operate (quickly)

Don't operate

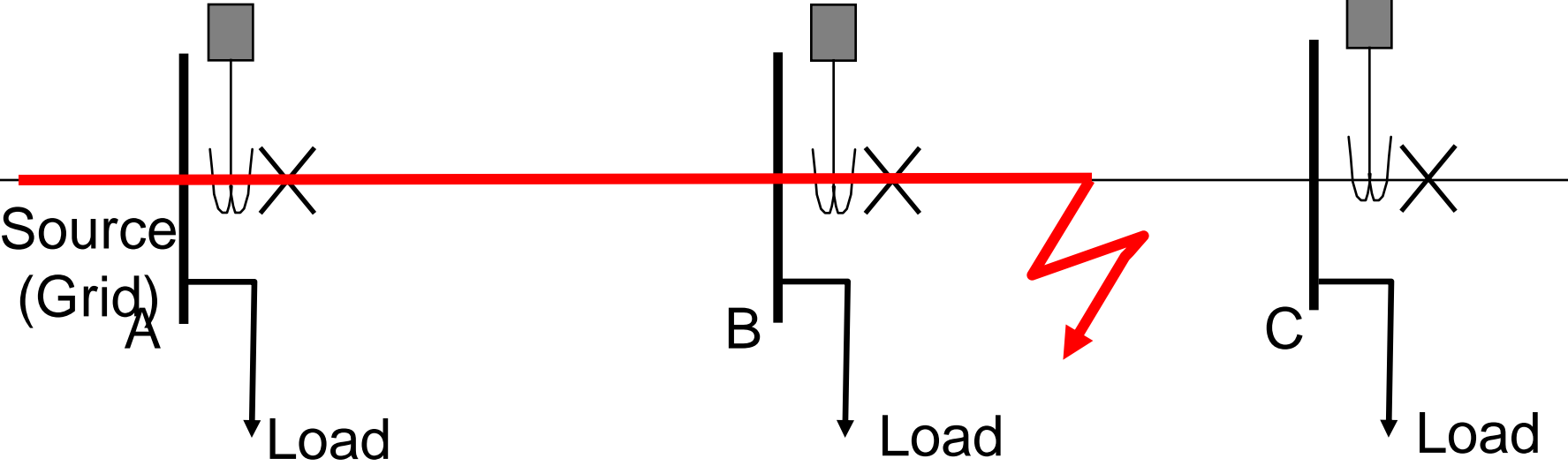

Setting/Grading of Overcurrent Relays

- Summary of procedure – for each relay
 - Calculate (or get from previous study) fault current, CT ratio, relay rating, desired “grading margin”
 - Calculate plug setting (PS) – must result in operating current threshold greater than (130%?) of max load current – check current discrimination with downstream relay(s)
 - Get characteristic operating time (for TSM=1) for fault current
 - Use (or calculate) desired operating time to calculate required TSM
 - Desired operating time is known for furthest downstream relay, or is downstream relay’s operating time for a fault at the downstream location+grading margin)



Overcurrent Protection – Practical Considerations

- Maximum/minimum fault levels
- Motor starting
- Embedded generation
- Meshed networks
- Instantaneous/delayed operation



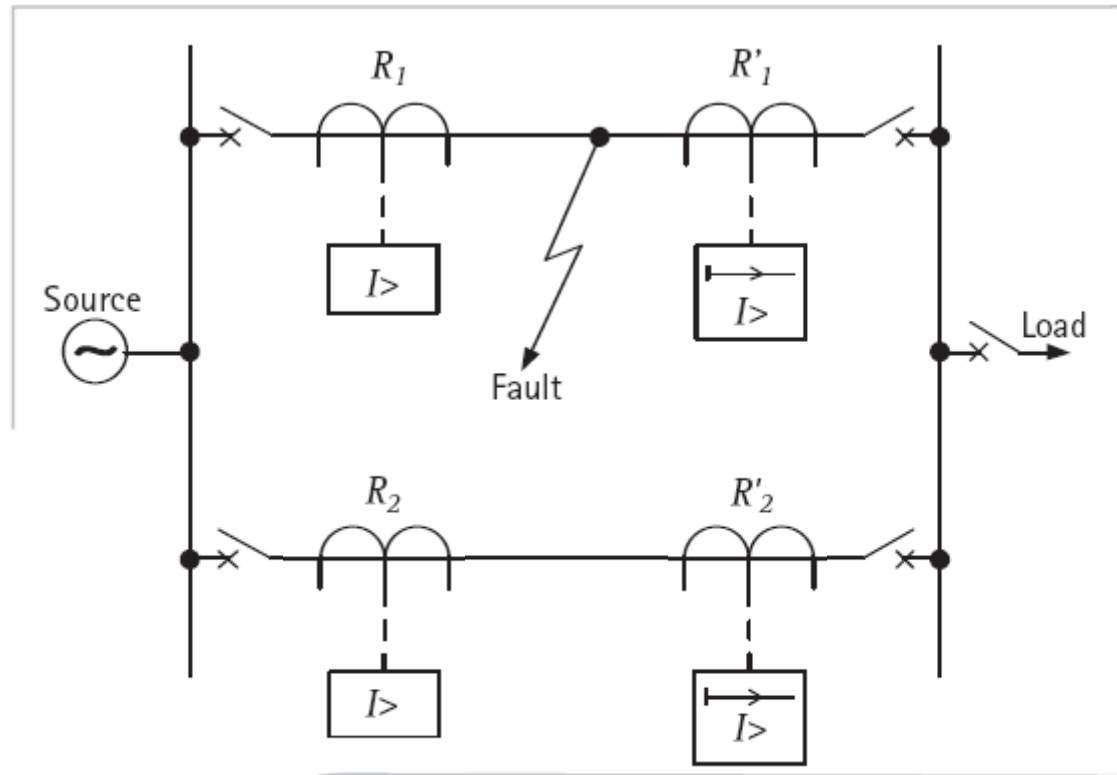

Figure 9.13: Directional relays applied to parallel feeders

Use of directional relays
to provide correct protection
operation on parallel feeders

From NPAG: - chapter 9

www.deadsmall/2VA

Use of overcurrent
relays
for protection of ring
mains

From NPAG: - chapter 9
www.deadsmall/2VA

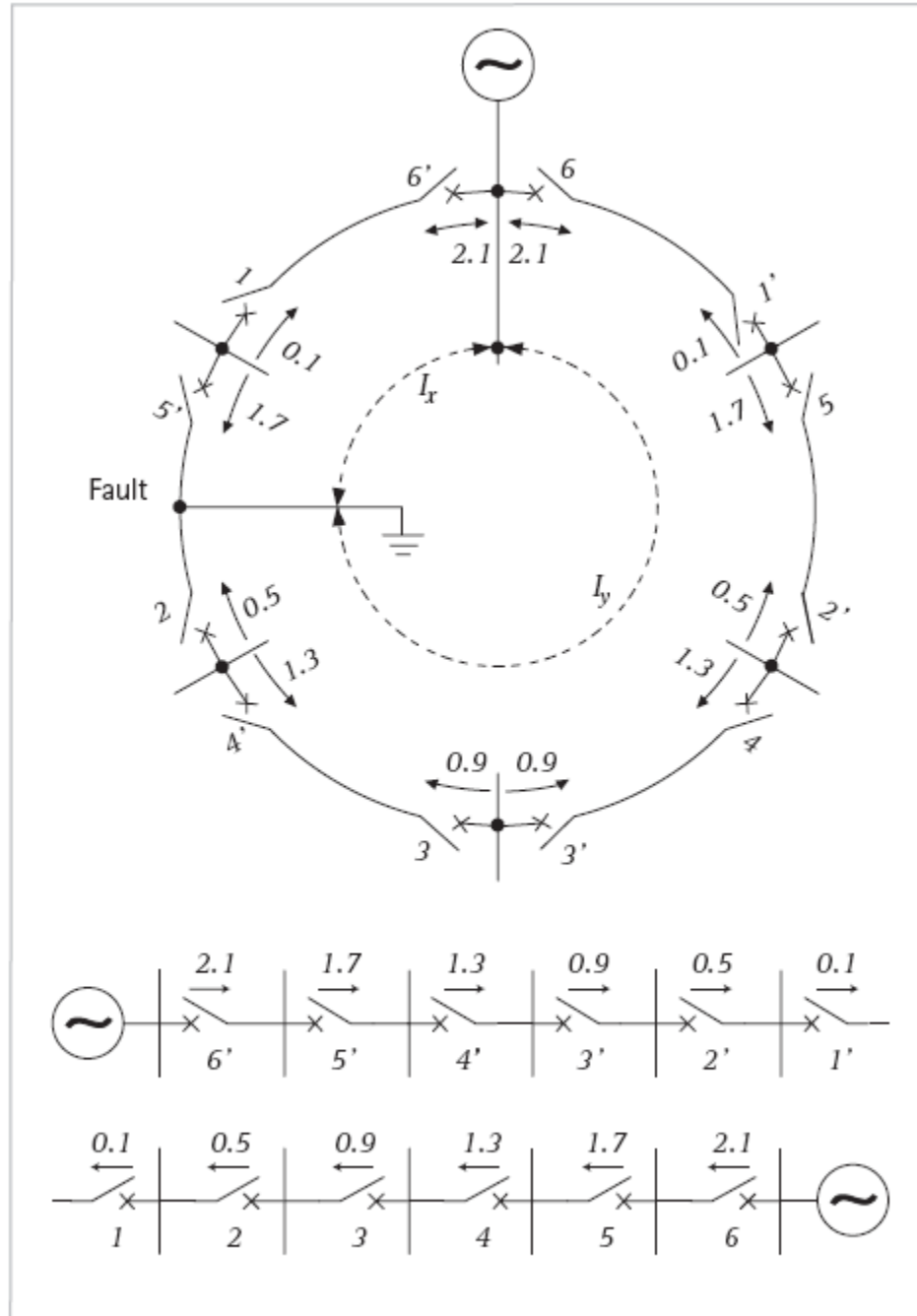
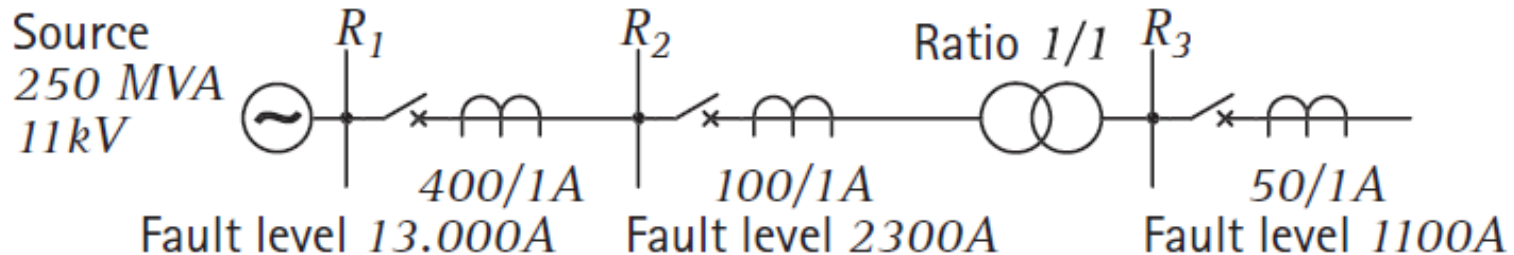
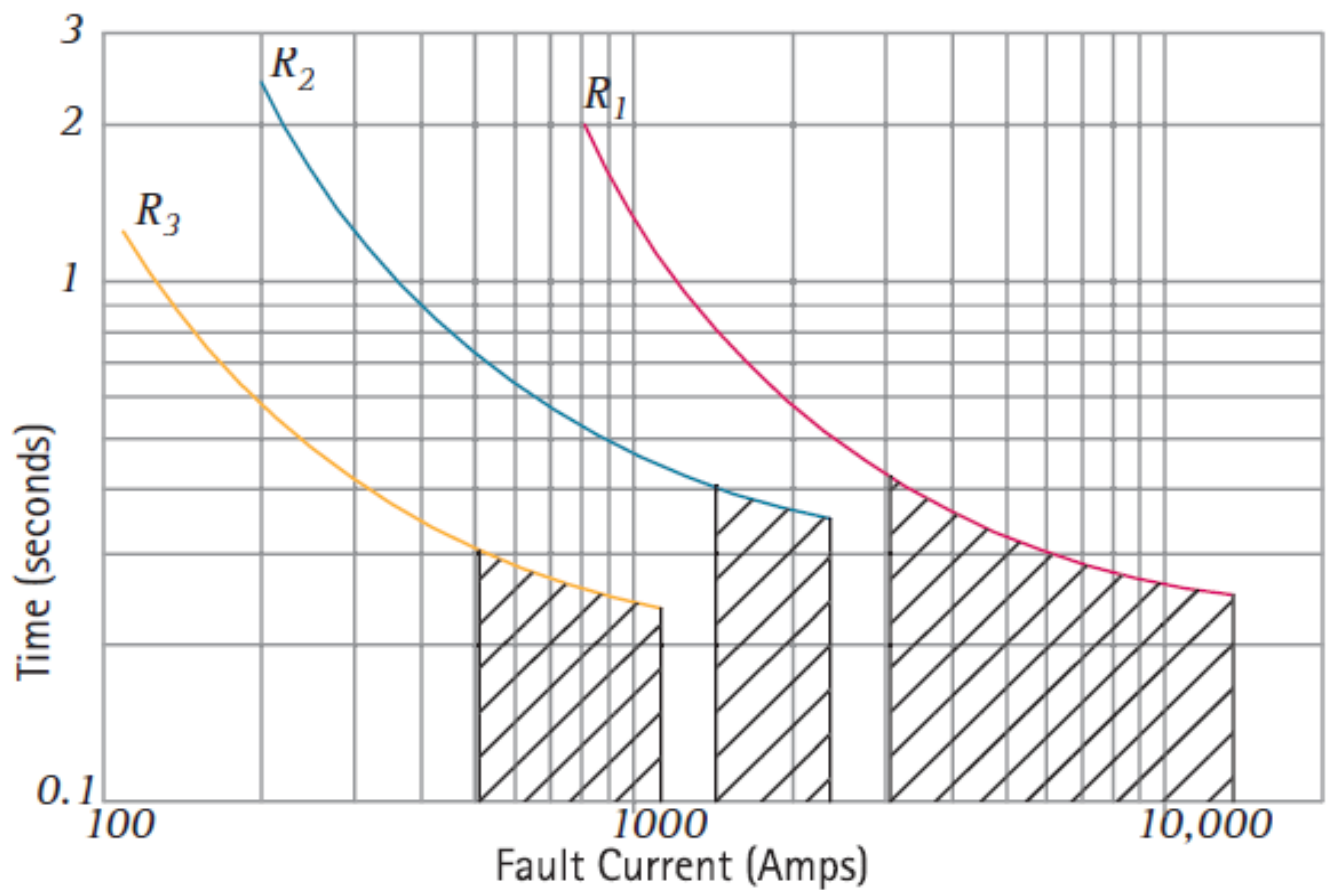

Figure 9.14: Grading of ring mains

**Grading
example with
instantaneous
& inverse
relays (1A)**

**From Areva
NPAG**



PS(%)

I.D.M.T. Relay settings

High set instantaneous relay settings

125% R_1 set at 500A 0.125 TMS

R_1 set 3000A

125% R_2 set at 125A 0.15 TMS

R_2 set at 1400A

125% R_3 set at 62.5A 0.10 TMS

R_3 set at 500A

Protection of Distribution Networks

■ 132/33kV

- Distance, differential (some), overcurrent

■ 11kV/415V

- Overcurrent, reclosers, sectionalisers, fuses, RCDs
- Remember, majority of faults transient – fuses should only operate if fault is permanent
- Typically, faults are isolated very quickly by reclosers, multiple reclose attempts are attempted, and if fault is permanent and downstream of fuses, fuses ultimately melt while system is in reclosed state
- Reclose is then successful
- If permanent fault between recloser and fuse, then recloser will lock-out after pre-defined number of attempts



Protection of distribution networks

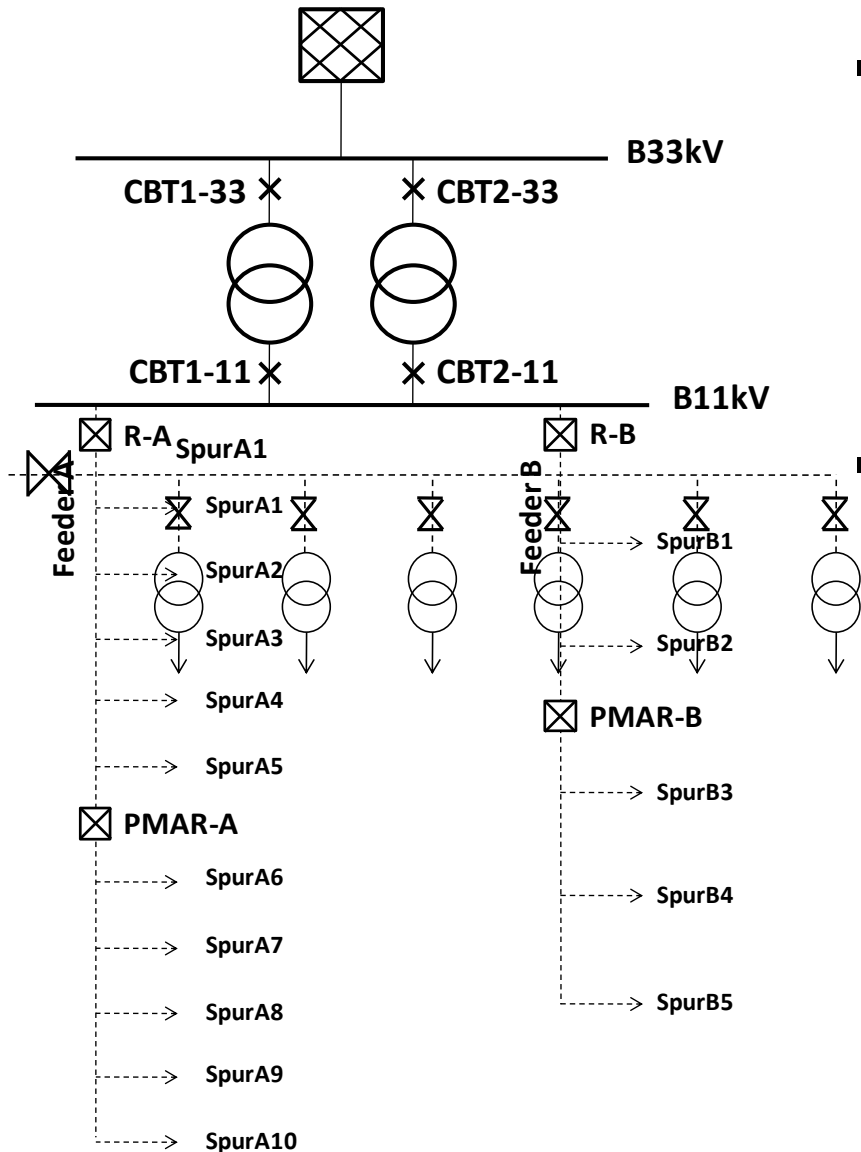

- Distribution network protection is based on overcurrent protection reclosers, sectionalisers and fuses
- In rural distribution networks, >80% of faults are temporary and auto reclose schemes are adopted.



Protection of Distribution Networks

Gers and Holmes
 "Protection of
 Electricity
 Distribution
 Networks",
 IEE Power &
 Energy Series 47

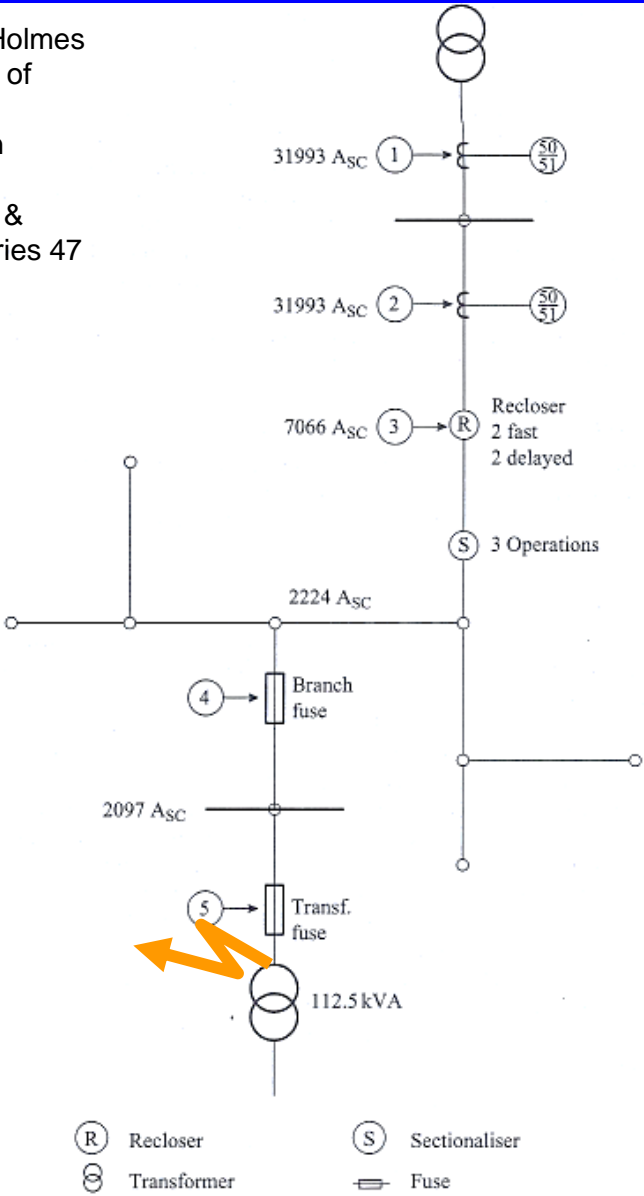

- Transient fault
 - Recloser will successfully reclose
- Permanent fault
 - Recloser will reclose multiple times (with variable delays before re-opening) and fuse will melt before max reclosures attempted
 - Sectionalisers/"smart links" may be used to "save" fuses



Protection of Distribution Networks

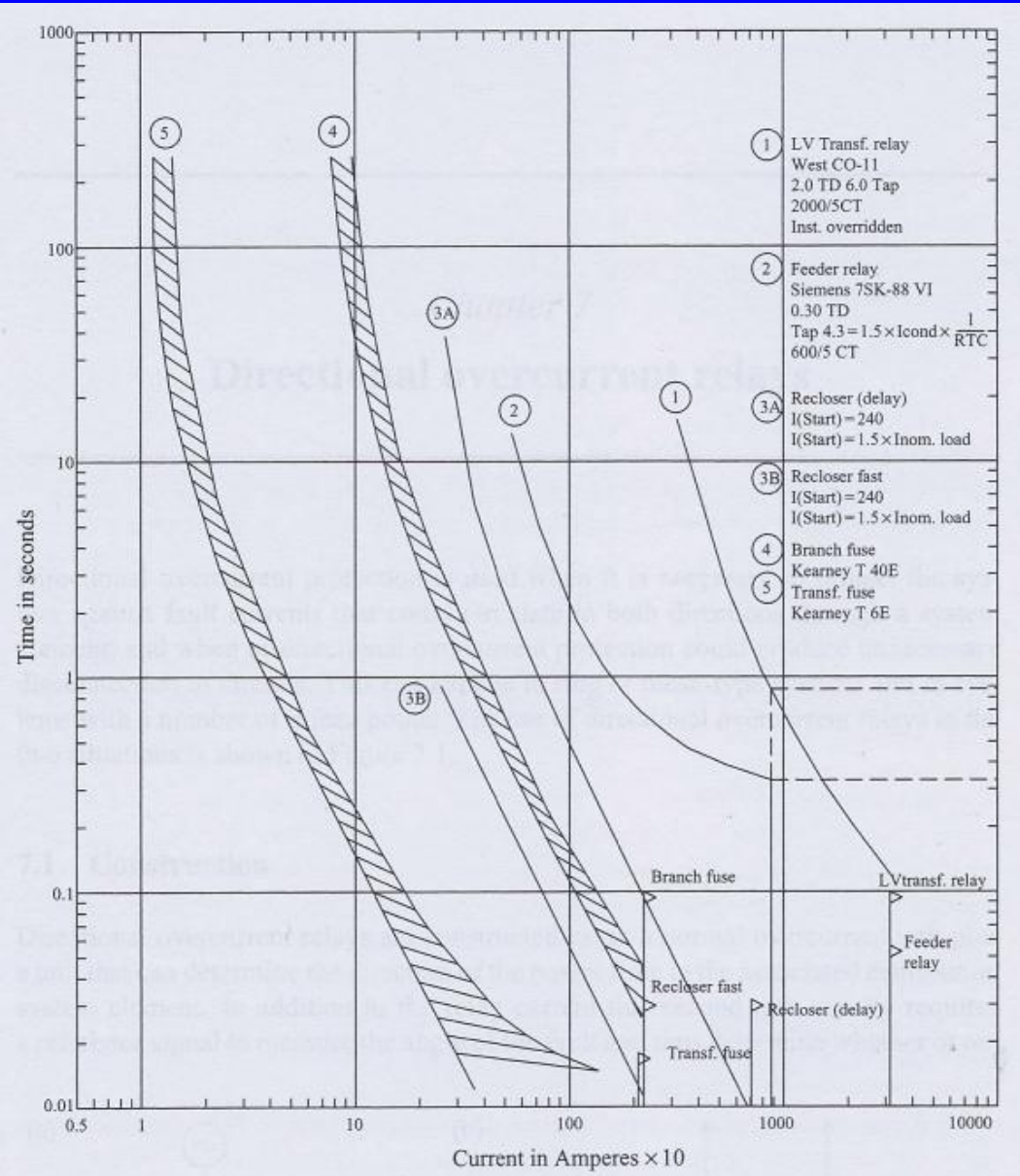

Gers and Holmes
 "Protection of Electricity
 Distribution Networks",
 IEE Power & Energy Series 47

Protection of Distribution Networks

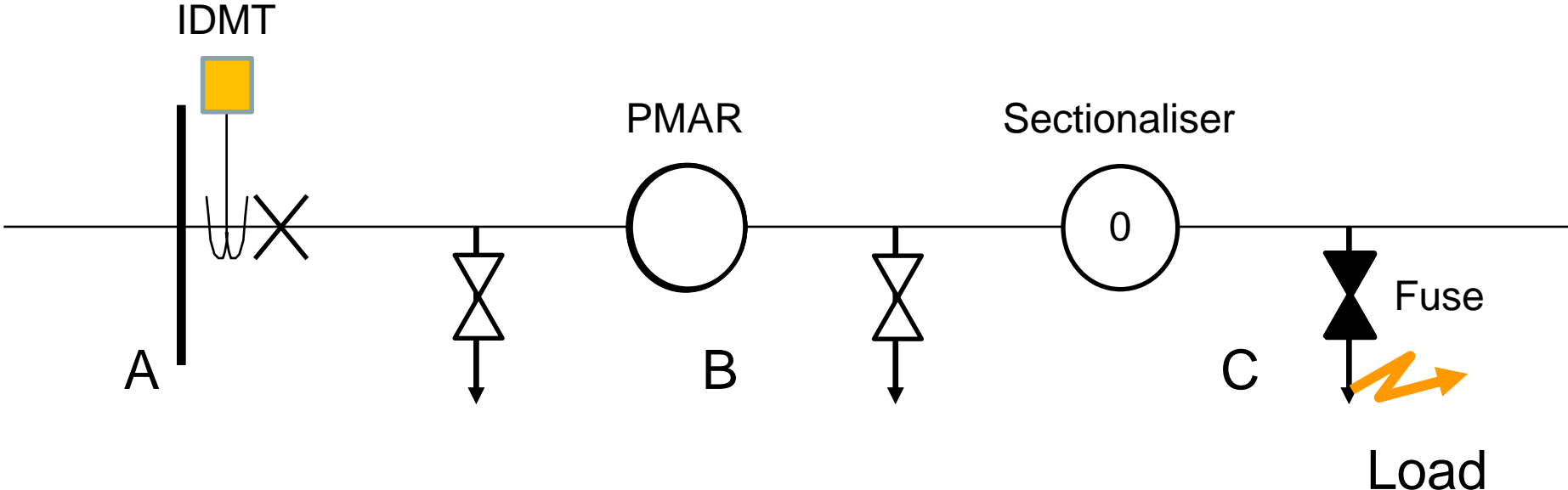

IDMT	Start	Reset	Reset	Start	Reset	Reset	Reset
PMAR	Open	Open	Close	Open	Open	Close	Close
Sectionalizer	Count 1	Count 1	Count 1	Count 2	Count 2	Count 2	Reset
Fuse	1 "shot"	1 "shot"	2 "shots"	2 "shots"	2 "shots"	melt	melted

Fault inception t

Protection of Distribution Networks

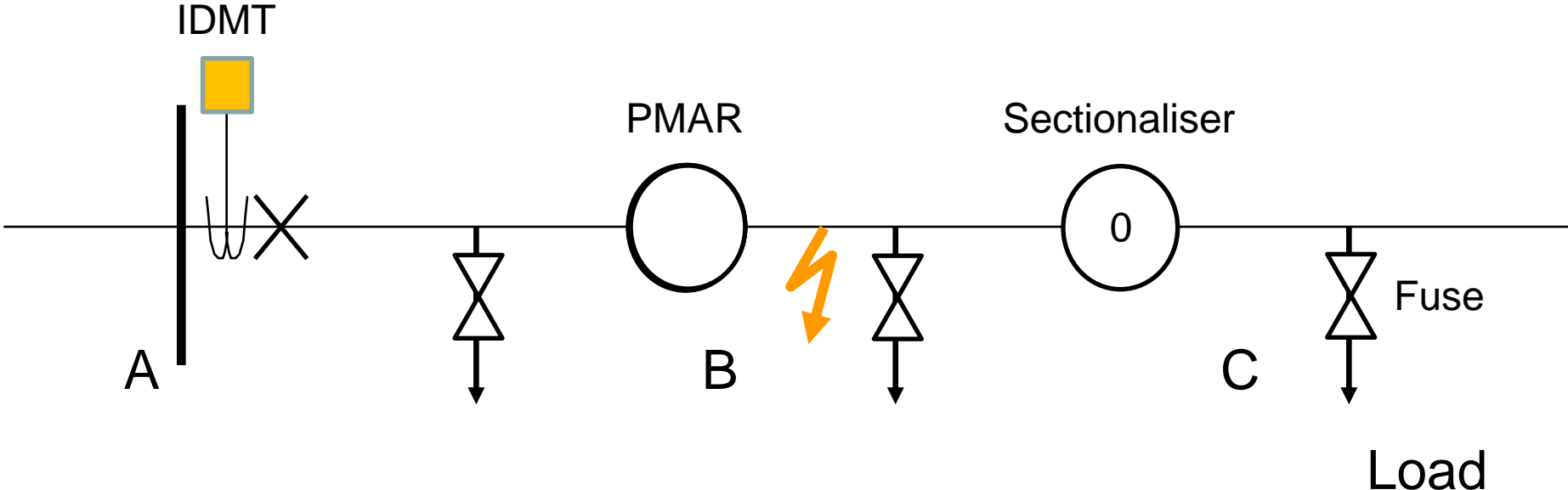

IDMT	Start	Reset	Reset	Reset			
PMAR	Open	Open	Close	Close			
Sectionalizer	Count 1	Count 1	Count 1	Reset			
Fuse							

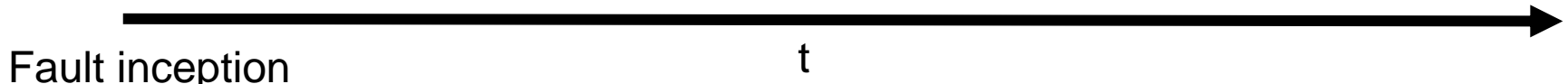

Distribution System Protection: Summary

- Typical distribution network architectures
- Protection basics and requirements (review)
- Brief review of protection philosophies and schemes:
 - Unit/non-unit
 - Differential/distance/overcurrent
 - Reclosers/Sectionalisers/Fuses
- Summary of operation and setting of distribution protection
- Practical considerations

